

User Manual for all Spex Head Supports (product code begins with '1270-')

Revision: Headrest20201104_EN



spex

Head Support
Installation & User Manual

IMPORTANT CONSUMER INFORMATION NOTICE:

This manual contains important instructions that must be passed on to the user of this product. Please do not remove this user manual before delivery to the end user.

SUPPLIER: This manual must be given to the user of this product.

USER/CAREGIVER: Before using this product, read entire manual and save for future reference. Transit Safety section **MUST** be read before cushion is used in a vehicle.

User Name:

Serial Number:

Contents

| | |
|---|----|
| Introduction | 2 |
| Safety Instructions | 3 |
| Weight Capacity | 3 |
| Environment | 3 |
| Compatibility | 4 |
| Warnings | 4 |
| Head Support Contents | 5 |
| Re-issuing to Another User | 5 |
| Disposal & Recycling | 5 |
| Installing Mounting Block | 6 |
| Attaching Pad to Mechanism | 6 |
| Adjusting Stem Height | 6 |
| Adjusting Horizontal, Lateral & Angle Positions | 7 |
| Operating Flip-Away (if fitted) | 7 |
| Adjustable Lateral Wings (if fitted) | 8 |
| Maintenance | 9 |
| Transit Safety – Assembly, Use, Maintenance & Limitations | 10 |
| Transit Safety – Correct Positioning of Belt Restraints | 11 |
| Warnings | 12 |
| Warranty | 15 |

Introduction

The Spex Head Support is a modular and adjustable support for the head. Note: Check all parts are free from shipping damage. Contact Medifab or your supplier for further instructions if needed.

Medifab recommends that a clinician such as an Occupational Therapist or Physiotherapist who is skilled in wheelchair seating and positioning be consulted to determine if the Spex Head Support is appropriate for the user. The intended user of the Spex Head Support is a user with postural support requirements.

Safety Instructions

To avoid injury, read, understand and follow all instructions and warnings in this manual before installing and using the Spex Head Support. There are hazards associated with the use of wheelchairs and adaptive equipment. If you misuse your wheelchair or your Head Support you can be seriously injured. If your Head Support ceases to function as intended, please consult your authorized Spex seating supplier immediately before continuing to use.

Spex Head Support meets the requirements of ISO 7176-16; wheelchairs - resistance to ignition of postural support devices. The cover and foam meet the flammability requirements of California Technical Bulletin 117. In rare cases the fabrics used in this product may cause a skin irritation for people with sensitive skin. If you experience any reddening or itching of the skin consult with your health care professional.

Disclaimer: Medifab takes no responsibility as to the therapeutic effectiveness of our products. Our claims relate to the ability of the products to provide safe and reliable positioning and seating on the equipment onto which they are installed.

Weight Capacity

- Head Support maximum user weight: **400 lbs. (180 kg)**



WARNING

Never exceed the weight capacity of your Head Support or the wheelchair as specified by the wheelchair manufacturer. Never perform exercise weight training that causes the user to exceed the weight capacity of the wheelchair.

Environment

Moisture: Keep your Head Support dry at all times, as contact with water or excess moisture could cause corrosion, degradation to the functionality of your Head Support, or potential failure. If your Head Support becomes damp or wet, thoroughly wipe with a dry cloth as soon as possible. Do not use your Head Support in a showering or pool facility.

Temperature: Your Head Support may not function as intended when used at extreme temperatures. Keep the Head Support away from sources of extreme heat or extreme cold to avoid burns from the metal components.

Dirt: Small particles such as dust, dirt and sand may restrict optimum functionality. Regularly check your Head Support to ensure no build-up occurs around openings and moving parts.

Compatibility

- Spex Head Support can be installed to other wheelchair back supports ensuring that a strong and rigid mounting surface is present to enable effective installation and on-going use.
- Spex Head Supports are tested and certified for the Spex brand and may not be appropriate for installation to other brands of wheelchair seating.
- Spex Head Supports are not to be used in a different manner other than what they have been designed for.
- If Spex Head Support hardware is mounted to another brand of head support pad not manufactured by Medifab/Spex Seating, this configuration is deemed not tested and certified, whereby the prescriber/purchaser takes full responsibility for outcomes.



WARNINGS

RISK OF ACCIDENT, INJURY, PAIN OR DEATH IF WARNINGS ARE NOT HEEDED

Seek assistance if you are uncertain about any of the following points

- 1. Hardware is shipped out disassembled and with brackets attached loosely. It is the installer's responsibility to ensure all hardware is installed correctly and tightened before using the wheelchair.**
- 2. Installation and adjustment of your Spex Head Support must only be performed by**
 - a) An authorized Spex distributor or technician**
 - b) A qualified healthcare professional who has undergone appropriate biomechanical training**
- 3. The Head Support must not be modified or changed as this voids warranty.**
- 4. Only use genuine Spex accessories, components and hardware.**
- 5. Never lift the wheelchair by the Head Support.**
- 6. Never use the Head Support if any hardware is missing, malfunctioning or broken. Seek qualified assistance with any repairs, replacements or adjustments.**
- 7. A poorly fitted Head Support can aggravate posture problems and the overall safety of the user.**
- 8. The user must not put excessive force against the Head Support.**
- 9. Do not attach the Head Support to the back support more than 2" above the top back support attachment points to the wheelchair. If the Head Support is attached too high above the top attachment point of the back support to the wheelchair frame the life of the back support shell will be greatly reduced.**
- 10. Ensure all fasteners are securely tightened before seating the user in the wheelchair seat.**
- 11. The Head Support should be positioned close behind the user's head to reduce the chance of injury from whiplash in the case of an accident.**
- 12. Care must be taken when undertaking a user transfer from the seating system. The user may fall from the wheelchair or injure themselves when supports are removed.**
- 13. Be aware of the pinch points. Ensure all body parts are kept clear during these movements and adjustments.**
- 14. Never use the Head Support without its cover. Care should be exercised near open flame or burning cigarettes. Using the Head Support without its cover increases the risk of flammability and skin damage.**

Head Support Contents

Your Head Support contains the following:

| | Description | Quantity |
|---|-----------------------|----------|
| A | Head Support Pad | 1 |
| B | Swivel Ball | 1 |
| C | Positioning Mechanism | 1 |
| D | Stem | 1 |
| E | Drop Stopper | 1 |
| F | Mounting Block | 1 |
| G | Fasteners | 2 |

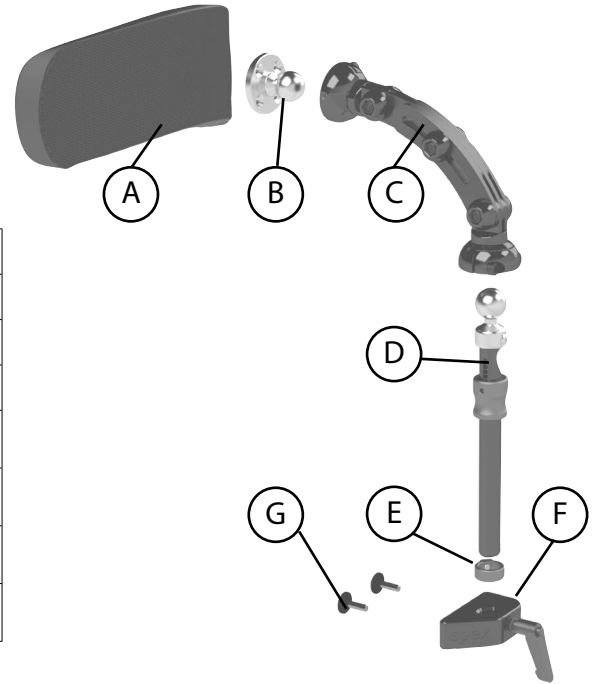

Re-issuing to Another User

Once the user has finished using the Spex Head Support, it must be refurbished and thoroughly cleaned if it is issued to another user. Below are the strict guidelines for refurbishing the Spex Head Support. Medifab takes no responsibility for contamination, cross infection, or damage. Medifab recommends using AHP (Accelerated Hydrogen Peroxide) disinfectant wipes. The disinfection product must be used as per the manufacturer instructions. Medifab takes no responsibility for the effectiveness of the disinfecting process.

| Part | Procedure |
|-------------------------|---|
| Safety check | All components to be checked for signs of stress or cracking. |
| Upholstery covers | Covers must be replaced regardless of condition. |
| Hardware and components | Ensure the mechanism components are in place and in safe working order. If any are missing, they must be ordered. Check for signs of stress or cracking. If any stress/cracks are found the Head support is to be condemned and must be disposed of. Clean the hardware and components with a mild detergent and quality disinfectant ensuring all areas are free from grime. |
| Foam | Foam pad must be replaced regardless of condition. |

Disposal & Recycling

Your Spex Seating System is manufactured using a variety of materials, most of which can be recycled. Once it reaches the end of its life, if you are the legal owner, do not dispose of as ordinary household waste but take your Spex System to an approved recycling or collection point, to dispose of according to local laws and regulations. Separate collection and recycling of the Spex System when disposing ensures protection of the environment and assists with natural resource conservation.

Installing Mounting Block



4mm Hex Key

1. Bolt the mounting block directly to the back support using the M6 x 25mm screws and washers. Use a 4mm hex key to tighten the bolts.

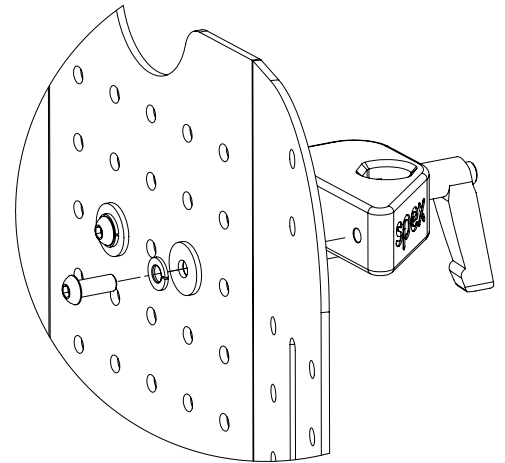

Attaching Pad to Mechanism



5mm Hex Key

1. Loosen both bolts in the top clamp to allow the ball on the headrest pad to insert into the socket.
2. Partly tighten the bolts on the top clamp so the headrest pad can move but is not loose.
3. Position the headrest pad correctly, then securely tighten the bolts using a 5mm hex key.

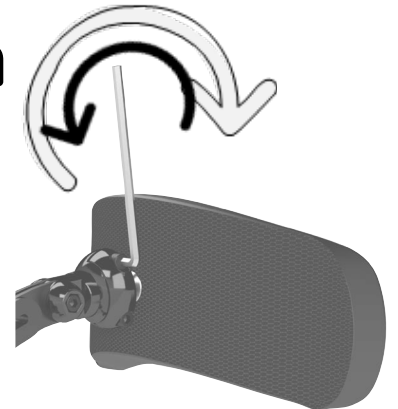

Adjusting Stem Height



3mm Hex Key

1. Loosen the grub screw in the 'Drop Stopper' using a 3mm hex key.
2. Unwind the clamp lever on the mounting block and shift the stem up or down to the new position. Tighten the clamp lever to secure.
3. Tighten the grub screw in the 'Drop Stopper' to fix the stem height when taking the Head Support on and off the wheelchair.

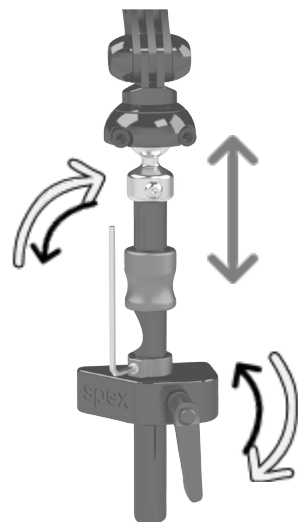

Adjusting Horizontal, Lateral & Angle Positions



5mm Hex Key

- 1.** Check the bolts on the top and bottom clamps are loose and the ball joints are free to rotate.
- 2.** Loosen the bolts in the positioning mechanism using a 5mm hex key.
- 3.** Move the Head Support Pad to the correct position and securely tighten all bolts.

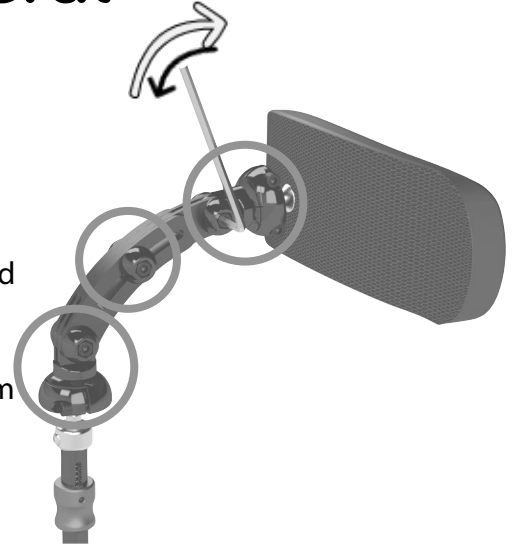

WARNING

Check any links that stick out from the positioning mechanism do not get in the way of the user or wheelchair.

Operating Flip-Away (if fitted)

- 1.** Grip the red collar and pull up.
- 2.** Hold the collar up and carefully lift the head support pad away.

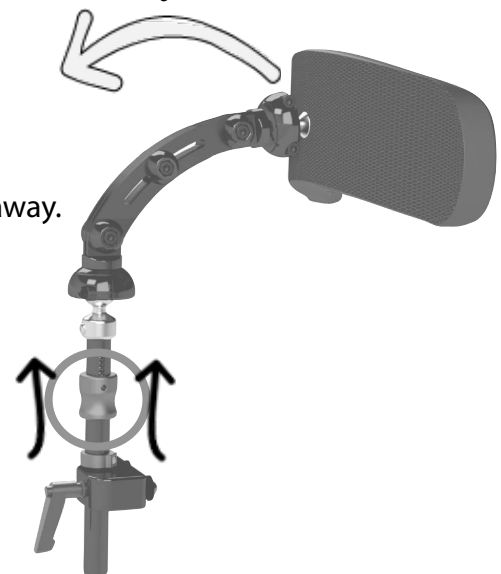

Adjustable Lateral Wings (if fitted)



5mm Hex Key, 10mm Spanner



- 1.** The lateral wings can be positioned at the top or bottom of the centre Head Support pad. To change the lateral pad height, remove the nuts on the back of the centre pad using a 10mm spanner. Remove the lateral wing, unzip the cover and move the fixing stud to the other set of holes. Close the cover, replace the lateral wing and tighten the nuts.
- 2.** Adjust the width between the lateral pads by loosening the 2 nuts on the back of the centre pad with a 10mm spanner. Move the laterals to the correct position and tighten the nuts.
- 3.** Adjust the angle of each lateral pad by loosening the 2 silver screws with a 5mm hex key. Move the laterals to the correct position and tighten the screws.
- 4.** Adjust the forward / back position of each lateral pad by loosening the 2 nuts on the back of the lateral pad with a 10mm spanner. Move the laterals to the correct position and tighten the nuts.

Maintenance

The expected lifetime of the Head Support is 5 years. The Head Support should be checked and cleaned regularly to help extend its life. Medifab recommends that the Head Support is checked every 6 months. If any issues are found stop using the Head Support and contact your Spex Seating supplier immediately.

Maintenance Checklist

- Check that the hardware is working correctly.
- Look for loose bolts or broken components.
- Examine any wear for signs of stress or cracking.
- Tighten any loose fasteners.

Cleaning Checklist

Hardware

- Wipe clean with mild detergent and water.
- Use disinfectant wipes. Medifab recommends using AHP (Accelerated Hydrogen Peroxide) disinfectant wipes. The disinfection product must be used as per the manufacturer instructions. Medifab takes no responsibility for the effectiveness of the disinfecting process.
- Dry thoroughly after wiping.

Cover

- Remove the cover and turn inside out.
- Machine wash in warm water (40° C / 104° F)
- Drip or tumble dry on low heat.
- Do not iron. Do not dry clean. Do not bleach.
- If chemical cleaners are used, rinse cover with water to remove all chemical residue and dry completely before use.
- Check the cover for tears and excessive wear and replace if ripped, torn or broken.

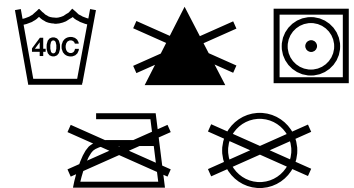

If you have any questions about cleaning procedures, please contact your authorized Spex Seating dealer.

Transit Safety

The Spex Seating System has been successfully crash tested and complies with RESNA WC-4:2012, Section 20 (WC20). The Spex Seating System meets the requirements of ISO 16840-4:2009 and is suitable for use as a motor vehicle seat when used with an appropriate wheelchair base. Please follow all installation, use and maintenance instructions within this manual as well as the following transit instructions. If feasible, the wheelchair user should transfer to the vehicle seat and use the vehicle-installed occupant restraint systems.

Spex Seating System has been designed to accommodate the proper use of vehicle-anchored belt restraints. Spex achieved a rating of Excellent (16 out of 16), for ease of properly positioning a belt restraint, and the degree to which proper belt restraint can be achieved, based on the methods of Annex D. The following items of the Spex Seating System have been tested and are suitable for use in a motor vehicle:

- Full Height Back Support Models
- Grid-Base Seat Pan
- Cushion Models
- Arm and Thigh Supports
- Trunk Lateral Supports
- Head Supports

Note: Back supports that are lower than the user's shoulder height are not certified and not recommended for transport in a vehicle. Eg. Vigour Lo and Vigour Mid back supports.

Assembly, Use, Maintenance & Limitations

- Adjustments to the set-up of the wheelchair must only be carried out by a qualified therapist, professional, or seating technician. Custom contoured/bespoke systems may require a qualified professional to configure and install the seating system.
- After carrying out any adjustments ensure all bolts, screws and nuts are securely fastened again to ensure safety when travelling in a vehicle.
- Ensure the top and bottom mounts of the backrest and the front and rear mounts of the seat pan are installed as far apart from each other as possible to give a stronger 4-point attachment to the wheelchair frame. Ensure the quick release latches are engaged.
- Do not use the Spex Seating System as a vehicle seat if seating components which have not been successfully crash tested are used anywhere on the seating system. Spex seating is designed and certified using only Spex components. Medifab is not liable in the event where other manufactured seating systems are used in conjunction with Spex seating.
- At regular intervals check that all the fastenings on the Spex Seating System have not become loose during day to day use and re-tighten if necessary.
- Ensure the swing-away laterals are in their locked position before using the seat as a vehicle seat in a motor vehicle.



WARNING

Transit Safety

Correct Positioning of Belt Restraints

When using the Spex Seating System as a vehicle seat, both a pelvic-belt restraint and shoulder-belt restraint must always be used. To correctly position the belt restraints on the wheelchair occupant, the following must be ensured:

- The pelvic-belt restraint should be worn low across the front of the pelvis near the junctions of the pelvis and thighs.
- The angle of the pelvic-belt restraint should be between 30° to 75° relative to the horizontal and, ideally, between 45° to 75° to the horizontal (as shown in Figure 2).
- The belt-restraint buckle of three-point belt restraints should be placed in contact with the occupant's body and away from wheelchair components.
- The junction of the shoulder-belt and pelvic-belt of three-point-belt restraints should be located near the hip opposite the shoulder over which the diagonal belt crosses and not near the midline of the occupant.
- Belt restraints should not be routed outside of the wheelchair wheels or over the wheelchair armrests, and should not be held away from the body by wheelchair components or parts.
- Upper torso belt restraints should fit directly over, and in contact with, the middle of the shoulder.
- Belt restraints should be adjusted to fit as snugly as possible, consistent with user comfort.
- Belt restraints should not be worn twisted in a manner that reduces the area of contact of the belt webbing with the occupant.



Figure 1

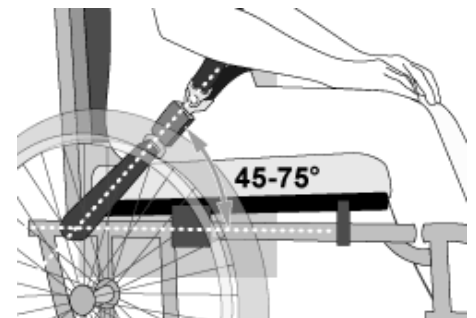

Figure 2



Figure 3a - Improper positioning of pelvic-belt restraints over wheelchair supports.

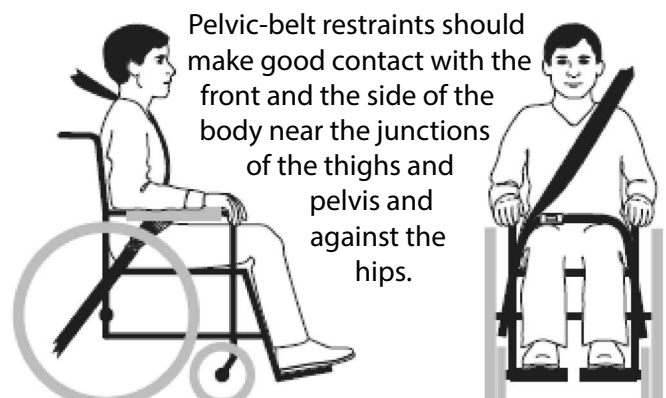

Figure 3b - Proper routing and positioning of belt restraints on the wheelchair occupant.

**WARNING**

- 1. The distance between the top of the user's shoulder and the top of the back should not exceed 6.5" (16.5 cm).**
- 2. The Spex Seating System must only be used with wheelchair bases that are tested as part of a wheelchair system that conforms to performance requirements of ISO 7176-19 and RESNA WC-4:2012, Section 19.**
- 3. The Spex Seating System should only be used on wheelchair frames that provide four securement points and pelvic-belt anchor points that conform to the requirements of RESNA WC-4: 2012, Section 19.**
- 4. The wheelchair must be labelled as appropriate for use as a seat in a motor vehicle, dynamically tested to the performance requirements of ISO 7176-19 and installed, used and maintained according to the manufacturer's instructions.**
- 5. The Spex Seating System must only be used as indicated in this user manual.**
- 6. Both pelvic and shoulder-belt restraints as a part of a complete Wheelchair Tie down and Occupant Restraint System (WTORS) which meets ISO 10542-1 shall be used to achieve effective occupant restraint and optimum protection in a vehicle impact; the belt restraints should be compatible with the specific wheelchair, and fitted to the user in accordance with WTORS manufacturer's instructions.**
- 7. Back supports with adjustable recline angles should not be tilted back more than 30° beyond the vertical during travel in vehicles unless necessary for the medical and postural needs of the occupant.**
- 8. If the back support must be adjusted to an angle that is greater than 30° beyond the vertical during travel, the upper shoulder-belt anchor point should be adjusted rearward to maintain belt contact with the wheelchair occupant's shoulder and chest.**

**WARNING**

9. The Spex Seating System must only be used for forward-facing seating in motor vehicles.
10. In order to reduce the potential of injury to vehicle occupants, wheelchair-mounted rigid trays not specifically intended for use during travel in motor vehicles must be:
 - a. Removed and secured separately in the vehicle or
 - b. Secured to the wheelchair so they will not break free in a crash and
 - Be positioned with a gap of at least 3" (75 mm) between the back edge of the tray and the wheelchair occupant's abdomen and/or chest so as not to interfere with the proper belt-restraint use, and
 - Have energy absorbing padding placed between the back edge of the tray and the wheelchair occupant.
11. Alterations or substitutions must not be made to the seating system structure, parts or components, without first consulting Medifab.
12. The use of a postural pelvic belt attached to the wheelchair base or seat frame is encouraged during travel, but these belts should be positioned so that they don't interfere with the proper positioning of crashworthy belt restraints, and they should not be relied on for occupant protection in crash situations unless the postural belt has been designed to comply with, and perform to the requirements of WC19.
13. Postural support devices that are not labelled as conforming to ISO 16840-4 may be used when in a vehicle, but should not be relied on for occupant restraint.



14. Both pelvic-belt and shoulder-belt restraints that comply with WC18 and/or WC19 should be used to limit occupant movement in a crash and reduce the likelihood of occupant ejection from the vehicle and/or injurious contact of the occupant with the vehicle interior.
15. Belt restraints should be positioned on the wheelchair occupant in accordance with WTORS manufacturer's instructions.
16. Backrest mounting hardware must be installed correctly. Refer to the appropriate section for correct backrest hardware mounting instructions.
17. If the wheelchair is being transported while occupied, the wheelchair must still be secured to the WTORS.
18. Children whose mass is less than 48.5 lbs. (22 kg) should be transferred from their seating system into appropriate child restraint systems intended for use in motor vehicles.
19. Sufficient forward and rearward clear space should be provided around the wheelchair occupant. Forward clear-space zone (FCZ) needs to be larger when a shoulder-belt restraint is not used.

FAILURE TO HEED THESE WARNINGS COULD CAUSE SEVERE INJURY TO THE WHEELCHAIR USER OR OTHERS.

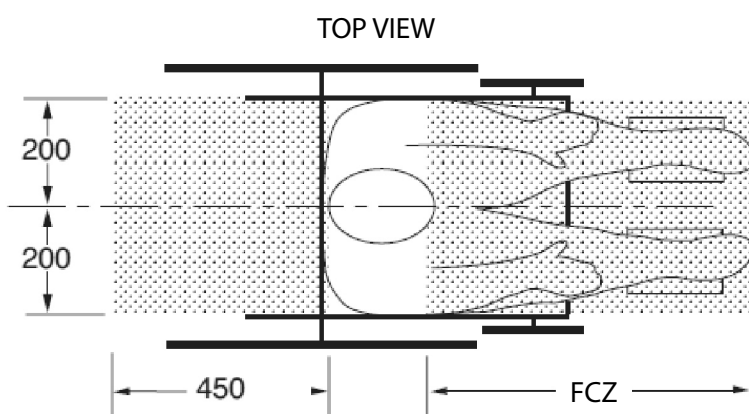

NOTES: The rear clear zone is measured from the rearmost point on an occupant's head. The front clear zone is measured from the frontmost point on an occupant's head.

Seated head height (HHT) ranges from about 47" (1200 mm) for a small adult female to about 61" (1550 mm) for a tall adult male.

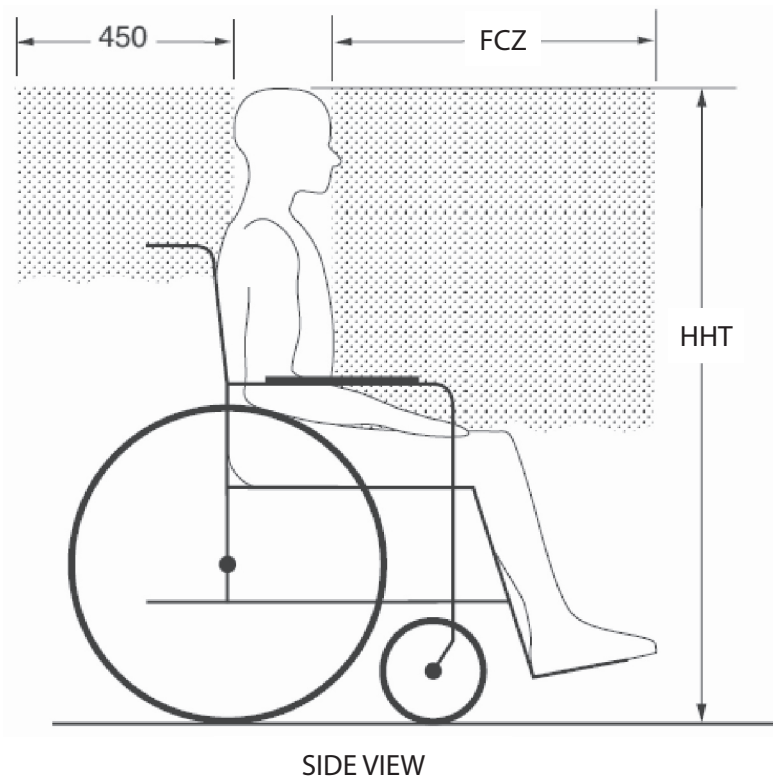

FCZ = 25.5" (650 mm) with upper torso restraint
 = 37" (950 mm) with only pelvic restraint

NOTE: It is strongly recommended that both pelvic and upper torso belts be used.

Recommended forward and rearward clear zones for wheelchair seated occupants.
 (Note: the FCZ may not be achievable for wheelchair seated drivers).

Warranty

Each Spex Head Support is carefully inspected to provide peak performance and is guaranteed to be free from defects in materials and workmanship for a period of 24 months from the date of purchase, provided normal use. Should a defect in materials or workmanship occur within 24 months from the original date of purchase, Medifab will, at its option, repair or replace it without charge. This warranty does not apply to general wear and use, including punctures, tears or burns, nor to the removable cover.

Claims and repairs should be processed through the nearest authorized Spex supplier. Except for express warranties made herein, all other warranties, including implied warranties of merchantability and warranties of fitness for a particular purpose are excluded. There are no warranties which extend beyond the description on the face hereof. Remedies for breach of express warranties herein are limited to repair or replacement of the goods. In no event shall damages for breach of any warranty include any consequential damages or exceed the cost of non-conforming goods sold.

The serial number of your Head Support can be located by unzipping the Head Support cover.



237 Romina Drive, Unit 3
Concord, ON
Canada L4K 4V3



© 2021 Sunrise Medical Canada Inc.
Phone: (800) 263-3390
Fax: (800) 561-5834
cscanada@sunmed.com
www.sunrisemedical.ca

773901-CAN, Rev. A