

# JAY<sup>®</sup>

## J3<sup>®</sup> PLUS Back

### JAY<sup>®</sup> J3<sup>®</sup> PLUS Back

**IMPORTANT CONSUMER INFORMATION**

**NOTICE:** *This manual contains important instructions that must be passed on to the user of this product. Please do not remove this manual before delivery to the end user.*

**SUPPLIER:** *This manual must be given to the user of this product.*

**USER:** *Before using this product, read this entire manual and save for future reference.*

**WARRANTY REGISTRATION:** Visit [www.SunriseMedical.com](http://www.SunriseMedical.com) to register this product.

Owner's Manual

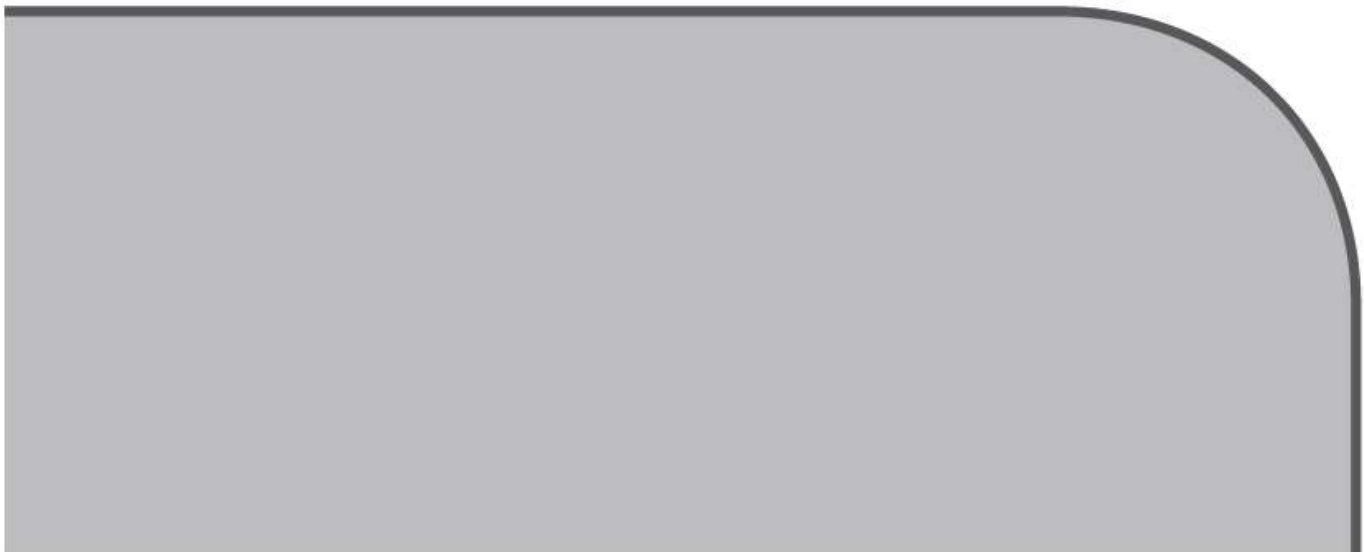

**IMPORTANT CONSUMER INFORMATION**

**NOTICE:** This manual contains important instructions that must be passed on to the user of this product. Please do not remove this manual before delivery to the end user.

**SUPPLIER:** This manual must be given to the user of this product.

**USER:** Before using this product, read this entire manual and save for future reference.

**WARRANTY REGISTRATION:** Visit [www.SunriseMedical.com](http://www.SunriseMedical.com) to register this product.



# I. TABLE OF CONTENTS

INTRODUCTION ..... 4  
 GENERAL WARNINGS ..... 5  
 USE AND MAINTENANCE ..... 7  
 FITTING THE BACK TO THE CHAIR..... 9  
 INSTALLATION & ADJUSTMENT ..... 10  
 ACCESSORIES ..... 14  
 WARRANTY ..... 15

## SUNRISE MEDICAL LISTENS

Thank you for choosing the J3® Plus Back Support System. We want to hear your questions or comments about this manual, the safety and reliability of your product, and the service you receive from your Sunrise Medical authorized dealer. Please feel free to write or call us at the address and telephone number below:

### SUNRISE MEDICAL (US) LLC

Customer Service Department  
 12002 Volunteer Blvd.  
 Mount Juliet, TN 37122, USA  
 (800) 333-4000

Be sure to register your product and let us know if you change your address. This will allow us to keep you up to date with information about safety, new products, and options to increase your use and enjoyment of this product.

You can register your product at:  
[www.SunriseMedical.com/register](http://www.SunriseMedical.com/register)

### FOR ANSWERS TO YOUR QUESTIONS

Your Sunrise Medical authorized dealer knows your product best, and can answer most of your questions about product safety, use, and maintenance.

For future reference, please fill in the following:

Dealer: \_\_\_\_\_

Address: \_\_\_\_\_

Telephone: \_\_\_\_\_

Serial #: \_\_\_\_\_ Date/Purchased: \_\_\_\_\_

### ADDITIONAL INFORMATION YOU SHOULD KNOW

No component of this product was made with Natural Rubber Latex.



### DISPOSAL AND RECYCLING INFORMATION

When this product reaches the end of its life, please take it to an approved collection or recycling point designated by your local or state government. This product is manufactured using a variety of materials. Your product should not be disposed of as ordinary household waste. You should dispose of your product properly, according to local laws and regulations. Most materials that are used in the construction of this product are fully recyclable. The separate collection and recycling of your product at the time of disposal will help conserve natural resources and ensure that it is disposed in a manner that protects the environment.

Ensure you are the legal owner of the product prior to arranging for the product disposal in accordance with the above recommendations.

Sunrise Medical recommends that a clinician such as a doctor or therapist experienced in seating and positioning be consulted to determine if a J3 Plus Back is appropriate. Backs should only be installed by an Sunrise Medical Authorized Dealer.

**JAY® J3® PLUS BACK**

The JAY J3 Plus Back is designed to provide the important benefits of a proper back support for heavy duty end users.

Maximum user weight is 500 lbs. (227 kg.)

**JAY J3 Plus Back Hardware**

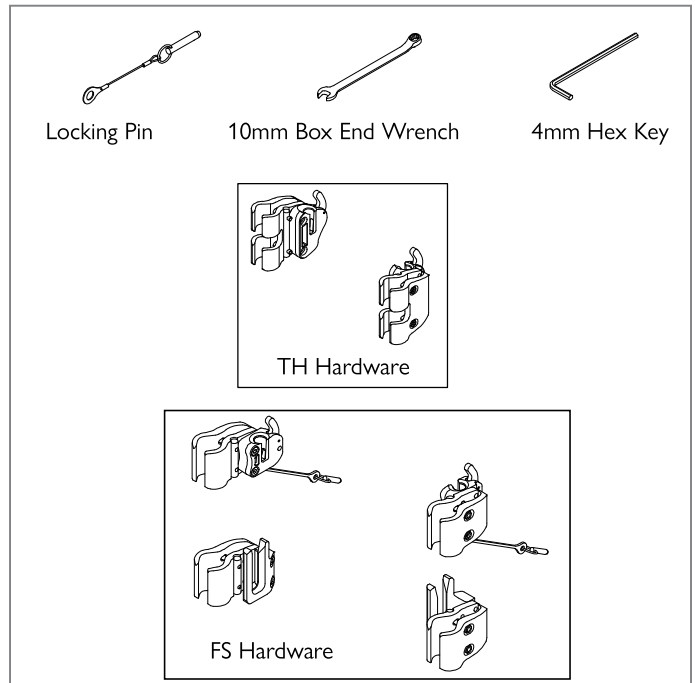

### III. GENERAL WARNINGS

#### A. CENTER OF GRAVITY

##### **WARNING**

Installing a back support on a wheelchair may effect the center of gravity of the wheelchair, and may cause the wheelchair to tip backwards potentially resulting in injury to the user.

#### B. ANTI-TIPS

##### **WARNING**

Anti-tip tubes can help keep your chair from tipping over backward in normal conditions.

1. Sunrise recommends the use of anti-tip tubes.
2. ALWAYS assess the need for anti-tips or amputee axle adapter brackets that could be added to the wheelchair to help increase the stability of the wheelchair and seating system.

If you fail to heed these warnings, damage to your chair, a fall, tip-over, or loss of control may occur and cause severe injury to the rider or others.

#### C. PUSHING OR LIFTING

##### **WARNING**

Do not use the J3 Plus Back to move or push the wheelchair.

1. Do not use the J3 Plus Back handle to lift the wheelchair. It is intended only for back removal.
2. Improper use of the back by pushing or pulling may cause the back to unexpectedly detach from the wheelchair.

If you fail to heed these warnings, damage to your chair, a fall, tip-over, or loss of control may occur and cause severe injury to the rider or others.

#### D. COMPATIBILITY

The J3 Plus Back is designed to be compatible with most wheelchairs with the following exception:

1. Wheelchairs that are angle adjustable with recline or tilt, and result in a back angle greater than 60° from the vertical.

J3 Plus Back used with these types of wheelchairs may cause the back to accidentally disconnect from the wheelchair. This could result in a fall or potential injury of the rider and/or caregiver.

#### E. J3 PLUS BACK TRANSIT SAFETY 1 2

##### **WARNING**

The J3 Plus Back has been dynamically tested for use in a motor vehicle. This system conforms with ANSI/RESNA WC-20. If the J3 Plus Back is to be used in a transit situation, it must be mounted to a wheelchair that conforms to the performance requirements of ANSI/ RESNA WC-19. For rider safety, please follow all installation, use, and maintenance instructions within this manual as well as the transit instructions below.

1. If possible and feasible, the rider should transfer to the Original Equipment Manufacturer vehicle seat and use the vehicle restraints.
2. The distance between the top of the user's shoulder and the top of the back should not exceed 6.5-in (16.5 cm).
3. The wheelchair must be labeled as appropriate for use as a seat in a motor vehicle, dynamically tested to the performance requirements of ISO Standard 7176-19 and installed, used, and maintained according to the manufacturer's instructions.
4. If the original wheelchair seat was replaced, the new seat must be approved for wheelchair transit, installed and used as indicated in the manufacturer's instructions.
5. The Wheelchair Tiedown and Occupant Restraint System (WTORS) should be compatible with the specific wheelchair, used as indicated in the manufacturer's instructions, and should comply with the performance requirements of ISO Standard 10542.
6. The wheelchair must be forward facing during transport.
7. In order to reduce the potential of injury to vehicle occupants, wheelchair-mounted accessories such as trays and respiratory equipment should be removed and secured separately.
8. This product is intended for use by adults up to 500 lbs (227 kg).
9. Postural support devices such as pelvic positioning belts, anterior trunk supports, or postural supports such as lateral trunk supports should not be relied on for occupant restraint in a moving vehicle unless they are labeled as conforming to ISO Standard 16840-4.

### III. GENERAL WARNINGS

- 10. Alterations or substitutions should not be made to the structure of the chair or seating system, parts, and/or components without consulting the manufacturer.
- 11. Back mounting bracket must be attached in the “leg up” position for transit use (see below). Refer to the appropriate section for correct back hardware mounting instructions.

If you fail to heed these warnings, damage to your chair, a fall, tip-over, or loss of control may occur and cause severe injury to the rider or others.

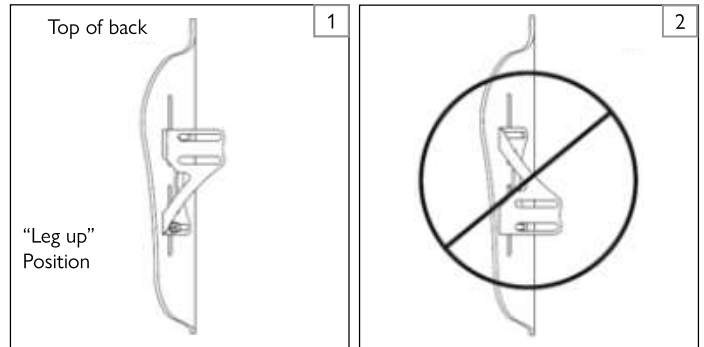

Correct bracket orientation for transit

Incorrect bracket orientation for transit

## IV. USE AND MAINTENANCE

### WARNING

The owner of this equipment is responsible for making sure that it has been set up and adjusted by an Authorized Dealer under the advice of a healthcare professional. It may require periodic safety and function checks or certain in-use adjustments that can be performed by the owner, caregiver, or Authorized Dealer if desired.

#### A. MAINTENANCE AND CLEANING

1. Proper maintenance and cleaning will improve performance and extend the useful life of your equipment.
2. Clean your equipment regularly. This will help you find loose or worn parts and make your equipment easier to use. You will need a mild detergent solution and cleaning rags.
3. If discovered, have loose, worn, bent, or damaged parts replaced **before using the J3 Plus Back.**

#### B. CRITICAL SAFETY CHECKS

1. Fasteners  
Sunrise Medical recommends that all fasteners be checked for wear, such as loose bolts or broken components **every 6 months.** Loose fasteners should be re-tightened according to the installation instructions.
2. Replacing Components  
Contact your Authorized Dealer immediately to replace any components. Do not continue to use the system after identifying loose or broken components.

#### C. EASY CLEANING

1. Back Cover 3
  - a. Remove the cover from back shell by detaching the Velcro® and the snaps. Unzip the bottom of the cover.
  - b. Remove the foam and turn the cover inside out.
  - c. Zip the cover closed to avoid snagging.
  - d. Machine wash in warm water (122° F).
  - e. Drip and tumble dry on low heat.

NOTE - Do not dry clean covers or use industrial washers to clean covers. Do not steam autoclave. Do not bleach. Laundry care symbol definitions are shown. (Fig. 3)

2. Backshell
  - a. The back shell should be wiped clean with soap and water on a regular basis to prevent buildup of dirt and grime.
3. Positioning components
  - a. Remove the components one at a time, noting the placement for re-assembly.
  - b. Positioning components can be wiped clean with soap and water.
  - c. DO NOT immerse positioning components underwater.

(Back Cover) Laundry Care Symbols <span style="float: right; border: 1px solid black; padding: 0 2px;">3</span>	
	Machine wash in warm water (50° C)
	Only non-chlorine bleach, when needed
	Drip dry
	Do not iron
	Do not dry clean

D. REMOVAL AND REPLACEMENT 4

After installation/adjustment, the back can be easily removed from the wheelchair if necessary.

1. Removal:
  - a. Push both release levers forward to unlock the hardware. (Fig. 4)
  - b. Once both levers are in the forward position, lift the back straight up, using the handle located on the top of the back.
2. Proper re-attachment after removal:
  - a. To re-attach the back and hardware receivers, line up the pins to the receivers.
  - b. Push the back into place on the receivers.
  - c. If properly inserted, the pins will “click” into a locked position.

3. Locking Pins:

The locking pins provide a safety feature which prevents the back from being released unintentionally from the wheelchair.

- a. To lock, insert the pins (A) into the mounting receivers (B).
- b. Remove the pins if the quick-release capability is desired.

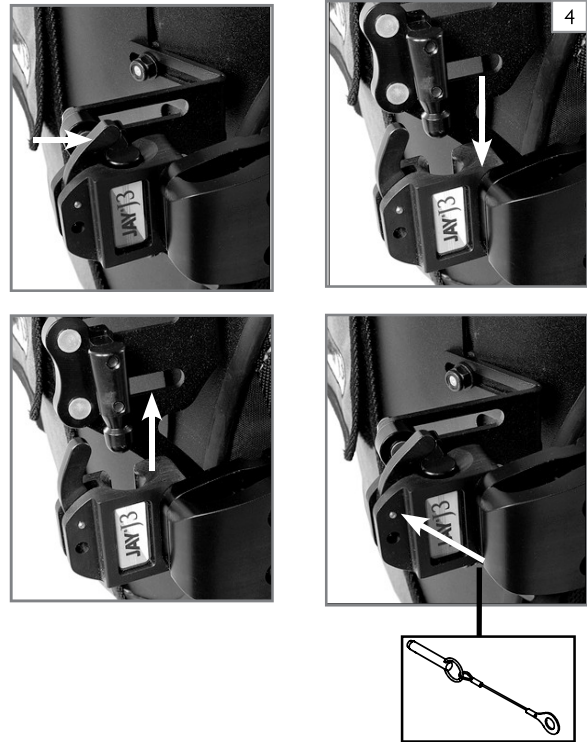

**⚠ WARNING**

If you are uncertain that you have heard the locking “click”, pull up on the back using the handle to test and make sure it has been securely locked.

If you fail to heed this warning, damage to your equipment, a fall, or loss of control may occur and cause severe injury to the rider or others.



## V. FITTING THE BACK TO THE CHAIR

### **⚠ WARNING**

The owner of this equipment is responsible for making sure that it has been set up and adjusted by an Authorized Dealer under the advice of a healthcare professional. It may require periodic safety and function checks. Adjustments should be performed by your Authorized Dealer. Always use parts and/or accessories that have been recommended or approved by Sunrise Medical.

The J3 Plus Back is designed to be compatible with most wheelchairs with the following exception: Wheelchairs that are angle adjustable with recline or tilt that result in a back angle greater than 60° from the vertical should not be used with the J3 Plus Back system.

#### A. WHEELCHAIR DIMENSIONS 5 6

1. The J3 Plus Back is designed to replace the wheelchair's sling upholstery. Prior to installation, determine if the wheelchair used has compatible back canes by measuring the width between your back canes as seen in Fig. 5.
2. Next check that the back canes are compatible diameter. The J3 Plus back hardware can be mounted on wheelchair back canes ranging from 3/4-in to 1-1/8-in. Measure your back cane diameter (Fig. 6) and refer to Table 2 to ensure your back canes are compatible.
3. If you cannot determine that the back canes are compatible, please contact your Sunrise Medical Authorized Dealer or Sunrise Medical customer service.

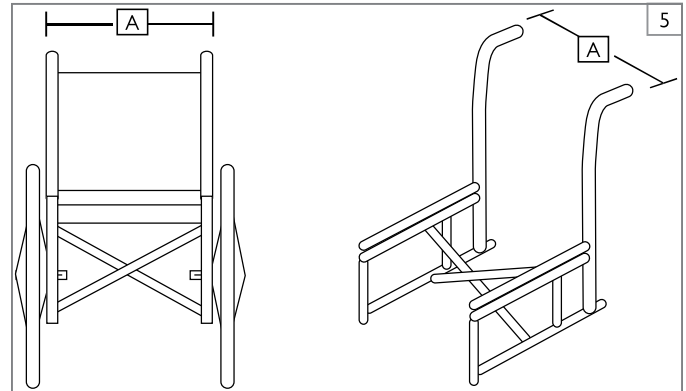

J3 Plus Back Width	Width of back canes from outside to outside of the tubes (A)			
	Minimum Width		Maximum Width	
	inch	cm	inch	cm
22-in	21.7	55.1	24.3	61.7
24-in	23.7	60.2	26.3	66.8
26-in	25.7	65.3	28.3	71.9

\* Back Width is identified in your back's part number.  
Example: Part number J3PLUSPAT22TH is a 22-in back.

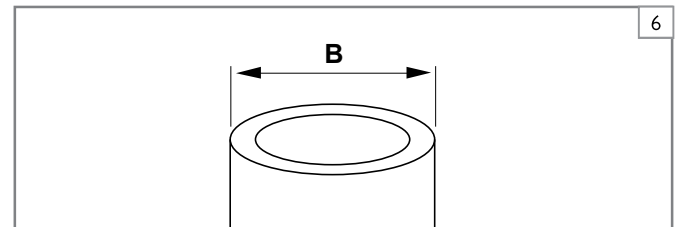

J3 Plus Back Width	Cane Diameter (B)			
	Minimum Width		Maximum Width	
	inch	cm	inch	cm
22-in - 26-in	3/4	1.9	1-1/8	2.85

A. J3 TH HARDWARE

Please read the following instructions before beginning the installation. To install the J3 Plus Back with TH hardware, it is best to begin without a user in the wheelchair. Once the back has been installed, the user can be seated back in the wheelchair for minor adjustments.

1. Tools Required (included with J3 Plus Back):
  - a. 4mm hex key
  - b. 10mm box end wrench

B. BACK HARDWARE INSTALLATION 7 8 9 10

1. Remove existing back components
  - a. Remove the existing wheelchair back according to the wheelchair manufacturer's instructions.
  - b. Remove any pre-existing back hardware or components.
2. Locating the hardware receiver
  - a. The backshell should come with mounting brackets (A) attached.
  - b. Visually determine the optimum clamp receiver location (B) on the back canes. The mounting hardware should be at approximately equal heights on each back post (Fig. 7) and parallel to the seat frame (Fig. 8).

NOTE - A higher location on the back canes is generally better.

3. Attaching the hardware receivers
  - a. Using the 4mm hex key, loosen the clamp screws (C). (Fig. 9)

NOTE - For large tube diameters, the clamp screws may have to be removed completely.

  - b. Attach and align the receiver to the wheelchair back canes (D).
  - c. Hand-tighten the clamp screws (C).
  - d. The receivers may require additional lateral adjustments to ensure proper alignment.

4. Attaching and aligning the J3 Plus Back shell
  - a. Using a 10mm wrench, loosen the bracket nuts (E) and mounting pin bolts (H) until the hardware can move easily in all directions.
  - b. Attach the J3 Plus Back to the hardware receivers by inserting left and right mounting pins (F) in the left and right receivers (G).
  - c. Locate the back to the approximate location, relative to both the chair and the user.
  - d. Tighten bolts on the inside of the mounting pin (F). The recommended torque specification is 11.3-12.4 Nm [100-110 in-lbs].
  - e. Once all components have been properly aligned, tighten the clamp screws (C) to approximately 8.5-9.3 Nm [75-85 in-lbs].
  - f. Finish by inserting the locking pin into the receiver and releasing a few times to ensure smooth operation.

NOTE - Back depth and angle may require additional adjustment to ensure proper fit to the user.

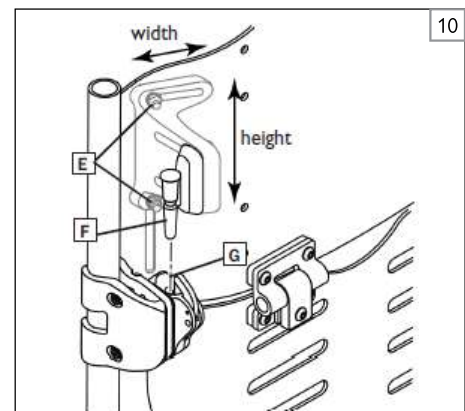
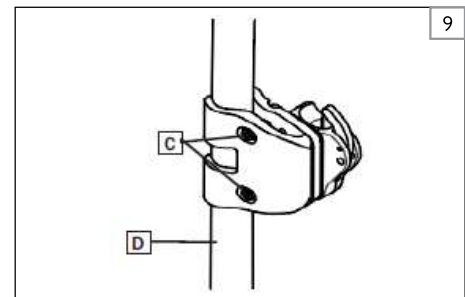
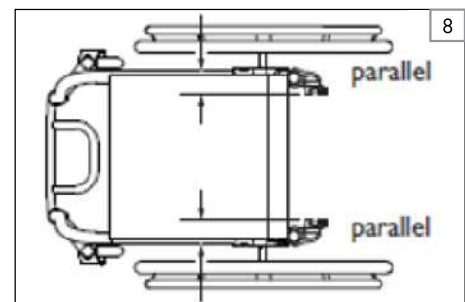
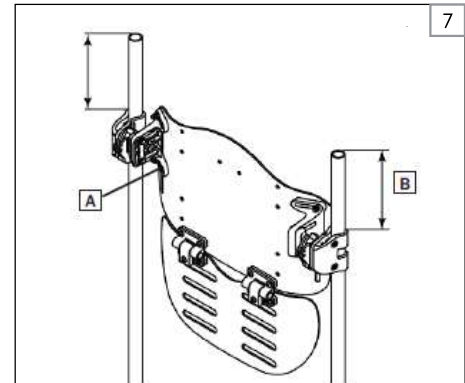

## VI. INSTALLATION & ADJUSTMENT

### C. J3 PLUS FS HARDWARE 12 13 14 15 16

Please read the following instructions before beginning the installation. To install the J3 Plus Back with 4-point hardware, it is best to begin without a user in the wheelchair. Once the back has been installed and minor adjustments are needed, the user can be seated back in the wheelchair.

1. Tools required (included with J3 Plus Back):
  - a. 4mm hex key
  - b. 10mm box end wrench
2. Remove existing back components
  - a. Remove the existing wheelchair back according to the wheelchair manufacturer's instructions.
  - b. Remove any pre-existing back hardware or components.
3. Locating the hardware receivers
  - a. The backshell should come with mounting brackets (A) attached.
  - b. Visually determine the optimum clamp receiver location (B) on the back canes. The mounting hardware should be at approximately equal heights on each back post (D) and parallel to the seat frame. (Fig. 12)

NOTE - A higher location on the back canes is generally better.

4. Attaching the hardware receivers 13
  - a. Using the 4mm hex key, loosen the clamp screws. (C)

NOTE: - For large tube diameters, the clamp screws may have to be removed completely.

  - b. Attach and align the receiver to the wheelchair back canes.
  - c. Hand tighten the clamp screws (C).
  - d. Using a 10mm wrench, loosen the bracket nuts (E) (Fig. 14) and mounting pin bolts (I) (Fig. 15) until you can move the hardware easily in all directions for adjustment.
  - e. The receivers may require additional lateral adjustments to ensure proper alignment.

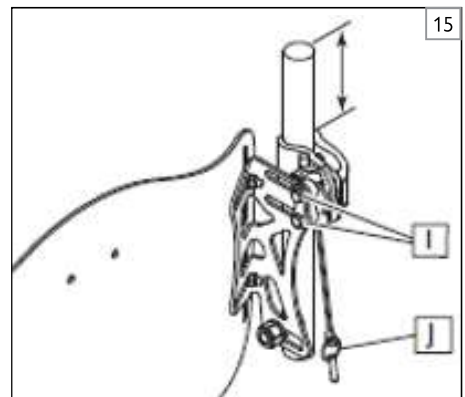
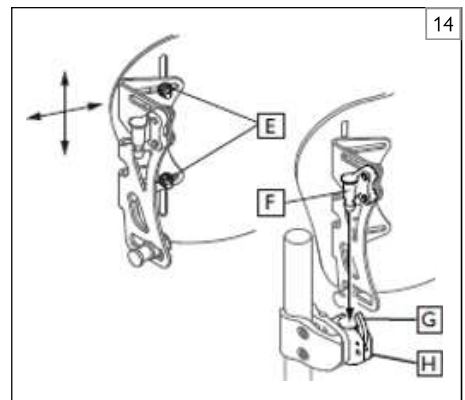
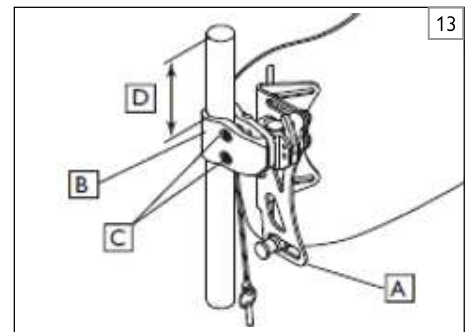
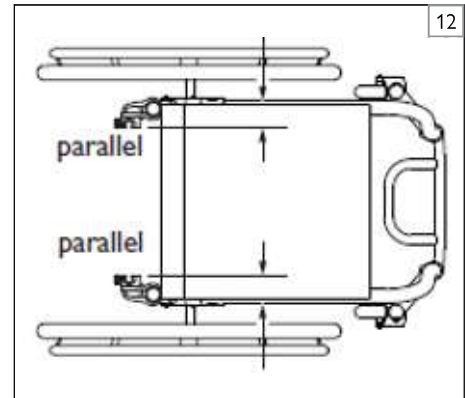

5. Attaching and aligning with the upper hardware receivers. 14 15
- a. Attach the J3 Plus Back to the hardware receivers by inserting left and right mounting pins (F) in the left and right receivers (H).
  - b. Locate the back to the approximate location relative to both the chair and the user.
  - c. Tighten bolts on the inside of the mounting pin (I) (Fig. 15) to a torque of 11.3-12.4 Nm [100-110 in-lbs].
  - d. Tighten the bracket nuts (E) to a torque of 8.5-9.3 Nm [75-85 in-lbs].
  - e. Test the back release by pressing the release levers (G) forward and removing the back off the chair. Proper alignment of the mounting hardware and back is correct when it is possible to have a smooth attachment and release of the back assembly.

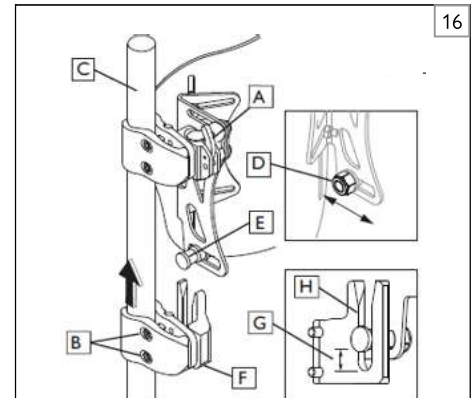

6. Attaching and aligning the lower hardware receivers 16

NOTE - Make sure the upper and lower brackets are aligned and parallel to the seat frame.

- a. Test the back release for the upper mounting hardware by pressing the release levers (A) forward and removing the back from the chair. Proper alignment of the mounting hardware and back can be determined by the smooth attachment and release of the back assembly.
- b. If needed, continue small adjustments until the back can be attached and/or removed smoothly.
- c. Loosen screws (B) to install lower receivers on back canes (C).
- d. Using a 5/8-in wrench, loosen the nut (D) that secures the lower mounting pin (E) so that it slides fore and aft.
- e. Slide lower receiver up (F) until it surrounds the lower mounting pin (E).

NOTE - Leave 1/8-in to 1/4-in of space between the bottom of the lower mounting pin (G) and the bottom of the lower receiver channel (H).

- f. Once properly aligned, tighten the hardware receiver clamp screws (B). The recommended torque is 8.5-9.4 Nm [75-85 in-lbs]. Then tighten the lower mounting pin nut (D) and torque to 11.3-12.4 Nm [100-110 in-lbs].
- g. Finish by inserting the locking pin (H) into receiver. (Fig. 16).

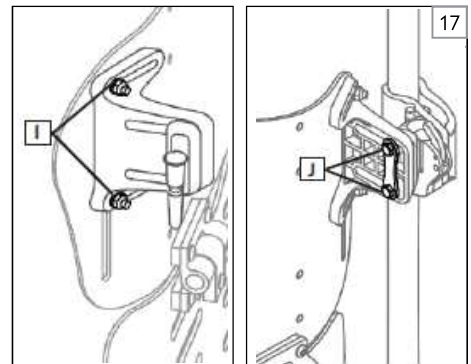

## VI. INSTALLATION & ADJUSTMENT

### 7. Function check and micro adjustments to height, depth, and angle.

13 14 15 17

- Attach the J3 Plus Back to the top and bottom mounting hardware receivers and push down until the assembly is locked. There should be a click when locked properly.
- If needed, continue small adjustments until the back can be attached and/or removed smoothly and locks correctly into the mounts.
- To make micro-adjustments, loosen bolts (I) and (J). This will allow for minor changes in height, depth, and angle. Re-tighten all bolts to required specs and test back function and quick-release.
- To make macro-adjustments, loosen, but do not remove, bolts (A), (C) and (G). (Fig. 13, 14, and 15). Position backrest to desired height, depth, and angle.
- Re-tighten all bolts to required specs and test back function and quick-release.

### 8. ADJUSTING J3 PLUS BACK HEIGHT, DEPTH AND ANGLE 16 17

Once the initial installation is complete, adjustments can be made with the user seated in the chair for a personalized fit. Make sure that the user does not apply full to the back until the hardware has been fully tightened to the specified torque requirements.

#### 1. Height adjustment

- With the user seated in the chair, identify the correct height of the back.
- Have the user slide forward slightly and loosen the nuts (I) with 10mm wrench.
- Move back to correct height and tighten the nuts to 8.5-9.3 Nm [75-85 in-lbs].

#### 2. Depth and angle adjustment

Tilt (TH) and 4-point (FS) hardware has approximately 2 inches of depth adjustment.

- Using a 10mm wrench, loosen the left and right hex screws (J) on the bracket slots.
- Adjust the depth and/or angle settings and securely tighten the screws to lock in the adjustment. Recommended torque specification is 11.3-12.4 Nm [100-110 in-lbs].
- If additional depth is needed, remove the J3 Plus Back from the receivers. Remove the screws (K) from the receiver using a 4mm hex key and reposition the hardware to the desired depth.
- After adjusting to the correct depth, tighten the screws to 2.8-4 Nm [25-35 in-lbs].

### 3. Vanity Shell Extension Adjustment 18

- Using a 5/32 Allen Wrench, loosen the button head cap screw (A) on both hinges to allow rotation of the vanity flap.
- Rotate the vanity flap into the desired position.
- Tighten both button head cap screws (A) to secure the vanity flap in position.

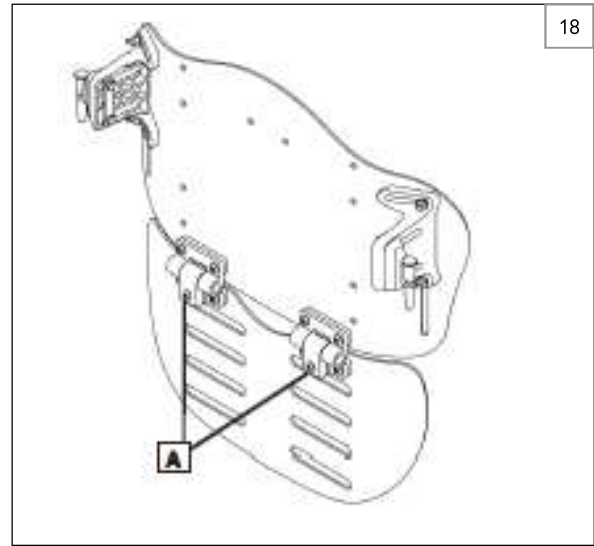

### E. CHECK OUT

#### **⚠ WARNING**

Ensure that all hardware has been properly tightened according to suggested specifications.

- Make sure the J3 Plus Back is locked and the locking pin is inserted into the receiver.
- Check that the J3 Plus Back can be attached smoothly and securely by attaching and removing the assembly several times.
- Double check fit and comfort for the user before putting the J3 Plus Back into use.
- Failure to follow this check out procedure could result in injury and/or damage to your J3 Plus Back and/or components.

A. VANITY FLAP INSTALLATION (Option) 19 20 21

Please read the following instructions before beginning the installation. To install the Vanity Flap it is best to begin without a user in the wheelchair. Once the Vanity flap has been installed the user can be seated back in the wheelchair.

1. Upper and lower attachment flaps 19
  - a. Lift upper flap (A) of J3 Plus Back Cover.
  - b. Attach the lower Flap (B) to the Backshell (hook and loop).
  - c. Match hook to loop and attach Vanity Flap (C) to the back of the Lower flap of the J3 Plus Back Cover.
  - d. Reposition upper flap of cover to sandwich the Vanity Flap between the upper and lower flaps.
  
2. Vanity flap and cushion 20 21
  - a. Remove Seat Cushion from wheelchair and sandwich the "tail" (D) of the Vanity Flap between seat sling and the Seat Cushion.
  - b. Adjust the Vanity Flap (D) as necessary by moving the tail in or out from under the Seat Cushion. If necessary the upper part of the vanity flap can be moved up or down on the Seat Back also.
  - c. At the rear of the chair, Insert Hook and Loop Wrap ties (E) (Fig. 21) through the appropriate grommets on the Vanity Flap, then wrap around the wheelchair frame and insert the leading end through the slot end of the Wrap. Snug up and close outside gaps in Vanity Flap.

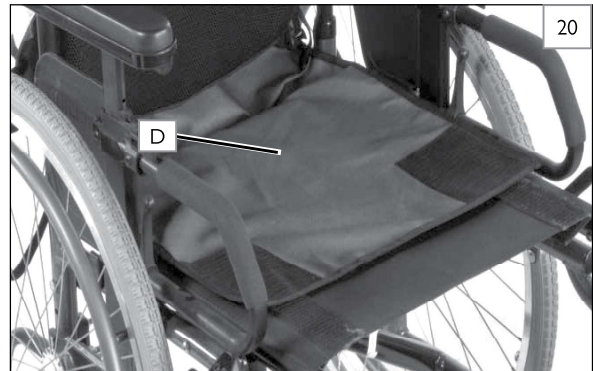

B. SPINE ALIGN POSITIONING COMPONENTS (option) 22 23

Spine Align Positioning Components are designed to provide intimately shaped support within an "off-the-shelf" back. Depending on your market, Spine Align components may be included with your back. Shown below are some typical components that can be used with your J3 Plus Back Spine Align system.

Positioning Components	
Large Lumbar	
Small Lumbar	
Wedge	
Curved Shim	
Flat Shim	
Posterior/Lateral Pelvic	
Lateral Shim	
Large Bean Bag	
Small Bean Bag	

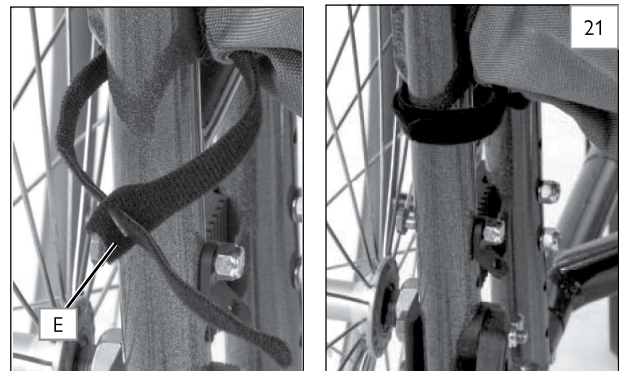

## VII. ACCESSORIES

1. Spine Align Positioning Components Installation 22 23
  - a. Have the user remove pressure from the J3 Plus Back by leaning or sliding partially forward if possible.
  - b. Release Velcro® strip on the top cover flap and lift the cover forward to reveal the inside of the J3 Plus Back.
  - c. Place the positioning component(s) (A) on the Velcro® inside of the shell and re-attach the foam and cover assembly. Pull down, making certain that the top seam is aligned with the top of the shell. If seam does not line up, the bottom of the cover may need to be loosened.
  - d. Have the user test the current Spine Align setup for comfort and support and repeat steps a-c until adjustment is complete.
  - e. Multiple configurations and combinations of Spine Align components can be used. If additional shapes or sizes are required, please contact your dealer or Sunrise Medical at (800) 333-4000.

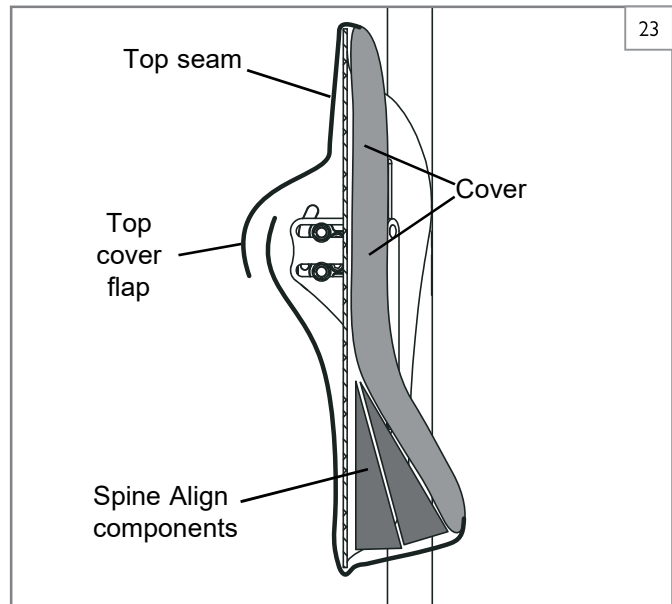

## 24 MONTH LIMITED WARRANTY

1. Each Jay J3 Plus Back is carefully inspected and tested to provide peak performance. Every Jay J3 Plus Back is guaranteed to be free from defects in materials and workmanship for a period of 24 months from the date of purchase, provided normal use. Should a defect in materials or workmanship occur within 24 months from the original date of purchase, Sunrise Medical will, at its option, repair or replace it without charge. This warranty does not apply to punctures, tears or burns, nor to the back's removable cover.
2. Claims and repairs should be processed through the nearest authorized supplier. Except for express warranties made herein, all other warranties, including implied warranties of merchantability and warranties of fitness for a particular purpose are excluded. There are not warranties which extend beyond the description on the face hereof. Remedies for breach of express warranties herein are limited to repair or replacement of the goods. In no even shall damages for breach of any warranty include any consequential damages or exceed the cost of non-conforming goods sold.

Sunrise Medical S.r.l.  
Via Riva, 20 – Montale  
29122 Piacenza  
Italia  
Tel.: +39 0523 573111  
www.SunriseMedical.it

Sunrise Medical AG  
Erlenauweg 17  
CH-3110 Münsingen  
Schweiz/Suisse/Svizzera  
Tel +41 (0)31 958 3838  
www.SunriseMedical.ch

Sunrise Medical AS  
Delitoppen 3  
1540 Vestby  
Norge  
Telefon: +47 66 96 38 00  
post@sunrisemedical.no  
www.SunriseMedical.no

Sunrise Medical AB  
Neogatan 5  
431 53 Mölndal  
Sweden  
Tel.: +46 (0)31 748 37 00  
post@sunrisemedical.se  
www.SunriseMedical.se

MEDICCO s.r.o.  
H – Park, Heršpická 1013/11d,  
639 00 Brno  
Czech Republic  
Tel.: (+420) 547 250 955  
Fax: (+420) 547 250 956  
www.medicco.cz  
info@medicco.cz  
Bezplatná linka 800 900 809

Sunrise Medical Aps  
Mårkærvej 5-9  
2630 Taastrup  
Denmark  
+45 70 22 43 49  
info@sunrisemedical.dk  
www.SunriseMedical.dk

Sunrise Medical Australia  
11 Daniel Street  
Wetherill Park NSW 2164  
Australia  
Ph: +61 2 9678 6600  
Email: enquiries@sunrisemedical.com.au  
www.SunriseMedical.com.au

Sunrise Medical (US) LLC  
North American Headquarters  
12002 Volunteer Blvd.  
Mount Juliet, TN 37122, USA  
(800) 333-4000  
(800) 300-7502  
www.SunriseMedical.com



© 2025 Sunrise Medical (US) LLC  
252148 Rev. B

Sunrise Medical GmbH  
Kahlbachring 2-4  
D-69254 Malsch  
Deutschland  
Tel.: +49 (0) 7253/980-0  
Fax: +49 (0) 7253/980-222  
www.SunriseMedical.de

Sunrise Medical Ltd.  
Thorns Road  
Brierley Hill  
West Midlands  
DY5 2LD  
England  
Phone: 0845 605 66 88  
Fax: 0845 605 66 89  
www.SunriseMedical.co.uk

Sunrise Medical S.L.  
Polígono Bakiola, 41  
48498 Arrankudiaga – Vizcaya  
España  
Tel.: +34 (0) 902142434  
Fax: +34 (0) 946481575  
www.SunriseMedical.es

Sunrise Medical Poland  
Sp. z o.o.  
ul. Elektronowa 6,  
94-103 Łódź  
Polska  
Telefon: + 48 42 275 83 38  
Fax: + 48 42 209 35 23  
E-mail: pl@sunrisemedical.de  
www.Sunrise-Medical.pl

Sunrise Medical B.V.  
Defensiedok 20  
3433 NE Nieuwegein  
The Netherlands  
T: +31 (0)30 – 60 82 100  
F: +31 (0)30 – 60 55 880  
E: info@sunrisemedical.nl  
www.SunriseMedical.nl

Sunrise Medical HCM B.V.  
Vossenbeemd 104  
5705 CL Helmond  
The Netherlands  
T: +31 (0)492 593 888  
E: customerservice@sunrisemedical.nl  
www.SunriseMedical.nl  
www.SunriseMedical.eu (International)

Sunrise Medical S.A.S  
ZAC de la Vrillonnerie  
17 Rue Mickaël Faraday  
37170 Chambray-Lès-Tours  
Tel : + 33 (0) 2 47 55 44 00  
Email: info@sunrisemedical.fr  
www.SunriseMedical.fr

Sunrise Medical Canada Inc.  
1000 Creditstone Rd., Unit #2  
Concord, ON, L4K 4P8  
Canada  
Phone: 1-800-263-3390  
Fax: 1-800-561-5834  
www.SunriseMedical.ca