



Seating System

P/N 247554

Q700 M SEDEO[®] ERGO
Seating manual

Instructions For Use

We at Sunrise Medical want you to get the best out of your wheelchair. This Owner's Manual will familiarize you with the chair and its features. It contains hints on everyday usage and general care in addition to information on the high quality standards which we adhere to and details about the guarantee.

Your wheelchair should be delivered fully configured for your use; there are a wide range of components and adjustments available. For further information about these you should contact your Sunrise Medical authorized dealer.

Your wheelchair will reach you in excellent condition having been personally inspected before leaving our factory. Following the guidelines for maintenance and cleaning your wheelchair will maintain its first class condition and give you complete satisfaction

The wheelchair has been designed for use by an individual on a daily basis. It is suitable for both indoor and outdoor use. It is only intended for use as a pavement vehicle, but may also be used when crossing between pavements.

This vehicle has been designed for a single occupant of limited mobility who has the cognitive, physical and visual ability to control the vehicle safely. See pages 10 and 12 for maximum user weights. If you are in any doubt as to the suitability of the wheelchair, contact your local Sunrise Medical approved supplier for clarification, prior to commencing use.

It is very important to read the relevant section of the owner's manual when making any minor adjustments. Consult your local Sunrise Medical authorized dealer for more complex adjustments.

If you have any queries about the use, maintenance or safety of your wheelchair, please contact your local approved Sunrise Medical service agent. If you do not know of an approved dealer in your area or have any other questions please write or telephone.



DISPOSAL AND RECYCLING INFORMATION

When this product reaches the end of its life, please take it to an approved collection or recycling point designated by your local or state government. This Seating system is manufactured using a variety of materials. Your product should not be disposed of as ordinary household waste. You should dispose of your system properly, according to local laws and regulations. Most materials that are used in the construction of this product are fully recyclable. The separate collection and recycling of your product at the time of disposal will help conserve natural resources and ensure that it is disposed in a manner that protects the environment.

Ensure you are the legal owner of the product prior to arranging for the product disposal in accordance with the above recommendations.

Thank you for choosing a Quickie Power Chair. We want to hear your questions or comments about this manual, the safety and reliability of your system, and the service you receive from your authorized dealer. Please feel free to write or call us at the address and telephone number below:

Sunrise Medical (US) LLC
Customer Service Department
2842 N. Business Park Ave
Fresno, CA 93727 USA
(800) 333-4000

Be sure to return your warranty card, and let us know if you change your address. This will allow us to keep you up to date with information about safety, new products, and options to increase your use and enjoyment of this base system.

You can also register your wheelchair at: www.sunrisemedical.com/register or use the quick response code below.

FOR ANSWERS TO YOUR QUESTIONS

Your authorized dealer knows your wheelchair best, and can answer most of your questions about system safety, use and maintenance. For future reference, fill in the following:

Supplier: _____

Address: _____

Telephone: _____

Serial #: _____ Date/Purchased: _____

INFORMATION YOU SHOULD KNOW

No component of this system was made with Natural Rubber Latex.



www.sunrisemedical.com/register

Dealer signature and stamp

Contents

1.0 User information.....	4	5.0 Setting up the seating system.....	13
1.1 This user manual.....	4	5.1 Pre-set seat width.....	13
1.2 For further information	4	5.2 Pre-set armrests (standard Q700 M Ergo)	14
1.3 Symbols used in this manual.....	4	5.3 Pre-set Leg Rests and footplates (standard Q700 M Ergo).....	15
2.0 Safety	5	5.4 Pre-set seat depth.....	16
2.1 Seating related symbols and labels used on the product	5	5.5 Pre-set headrest	16
2.2 Safety: Temperature	5	5.6 Swing-away controller bracket	17
2.3 General Warnings	6	5.7 Check after setup and/or adjustment of wheelchair..	17
2.4 Safety: Moving parts.....	7	6.0 Seating positioning accessories.....	18
2.5 Safety: Choking hazard	7	6.1 Lap strap / seating positioning belt.....	18
2.6 Safety: Accessories Trays	7	7.0 Using the seating system.....	20
2.7 Safety: Stability.....	7	7.1 Getting in and out of the wheelchair (Transferring)	20
3.0 Warnings for components and options	8	7.2 (Powered) seating options.....	22
3.1 Armrests	8	7.3 Electric seating function.....	23
3.2 Cushions	8	7.4 Seat memory position	23
3.3 Fasteners.....	8	7.5 Retrieving a memory seat position.....	24
3.4 Footplate and footrests	8	7.6 Return to drive mode.....	24
3.5 Positioning belts	8	7.7 Saving a new position to memory.....	25
3.6 Push handles	8	7.8 Delete programmed memory position.....	25
3.7 Seating systems	8	7.9 Return to drive mode.....	25
3.8 Upholstery fabric	9	8.0 Maintenance and cleaning.....	26
3.9 Wiring and connectors	9	8.1 General Maintenance.....	26
3.10 Assignable controls.....	9	8.2 Cleaning your seating system.....	27
3.11 Power seating safety	9	8.3 Hygiene measures when being re-used.....	27
3.12 Power recline	10	8.4 General cleaning instructions	27
3.13 Power leg rest	10	8.5 Cleaning Accessories	28
3.14 Tilt or lift/tilt combo	10	8.6 Storage.....	28
3.15 C-ME® lift	10	9.0 Technical specifications	29
3.16 Swing away joystick arm	10	9.1 Applicable norms / standards.....	29
3.17 Transit.....	11	10.0 Guarantee / Warranty.....	30
4.0 General description	12		
4.1 Maximum user weight.....	12		





1.0 User information

Congratulations on choosing a Sunrise Medical wheelchair. Sunrise Medical's high-quality mobility products are designed to enhance independence and make your everyday life easier.

1.1 This user manual

This user manual will help you to use and maintain your seating system safely. This seating manual is a supplement to Sunrise Medical's general wheelchair user manual.

When necessary this general user manual refers to other manuals as shown below:

-  General manual: Refers to the general user manual for the wheelchair.
-  Controller: Refers to the user manual for the controller.
-  J3 Back: Refers to the user manual for the J3 Back Rest.
-  Battery charger: Refers to the user manual for the battery charger.

Do not use your wheelchair until this entire manual (and all other booklets) has been read and understood!

If one of the user manuals was not included with your wheelchair, please contact your dealer immediately.

1.2 For further information

Please contact your local, authorized Sunrise Medical dealer if you have any questions regarding the use, maintenance or safety of your wheelchair. In case there is no authorized dealer in your area or you have any questions contact Sunrise Medical either in writing or by telephone.

For information about product safety notices and product recalls, go to www.SunriseMedical.com

1.3 Symbols used in this manual



DANGER!

Potential risk of injury or serious injury or death



WARNING!

Potential risk of injury.



CAUTION!

Potential damage to equipment.

NOTE:

General user advice.

Not following these instructions may result in physical injury, damage to the product or damage to the environment!

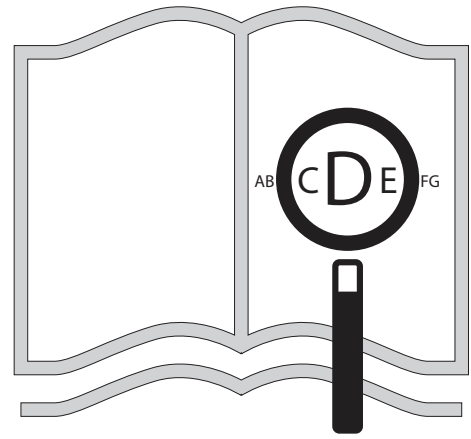

If you are visually impaired,
this document can be viewed
in PDF format at
www.SunriseMedical.com



2.0 Safety

Follow the instructions carefully next to these warning symbols! Not paying careful attention to these instructions could result in physical injury or damage to the wheelchair or the environment. Wherever possible, safety information is provided in the relevant chapter.

2.1 Seating related symbols and labels used on the product

The signs, symbols and instructions affixed to the wheelchair comprise part of the safety facilities. They must never be covered or removed. They must remain present and clearly legible throughout the entire lifespan of the wheelchair.

Replace or repair all illegible or damaged signs, symbols and instructions immediately. Please contact your authorized dealer for assistance.

Fig. 2.1: Transit fixation point.

Fig. 2.2: Warning – Danger of finger entrapment (pinch point).

Fig. 2.3: Warning – Maximum user weight for the wheelchair.

Fig. 2.4: Warning – Ensure that the seat interface thumb screws are screwed in tight before using your wheelchair, especially on a slope.

2.2 Safety: Temperature

WARNING!

- Avoid physical contact with the wheelchair's motors at all times. Motors are continuously in motion during use and can reach high temperatures. After use, the motors will cool down slowly. Physical contact could cause burns. Allow the motors after using at least 30 min. to cool down.
- If you do not use the wheelchair, ensure that it is not exposed to direct sunlight for lengthy periods of time. Certain parts of the wheelchair, such as the seat, the back and the armrests can become hot if they have been exposed to full sunlight for too long. This may cause burns or allergic reactions to the skin.



2.3 Safety: General warnings

DANGER!

- Always ensure that you are able to operate all controls from a comfortable position. Paying attention to your posture is essential to ensure your continued comfort and well being.
- Always make sure that you can be seen clearly. Use the lights, especially if you intend using your seating system in poor light.
- This seating system has been set up to match the needs of a particular user. If used by another user then it may need to be adjusted.
- Do not let children or others use your seating system.
- Avoid spilling liquids on to the controller or its connections. Especially hot, sticky, sugary or corrosive liquids. Such contamination may compromise the safe operation of the control system and damage the seating system upholstery.

WARNING!

DO NOT use any wheelchair that has been involved in a motor vehicle accident. A sudden stop and/or collision may structurally damage your wheelchair. There may have been a change to the structure of the chair, and/or damaged or broken some of the components. Wheelchairs involved in sudden stops should be inspected for possible failures in frame and/or components. Frame damage may be represented by but not limited to: visual cracks, dents, metal distortion, bends, or damage to the seating mounting. If the chair no longer drives straight, it could be damaged. **If the wheelchair has been involved in an accident, discontinue use immediately and contact your Authorized Dealer for a thorough inspection.** If damage is questionable or if there is concern regarding the condition of the chair, Sunrise Medical recommends replacement of the chair.

Wheelchairs involved in collisions should be replaced.

NOTE- The warranty is void on any wheelchair that is involved in a collision.

2.3.1 User

DANGER!

1. Every seating system is different.
2. Take the time to learn the feel of this system before you begin riding.
3. Be aware that you must develop your own methods for the safe use of this system that are best suited to your level of function and ability.
4. Have someone help you practice bending, reaching and transfers until you learn how to do them safely.
5. Never try a new maneuver on your own unless you are sure it is safe.
6. Get to know the areas where you plan to use your system. Look for hazards and learn how to avoid them.
7. Always wear a positioning strap.
8. Do not use a seating system if the joystick does not spring back to the neutral position.
9. Do not use your seating system if the joystick boot is ripped or damaged.
10. Do not try to tip this seating system without an attendant present.
11. Do not allow additional riders, the system may become unstable.

2.3.2 User and Attendants

DANGER!

1. When transferring the user in or out of the seating system never use the footplate as a platform.
2. When transferring the user in or out of the seating system never use the armrest as a means of support.
3. Do not lift this seating system by any parts that are removable, doing so may result in damage to the seating system or injury to the user.
4. Never try to stop or slow this seating system with the wheel locks (if applicable). Wheel locks are designed to prevent the system from moving when stopped. They are not brakes.
5. Always keep your hands and body parts clear of moving parts to help prevent injuries.

2.3.3 Attendants

DANGER!

Make sure you heed all warnings and follow all instructions in each section of this manual. Warnings that apply to the user also apply to you.

1. Do not stand or sit on any portion of this seating system.
2. You need to work with the user, and the user's doctor, nurse or therapist, to develop safe methods best suited to your abilities and those of the user.
3. To manually push the system you must release the motor brakes.
 - Do not engage or disengage motor brakes **unless** power to the system is **off**.
 - Make sure you have full control over the system when you release the motor brakes. When you do so the system will not have brakes.
 - Make sure the system is on level ground before you release the motor brakes.
4. Check to make sure push handle grips will not rotate or slip off.

2.3.4 Attendant control

DANGER!

Make sure you always have comfortable access to the controls while the chair is moving and make sure that the controller is fixed securely to the chair.

1. Set the speed of the attendant control to a speed that you can comfortably follow.
2. Always turn off the power to the controller when leaving the user in the chair.

2.4 Safety: Moving parts

DANGER!

A wheelchair has moving and rotating parts. Contact with moving parts may result in serious physical injury or damage to the wheelchair. Contact with the moving parts of the wheelchair should be avoided Fig. 2.5.

- Wheels (turning and caster)
- Power tilt in space adjustment
- Power seat lift option
- Power recline adjustment
- Swing-away bracket of the controller
- Power elevating legrest

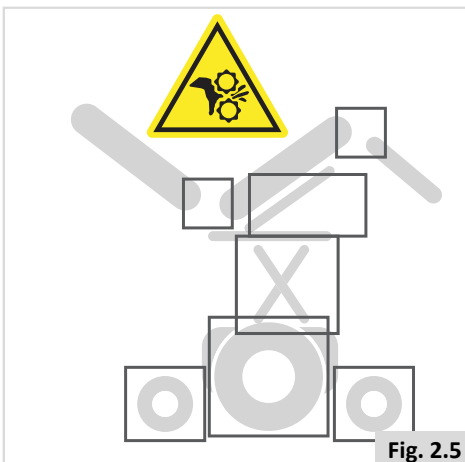

2.5 Safety: Choking hazard

DANGER!

This mobility aid uses small parts which under certain circumstances may present a choking hazard to young children.

2.6 Safety: Accessories Trays:

Safety: Vent tray

DANGER!

Using a vent tray will affect the stability and overall weight of your wheelchair.

- Make sure that the batteries and the ventilator are securely fastened to the tray before use.
- Familiarize yourself with the increased size of the wheelchair before driving to prevent potential collisions.
- When activating the recline backrest make sure that the area around the vent tray is clear.
- Be aware that the vent tray assembly can cause a finger trap hazard when the backrest is reclined.
- The vent tray is not designed to hold anything other than the vent unit and its batteries, it is not designed to hold an O2 bottle etc. Use of these items may cause your wheelchair to become unstable.
- The vent tray must be installed and maintained by a Sunrise Medical authorized dealer.

Safety: Swing away tray

DANGER!

- The maximum load allowed for the tray is 5.5 lbs (2.5 kg).
- Do not overload the tray, this could cause the tray to break or could cause the chair to become unstable.
- Do not leave lit cigarettes or other heat sources on the tray as this could cause the tray to deform and mark.
- Ensure that all extremities and clothing are clear when positioning the tray for use.

2.7 Safety: Stability

WARNING!

- Removing the batteries from the base, or moving the seating system up or backwards, may decrease the stability of the chair and it may tip backwards.
- Only remove the batteries while the chair is on the ground.
- Do not remove the batteries while the chair is on a lift table or on any other elevated surface.

3.0 Warnings for Components and Options

WARNING!

- If you use parts or make changes not authorized by Sunrise it may create a safety hazard and will void the warranty.

3.1 Armrests

WARNING!

1. Armrests will not bear the weight of this system.
2. **Never** lift this system by its armrests. They may come loose or break.
3. When transferring the user in or out of the seating system never use the armrest as a means of support.

3.2 Cushions

WARNING!

1. Standard foam cushions and other body supports are not designed for the relief of pressure.
2. If you suffer from pressure sores, or if you are at risk that they will occur, you may need a special seating system or a device that will help control your posture.
 - Consult your Healthcare Professional to find out if you need such a device for your comfort and health.

3.3 Fasteners

DANGER!

Many of the screws, bolts and nuts on this system are special high-strength fasteners. Use of improper fasteners may cause your system to fail.

1. Only use fasteners provided by Sunrise.
2. If fasteners become loose, tighten them immediately.
3. Do not over- or under-tightened fasteners as this can cause damage to your system or its components.
4. Do not reuse fasteners.

3.4 Footplate and footrests

DANGER!

1. At the lowest point, footrests should be **at least 2"** (51 mm) off the ground. If set too LOW, they may "hang up" on obstacles you can expect to find in normal use. This may cause the system to stop suddenly and tip forward.
2. To avoid a trip or fall when you transfer:
 - Make sure your feet do not "hang up" or get caught in the space between the footrests.
 - Avoid putting weight on the footrests, as the system may tip forward.
 - Remove or swing the footrests out of the way, if possible.
3. The footrest should always be in the down position when operating the system.
4. Never lift this system by the footrests. Footrests detach and will not bear the weight of this system. Lift this system only by non-detachable parts of the main frame.

3.5 Positioning belts

DANGER!

The positioning belt is predominately used to support your posture. It can also be used to limit slipping and/or sliding that you might experience when the system is in motion. The positioning belt is not a transit rated safety belt and should not be used in the place of a seat belt while being transported in a motor vehicle. Improper use of Positioning belts may cause severe injury or death. If you use a positioning belt, be sure to follow the recommendations in this section:

1. Make sure the rider does not slide down in the seating system seat. If this occurs, the rider may suffer chest compression or suffocate due to pressure from the belts.
2. The belts must be snug, but must not be so tight that they interfere with breathing. You should be able to slide your open hand, flat, between the belt and the rider.
3. A pelvic wedge or a similar device can help keep the rider from sliding down in the seat. Consult with the rider's doctor, nurse or therapist to find out if the rider needs such a device.
4. Use positioning belts only with a rider who can cooperate. Make sure the rider or attendant can easily remove the belts in case of emergency.
5. **NEVER** use positioning belts:
 - a. As a patient restraint. A restraint requires a doctor's order.
 - b. On a rider who is comatose or agitated.
 - c. As a motor vehicle restraint. In an accident or sudden stop the rider may be thrown from the system. Seating system seat belts will not prevent this, and further injury may result from the belts or straps.

If you fail to heed these warnings, damage to your system, a fall, tip-over or loss of control may occur and cause severe injury to the rider or others.

3.6 Push handles

DANGER!

1. Push handles provide secure points for an attendant to propel and control the system. This helps to prevent a fall or tip-over.
2. Check to make sure push handle grips will not rotate or slip off.

3.7 Seating systems

DANGER!

1. Use of a seating system not approved by Sunrise may affect or interfere with other parts of the system.
2. **Never** change the seating system unless you consult your authorized dealer first.
3. Never raise your seating system to a height of more than 19" (482mm) (measuring from the front of the seat pan to the floor) with all actuators in their home position.

3.8 Upholstery fabric



1. Replace worn or torn fabric of the seat sling and/or seat back as soon as you possible. If you fail to do so, the seat may fail and cause you to fall. Worn or torn fabrics may increase the potential for a fire hazard.
2. Fabric will deteriorate with age and use. Look for fraying, thin spots, or stretching of fabric at rivet holes. Replace fabric as required.
3. Be aware that washing may reduce flame retardation qualities of the fabric.

3.9 Wiring and connectors



Never pull on cables directly. This can result in wires breaking inside the connector or harness. To remove a plug or connector, always grasp the plug or connector itself.

3.10 Assignable controls:



It is possible to assign a function to an input control (buttons, jacks) to your seating system . If controls have been assigned to perform a dual or alternate function ensure you know what each control operates. Please contact your authorized dealer or the Sunrise technical service department if you do not receive this information. Failure to do so may result in damage and/or injury.

3.11 Power seating safety



1. Operation

- While driving this seating system in the reclined, elevated, or tilted position use caution.
- Do Not attempt to operate any power seating option while positioned on an incline.
- Do Not attempt to operate any power seating option while this seating system is in motion.
- Do not attempt to operate the lift or tilt power seating options around children.
- Through programming it is possible to reverse the direction of all powered seating functions, ensure you know which direction your seat is going to move before operating.

2. Reduced Speed Driving (Creep)

This power system is designed to automatically reduce the maximum driving speed to a creep mode when certain power seating limits are reached. Depending on the configuration of the chair there might be multiple creep speeds.

3. Pinch points

Pinch points may occur when operating the powered seating options on this system. Ensure all hands and body parts are clear of all power seating components that may result in pinch points before operating them.

4. Tilting Power Base with Push Handles

Do not attempt to tilt power wheelchairs by pulling down on the push handles. Power wheelchairs have heavy bases. As such, attempting to tilt a power seating system to traverse obstacles can damage components in the seating system and/or modular actuators.

5. Remain Clear During Power Accessory Operation

Please stay clear of any powered actuator while the component is in motion. Sunrise power mechanisms move over large ranges of travel. Users should be aware of their surroundings while components are in motion.

6. Maximum User Weight

Do not exceed the weight capacity for your specific system/seating system configuration. Doing so could result in premature failure or injury.

7. Latch Mode

While operating any power seating function in latched mode use caution. In latch mode, powered seating will not stop until a reverse command is performed or the end of travel is met.

3.12 Power recline



Trap Point (pinch point)

Avoid putting hands or fingers near the power recline mechanism while in operation.

Weight Capacity

The maximum user weight capacity for the power recline is up to 300 lbs (136 kg), 350 lbs (160 kg) for heavy duty chair. Exceeding this weight capacity could lead to injury and/or permanent damage to the equipment.

3.13 Power leg rest



The power leg rest accessory has a maximum user weight capacity of up to 350 lbs (160 kg) depending on your system configuration. Never exceed this capacity while operating the powered actuator.

3.14 Tilt or tilt/lift combo



Trap Point (pinch point)

Avoid putting hands, fingers, clothing items, or letting children near the seating system when the Tilt/Lift mechanism is in operation.

Weight Capacity

The powered lift/tilt modular accessory for this system has a maximum user weight capacity of up to 300 lbs (136 kg). The powered tilt modular accessory for this system has a maximum user weight capacity of up to 350 lbs (160 kg). Never exceed this capacity while operating the powered actuator.

3.15 C-ME® lift



The C-ME accessory has a maximum user weight capacity of up to 250 lbs (113 kg) with a maximum speed of 3mph or a maximum user weight of 300 lbs (136 kg) with a maximum speed of 2.4mph at full lift. Never exceed this capacity while operating the lift.



Exceeding these weight capacities could lead to injury and/or permanent damage to the equipment.

NOTE - Exceeding the weight limit will void the warranty.

3.16 Swing away joystick arm



Before adjusting the swing-away arm, switch off the controller to avoid accidental displacement of the joystick which would cause unwanted movement of your wheelchair. Be aware that the width of your chair may have increased and you may not be able to go through certain obstacles.



- Only operate the wheelchair at a low and maneuverable speed when the parallel swing-away is in use.
- When transferring to and from the wheelchair, do not use the armrest as a means of support.
- Do not hang any items on or over the parallel swing-away remote assembly as this could damage the swing-away mechanism.

3.17 Transit:



Important Transit notes for the chair:

1. If possible and feasible, the rider should transfer to the (OEM) Original Equipment Manufacturer vehicle seat and use the vehicle restraint.
2. If the seating system is used for transport, it must be used in a forward-facing seating position during travel in a motor vehicle.
3. The recommended clear zones for wheelchair seated occupants restrained by both pelvic and upper-torso belt(s) and only by a pelvic belt are shown in the diagrams (Fig. 3.1 and 3.2) and described below. Frontal Clear Zones (FCZ) need to be larger when upper torso belt(s) are not used. The Rear Clear Zone of 16" (40.5 cm) is measured from the rearmost point on an occupant's head. The Frontal Clear zone is measured from the front most point of an occupant's head and is 26" (66 cm) with pelvic and upper-torso belt(s) and 37" (94 cm) with only a pelvic belt. The frontal clear zone may not be achievable for wheelchair- seated drivers.
4. The estimated seated height (HHT) from the ground or floor to the top of the wheelchair-seated occupant's head ranges from approximately 47" (119 cm) for a small adult female to about 61" (155 cm) for a tall adult male (Fig. 3.2).
5. The rider must not weigh more than 300 lbs (136 kg) or 350 lbs (160 kg) for heavy duty chair.
6. Attach WTORS to securement points in accordance with the manufacturer's instructions and SAE J2249.
7. Ensure hip guides are mounted and are locked in place.
8. Use only Wheelchair Tie-down and Occupant Restraint Systems (WTORS) which meet the requirements of SAE J2249 Recommended Practice– Wheelchair Tie-down and Occupant Restraint Systems For Use in Motor Vehicles. Do not use WTORS designed to rely on the wheelchair structure to transfer occupant restraint loads to the vehicle.
9. In order to reduce the potential of injury to vehicle occupants, wheelchair-mounted accessories, such as trays and respiratory equipment, should be removed from the seating and wheelchair and secured separately.
10. Postural supports and positioning devices should not be relied on for occupant restraint.
11. Do not alter or substitute wheelchair frame parts, components or seating.
12. Sudden stops or impacts can structurally damage your system. Chairs involved in such incidents should be replaced.

Important Transit notes for Occupant restraints:

13. Attach occupant restraints in accordance with the manufacturer's instructions and SAE J2249.
14. Both pelvic and upper torso restraint belts must be used to restrain the occupant to reduce the possibility of head and chest impacts with the vehicle components and serious risk of injury to the user and other vehicle occupants (Fig. 3.3).
15. The upper torso restraint belt (A) should be mounted to the vehicle (B) pillar - failure to do so will increase the risk of serious abdominal injuries to the user (Fig. 3.3).
16. A head restraint suitable for transportation must be fitted and suitably positioned at all times during transportation.
17. The pelvic restraint belt (C) must be worn low across the front of the pelvis so that the angle of the pelvic belt is within the preferred zone of 30 to 75 degrees to the horizontal (Fig. 3.3).
18. A steeper (greater) angle within the preferred zone is desirable, closer to, but not exceeding 75 degrees (Fig. 3.5).
19. The upper torso restraint belt (A) must fit over the shoulder and across the chest (Fig. 3.3).
20. Restraint belts must be adjusted as tightly as possible consistent with user comfort, and should not constrict breathing (Fig. 3.4).

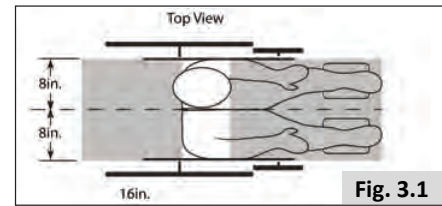

Fig. 3.1

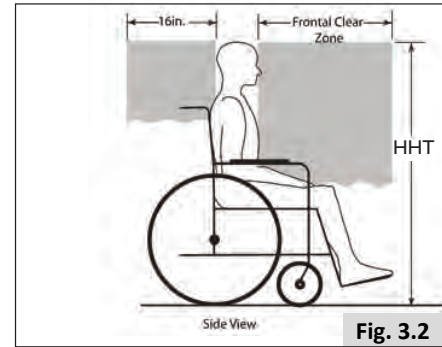

Fig. 3.2

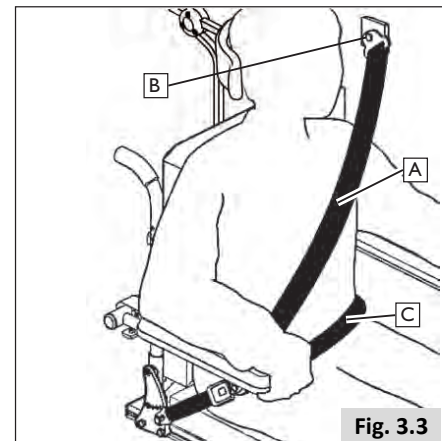

Fig. 3.3

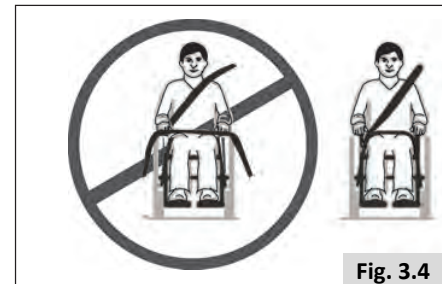

Fig. 3.4

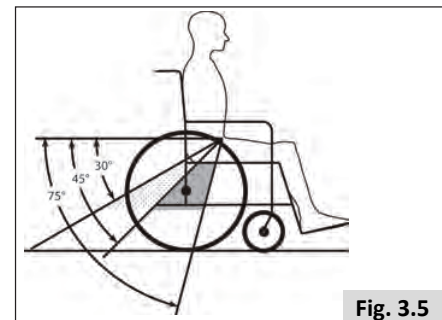

Fig. 3.5

4.0 General description

This wheelchair is equipped with Q700 M Ergo seating system. The Q700 M Ergo seating system provides good support for the head, torso, arms, and legs. Optimal body support ensures maximum independence for the wheelchair user. The wheelchair must be adjusted by a qualified specialist. Incorrect settings may have negative consequences for the seating posture.

Main components: (Fig 4.1)

1. Headrest
2. Joystick
3. Armrest
4. Side cushion
5. Seat cushion
6. Leg rest
7. Back upholstery

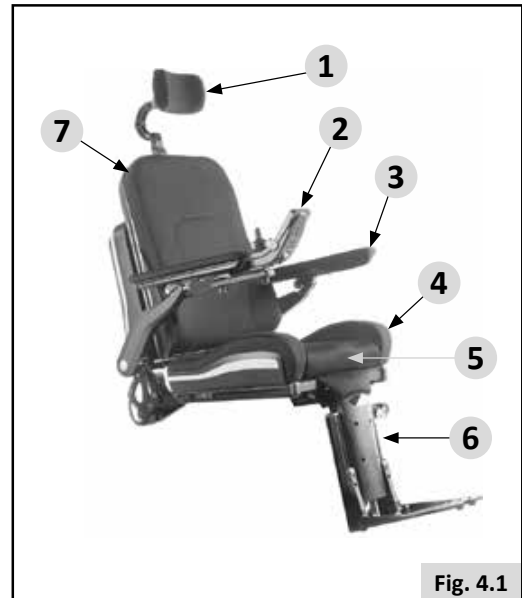

Fig. 4.1

4.1 Maximum user weight:

The overall maximum user weight shall not exceed:

Q700 M Sedeo Ergo MPC	- 300 lbs (136 kg)
Q700 M Sedeo Ergo MPC and C-Me up to 3mph	- 250 lbs (113 kg)
Q700 M Sedeo Ergo MPD	- 300 lbs (136 kg)
Q700 M Sedeo Ergo MPC HD	- 350 lbs (160 kg)

WARNING!

Exceeding these weight capacities could lead to injury and/or permanent damage to the equipment.

NOTE - Exceeding the weight limit will void the warranty.

WARNING!

DO NOT use any wheelchair that has been involved in a motor vehicle accident. A sudden stop and/or collision may structurally damage your wheelchair. There may have been a change to the structure of the chair, and/or damaged or broken some of the components. Wheelchairs involved in sudden stops should be inspected for possible failures in frame and/or components. Frame damage may be represented by but not limited to: visual cracks, dents, metal distortion, bends, or damage to the seating mounting. If the chair no longer drives straight, it could be damaged. **If the wheelchair has been involved in an accident, discontinue use immediately and contact your Authorized Dealer for a thorough inspection.** If damage is questionable or if there is concern regarding the condition of the chair, Sunrise Medical recommends replacement of the chair.

Wheelchairs involved in collisions should be replaced.

NOTE- The warranty is void on any wheelchair that is involved in a collision.

5.0 Setting up the seating system

The average wheelchair user does not exist. This is why Sunrise Medical wheelchairs can be adjusted according to specific needs of the user.

In this, we make a distinction between wheelchair settings and wheelchair seating adjustment options. Settings are carried out once, the first time the wheelchair is going to be used. They must be executed by qualified specialist, unless explicitly stated otherwise. Seating adjustment options can be carried out by the user.

5.1 Pre-set seat width

Pre-set the armrest width:

- Remove the two screws (5.0mm Allen key) on the traversing tube as shown in Fig. 5.1 - A.
- Move the armrest receiver brackets to the desired position
- Install the screws firmly prior to use.

CAUTION!

- Please check that the new arm rest position does not interfere with any seat positioning

Pre-set the seat plate width

Lift the seat cushion off the Velcro® strips to access the seat plates.

- Use a 5.0 mm Allen Key, (Hex Wrench).
- Adjust the seat plate width by loosening the four screws, circled in Fig. 5.2.
- Slide the plates outwards or inwards to achieve the required seat width.
- The seat width is indicated by the scale that runs alongside each slot, Fig. 5.2.
- Tighten the four screws securely.

Pre-set the back plate width

Lift the back cushion off the Velcro® strips to access the back plate, Fig.5.3.

- Use a 5.0 mm Allen Key, (Hex Wrench).
- Loosen all of the 12 screws located within the slots.

Define the back plate width

- Slide the side plates in or out to the required width.
- Tighten the 8 screws securely (white marked in Fig. 5.3).

Positioning/centering the back plate width

- Slide the backrest to the left and the right to align with the marker pin.
- Use the measuring scale embedded on the back plates and the marker pin for reference.
- Tighten all remaining 4 screws securely (black marked in Fig. 5.3).
- Fit a backrest cushion onto the back plate.

CAUTION!

After finishing seat width adjustments, make sure that the armrest can be flipped up without colliding with the backrest. Not doing so can lead to damaging the product.

 J3 Back (Fig 5.3.1):

NOTE: The Jay 3 Backrest can be used in conjunction with the Ergo seating system. Please refer to the J3 Back Owner's Manual for fitting and adjustment.

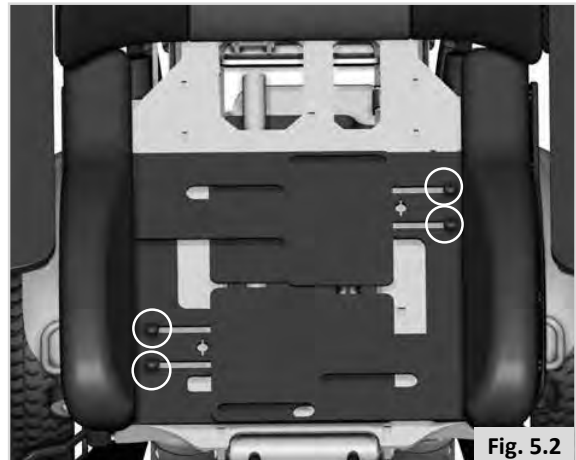
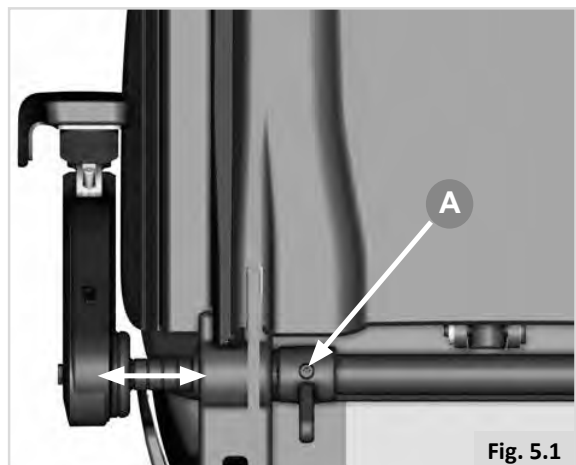

Lift off side cushion

The Q700 M Ergo, has the ability to remove the side support cushion without the use of tools. This facilitates side transfers especially when the chair is fitted with lateral knee or hip supports.

To remove the side cushion:

- Pull the plastic lever that is attached to the aluminum seat side rails backwards (Fig.5.4 - A).
- Swing the back part of the cushion outwards to an angle of approximately 10° - 90°.
- Lift the cushion out from the front pin.

To refit the side cushion:

- Align the pin at the front edge of the seat plate with the hole of the aluminium side rail.
- Slide the rail onto the pin and swing the side cushion all the way in, until the latch locks in with an audible click.
- As with all moving parts be careful not to trap your fingers



Fig. 5.4

5.2 Pre-set armrests (standard Q700 M Ergo)

Pre-set armrest height

The following section outlines armrest height adjustment. In the case of either fine or gross adjustment, it is a two-part process:

PART 1: Adjust the armrest height using the rear pivot.

PART 2: Adjust arm pad angle using the front pivot.

PART 1 (Fig. 5.5)

Up to 5.5" (140 mm) of armrest height adjustment can be achieved using the 0.2" (5.0 mm) fine height adjustment screw to fine tune the armrest's height.

- Use the 5.0 mm Allen key that is stored on the inside of the left hand armrest.
- Turn the screw, (A), at the upper rear pivot and your armrest will move up or down depending on the rotation direction (1) + (2).

PART 2 (Fig. 5.6)

- When your armrest is at the desired height, use the same tool to turn the screw, (B), below the lower front pivot of the armrest.
- This process will set the arm pad angle to the required setting, (2) + (3).

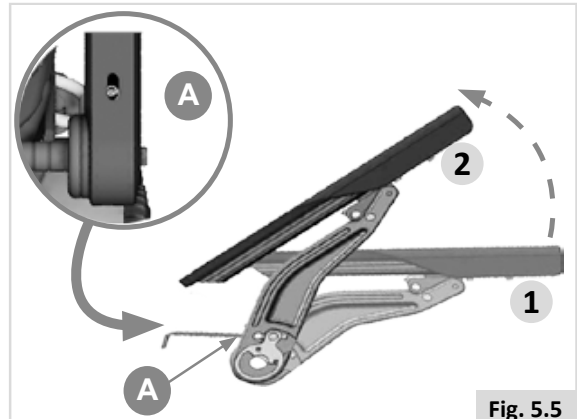

Fig. 5.5

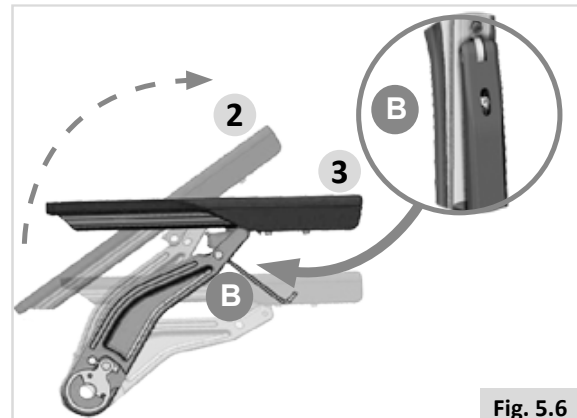

Fig. 5.6

Pre-set the arm pad forward or back: (Fig.5.7)

- Loosen the 2 bolts at the bottom of the arm pad rail.
- Slide the arm pad along the channel nuts.
- At this point some inward and outward angle adjustment is also possible.
- Move the front bolt from front hole to the slot hole, (A).
- Tighten the bolts securely when the angle is set.
- When the correct position is reached tighten the 2 bolts securely with the 5.0 mm Allen Key, (Hex Wrench).
- Place the tool in its original space so it can be used for further adjustments in the future.

WARNING!

All screws should be checked periodically for tightness. A loose arm pad could slip down when pressed.



Fig. 5.7

5.3 Pre-set Leg Rests and footplates (standard Q700 M Ergo)

WARNING!

- Be aware of your environment to make sure you do not injure your legs when Leg Rests are extended.
- Always ensure that the Leg Rests or foot plates do not come into contact with the casters before driving the wheelchair.
- Leg Rests are not to be used for lifting or carrying the wheelchair under any circumstances.
- As with all moving parts be careful not to trap your fingers (Fig.5.8).

Pre-set foot plate height and angle

The power center mount footrest allows angle adjustment from 90° to 180° level to ground and a 7.5" (190 mm) powered length extension.

The left and right footplate can be adjusted by an angle of +/-5.0° and has a mechanical height range adjustment of 3" to 18" (76 mm to 457 mm) measured from the footplate to the seat pan.

Pre-set foot plate height:

- Loosen the 2 bolts (A) with a 5.0 mm Allen key, (Fig.5.9).
- Slide the footplate receiver up or down in the track to the height desired.
- Tighten the 2 bolts securely.
- Repeat for the other side.

Pre-set foot plate angle:

- Flip up the footplate so that you can reach the angle setting screw (B) (Fig.5.10).
- Use a 4mm Allen key to adjust the bolt in or out depending on the angle required.

WARNING!

- After adjustment and with the seat in its normal drive position: Ensure there is a gap of at least 2" (51 mm.), between the floor and the footplate at all times when maneuvering the footplate up or down.
- Perform this test with the user sitting in the chair loading the leg rest.

Using the chair with the leg rest set too low might result in personal injury or damage to the wheelchair and its surroundings.

Pre-set foot plate width:

- Remove bolt (D) with an Allen key (Fig.5.11).
- Move spacer (E) from inside of footrest to the outer side.
- Reinsert bolt and tighten securely.
- Repeat for the other side.

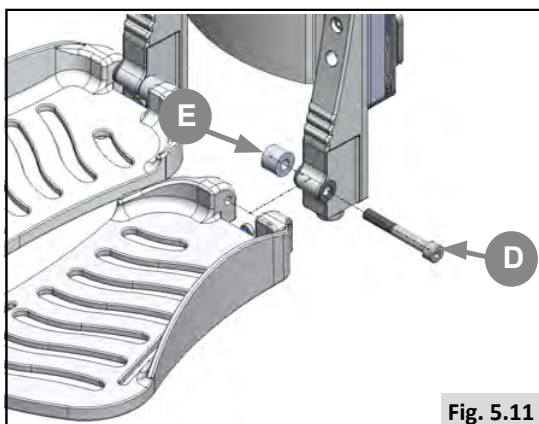
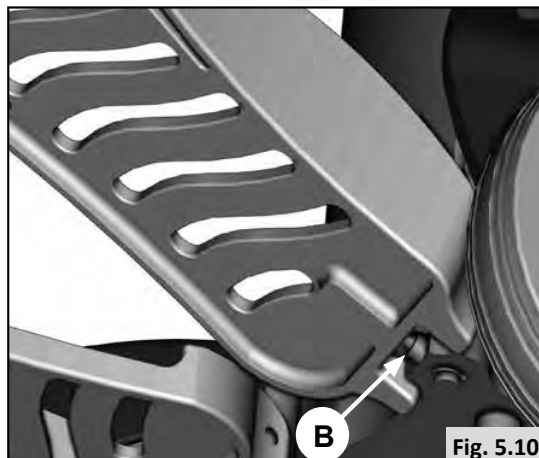
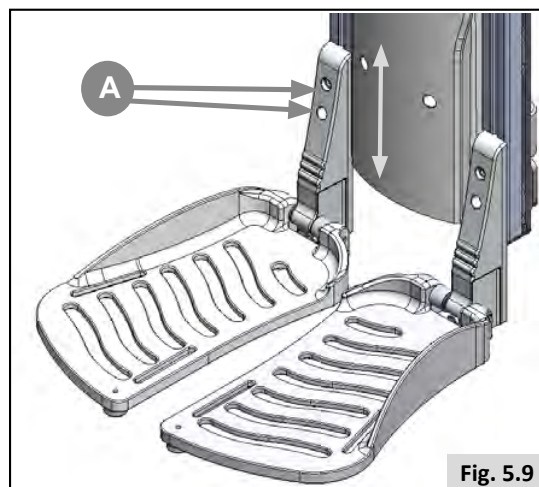
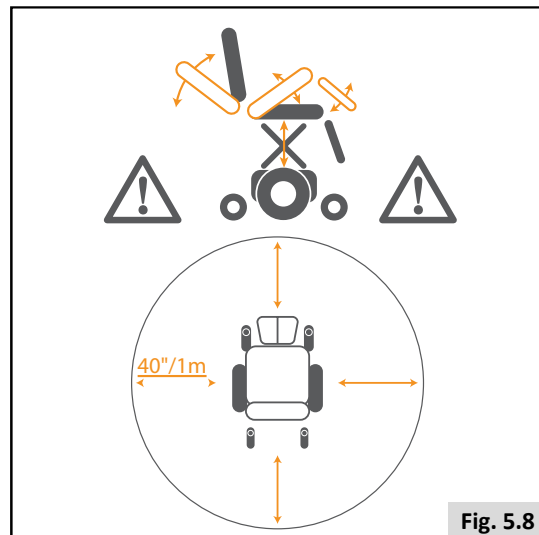

5.4 Preset seat depth, (Fig. 5.12)

CAUTION!

When a bigger seat depth is required ensure that the cables are lengthened before the mechanical adjustment takes place.

DANGER!

We strongly recommend that you contact your Sunrise Medical approved authorized dealer to adjust the seat depth, because adjusting the seat depth will affect the center of gravity.

5.4.1 Sedeo® Ergo (Standard), (Fig. 5.12)

- Use a 5.0 mm Allen Key, (Hex Wrench).
- Loosen the 2 screws, (A), on the bottom of the outer seat plate, but do not take the screws out as these prevent the shift pieces from pulling out.
- The back assembly can now be shifted backwards or forwards to adjust the seat depth.
- Tighten the screws.

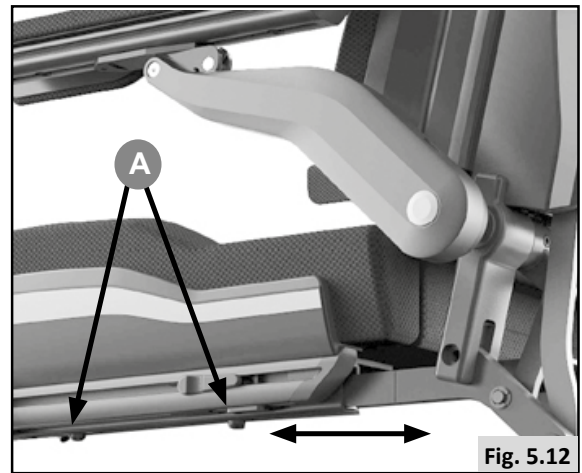

5.5 Pre-set headrest

- The headrest height is changed by pushing the set stop and sliding the headrest to the desired height (Fig. 5.13).
- The headrest forward and back position, height and angle can all be adjusted by loosening the hinge bolts (A) with a 5mm Allen key. Move the headrest to the desired position and tighten the bolts securely (Fig. 5.14).
- To adjust the horizontal position, loosen the screws at the headrest upholstery, position the headrest as required and tighten the screws securely.

DANGER!

- If a headrest is part of the options selected for the user/ chair, never drive the chair without the headrest attached.
- Never use the chair without a headrest if a person is transported with the chair in a vehicle.

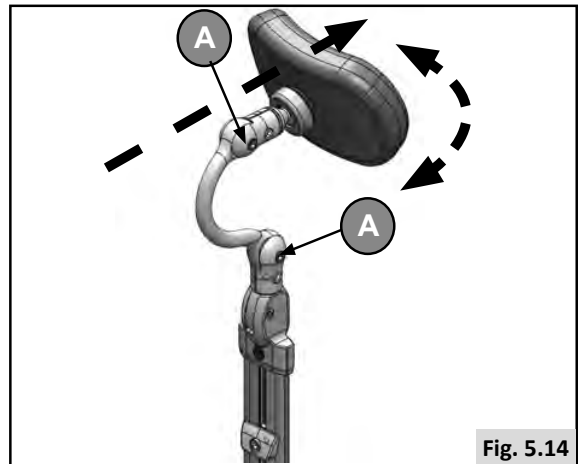
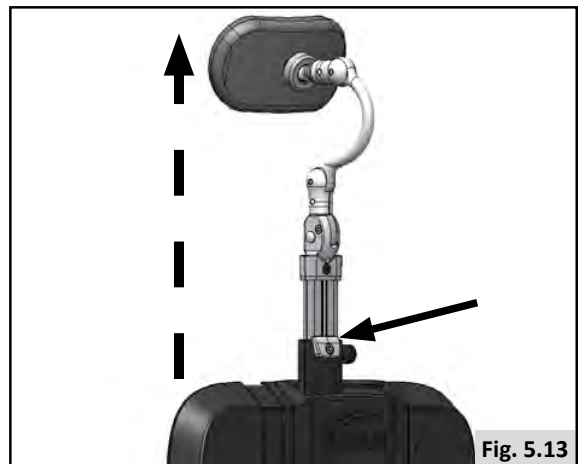

5.6 Swing-away controller bracket

The joystick can be mounted with a mechanism that allows the joystick to be locked in a forward or retracted position, and can accommodate a mid-line mount so the joystick can be located in the center of the wheelchair.

Swing-away (Fig.5.15).

- To Swing-away the joystick, push outward on the inside of joystick.
- Push the joystick away from the front of the armrest until it locks into the outside swing-away position.
- To return to forward position, push the back of the joystick, forward until it locks into place.
- To Swing-away the joystick to the inside, push inward on the outside of joystick.
- Push the joystick away from the front of the armrest until it locks into the inside swing-away position.
- To return to forward position, push the back of the joystick, forward until it locks into place.

Pre-setting depth of the controller (Fig. 5.16)

1. Loosen screws (A).
2. Slide controller (B) to desired position.
3. Tighten screws (A).

There are 2 ways to pre-set the height of the controller.

Pre-setting height of the controller (1) (Fig 5.17)

1. Loosen screw (A).
2. Slide controller (B) to desired height.
3. Tighten screws (A).

Pre-setting height of the controller (2) (Fig 5.18)

1. Loosen screw (C).
2. Slide controller (D) to desired height.
3. Tighten screw (C).

5.7 Check after setup and/or adjustment of wheelchair

After the initial setup by the Sunrise Medical Authorized Dealer or after making any adjustments to the wheelchair a check to confirm that no interferences exist must be completed.

Interferences can happen (but not limited to) adjustment's to the joystick, armrest, specialty control mounts, leg rest, headrest, etc. After an adjustment has been made, the movement of that device may collide or hinder the operation of another component of the wheelchair. A check must be performed prior to operation of the chair to make sure all moving pieces move freely and through the entire range of motion without coming into contact with another part of the wheelchair.

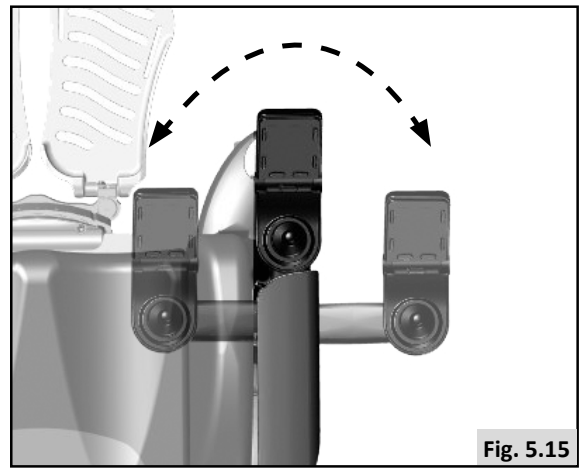

Fig. 5.15

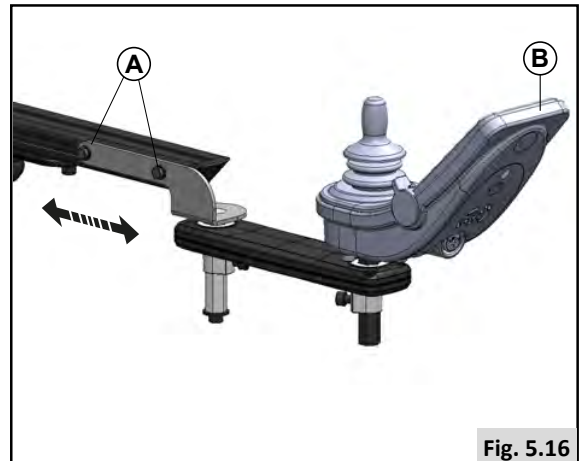

Fig. 5.16

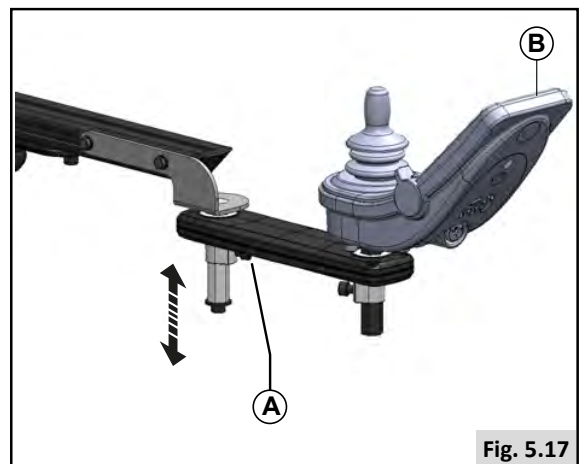

Fig. 5.17

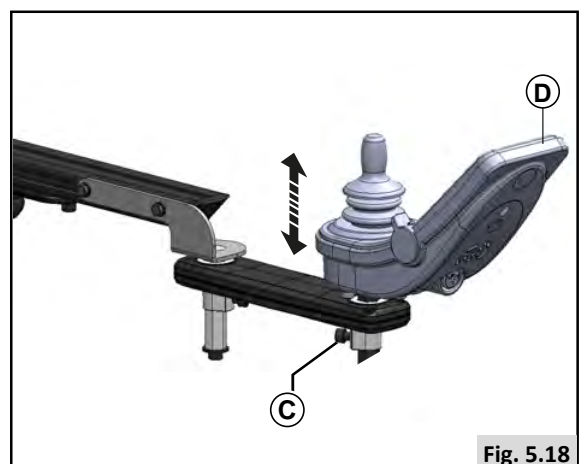

Fig. 5.18

6.0 Seating positioning accessories

6.1 Lap strap / seating positioning belt (Fig. 6.1).

DANGER!

- This product is only to be used to position a single person in a wheelchair.
- Lap straps are not suitable for transit purposes, approved occupant restraint systems must be used.
- Failure to heed these warnings may result in severe injury or death.
- Ensure that the carer or attendant is trained in the correct operation of the belts.
- Untrained carers or attendants may lead to delays, if an emergency situation occurs.

Mounting a lap strap / seating positioning belt

Feed the bracket ends of the straps under the backrest brace bar as shown, using the lower fixing hole. Ensure that the adjuster buckles can be accessed and the strap is not twisted (A-Fig. 6.2).

- Put a washer on the bolt.
- Pass the bolt through the lap strap fixing bracket.
- Put the next washer on to the bolt, (Fig. 6.3).
- Screw the bolt into the lowest pre-drilled hole in the frame (B-Fig.6.2).
- Tighten using a 5.0mm hex wrench to a torque value of 60-70 in-lbs (6.8-7.9 Nm) (C-Fig.6.2).
- Adjust the lap strap to suit, leaving no more than a hand's width gap for comfort and safety.
- The hand clearance should be with the lap strap under normal tension and not allow large gaps or loops (Fig. 6.5).
- Generally, the lap strap should be fixed so that the straps sit at an angle of approximately 45° (Fig. 6.6) and when correctly adjusted should not allow user to slip down in the seat (Fig.6.7).
- Place the strap loosely across the seat with the opening end of the buckle facing to the right for a left handed person and to the left for a right-handed person. Pass the other ends of the strap through the gap between the backrest posts and the backrest (Fig. 6.4).

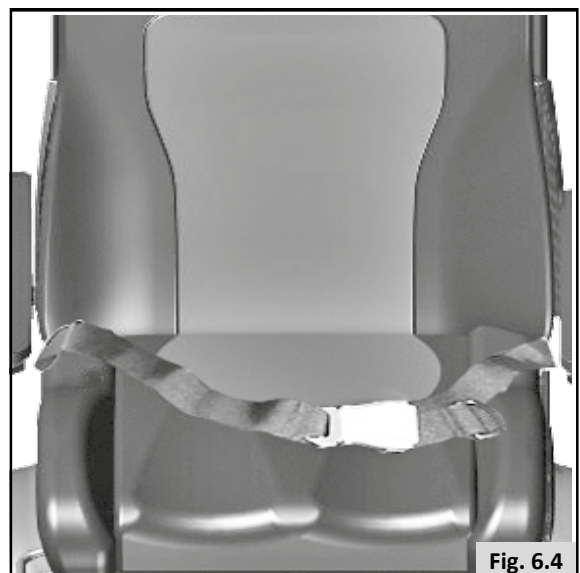
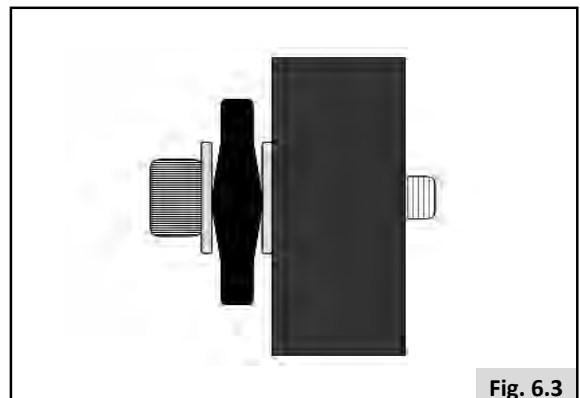
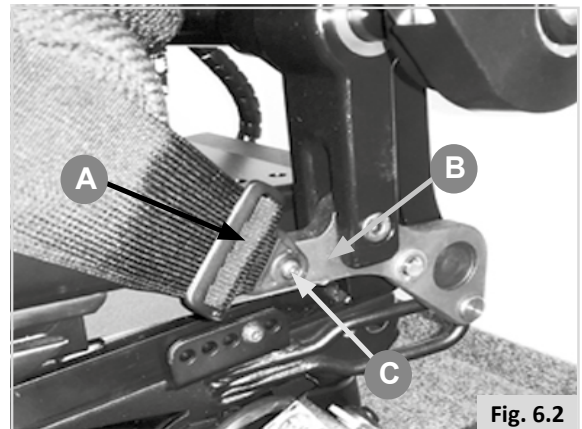

Positioning a person with a lapstrap

DANGER!

- Always make sure that the lap strap is correctly secured and adjusted prior to use.
- Too loose a strap could cause the user to slip down and cause serious injury.
- Check lap strap and securing components at regular intervals for any signs of fray or damage. Replace if necessary.
- When servicing, check for correct operation of the release buckle and for any signs of wear on the material or plastic brackets.
- Regular Checks/Activities:
- As with all positioning components, there is a need for corrective adjustments as the person changes their seating position over time.
- Check the belts regularly for correct fit, to ensure the safety and comfort of the user.

NOTE-

- Standard Sling - Lap strap movement is restricted by upholstery
- Contoured back - Use universal bottom bracket as per recline back method.

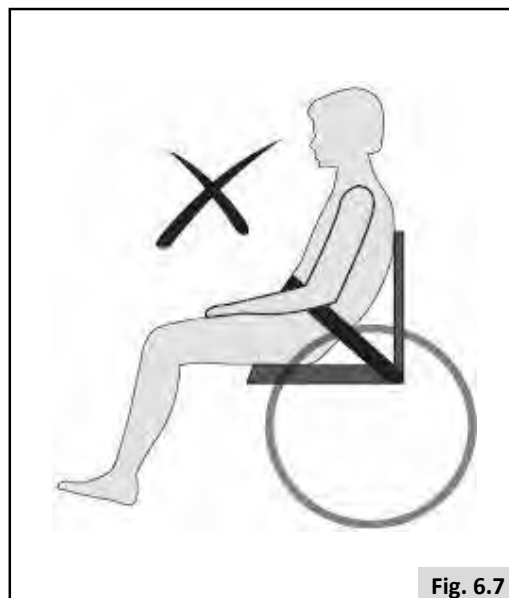
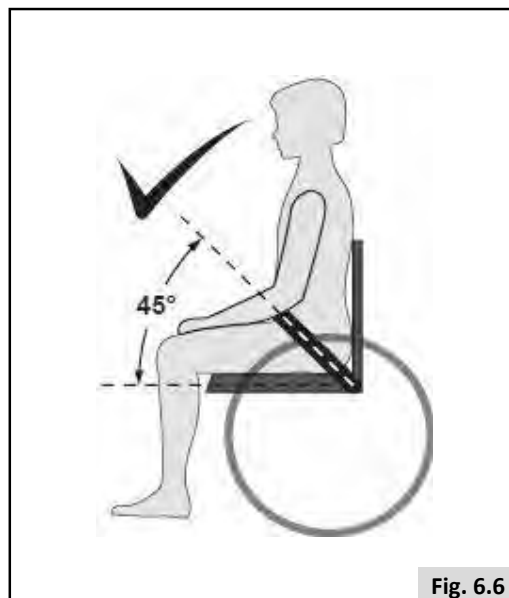

7.0 Using the seating system

7.1 Getting in and out of the wheelchair (Transferring)

Sunrise Medical recommend that you consult your healthcare professional for assistance in developing your personal front or side transfer technique to best suit your needs and avoid any personal injury.

DANGER!

To prevent a fall:

- Ensure controller is switched off during transfers to avoid unintentional movement. If you fail to do so you may touch the joystick and cause your system to move when you do not expect it.
- Ensure that the free wheel switch has been set to 'drive',  General manual.
- Rotate the front casters so that they point forward.
- Work with your health care professional to learn all safe methods for transfers.
- Make sure motor brakes are engaged. This keeps the system from moving when you transfer.
- It is dangerous to transfer on your own. It requires good balance and agility. Be aware that there is a point during every transfer when the seating system seat is not below you.
- Learn how to position your body and how to support yourself during a transfer.
- Have someone help you until you are sure you can do a safe transfer on your own.
- Do not stand on the footrest. Putting your full weight on the footrest may lead to wheelchair damage and to hazardous situations, including the wheelchair tipping up.
- Make sure your feet do not "hang up" or get caught in the space between the footrests.

Preparing for forward transfer (Center Mount Legrest)

Preparing the center mount legrest (Fig. 7.1)

DANGER!

Move your wheelchair as close as possible to the seat you intend to transfer into.

- Flip up (A) and (B) so they are out of the way.

Lower the center mount foot plate (if fitted), Controller:

- Ensure the area is level and free of obstacles and hazards.
- Turn the control system ON.
- Select the powered center mount leg rest.
- Push the joystick forward until the foot plates rest fully on the ground (Fig. 7.2).
- Switch the control system OFF before transferring.

WARNING!

Be aware that when powered, the area around and underneath the footplate needs to be clear of all personal items and bodily extremities to prevent injury or damage to property.

CAUTION!

Once the leg rest is fully lifted or in its lowest position do not hold the joystick in its operating position as this could damage the actuator.

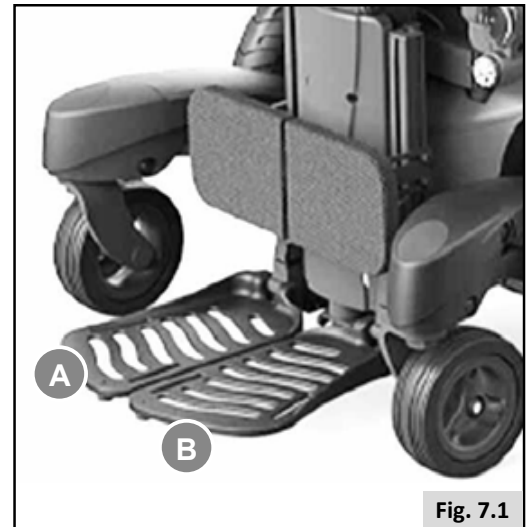

Fig. 7.1

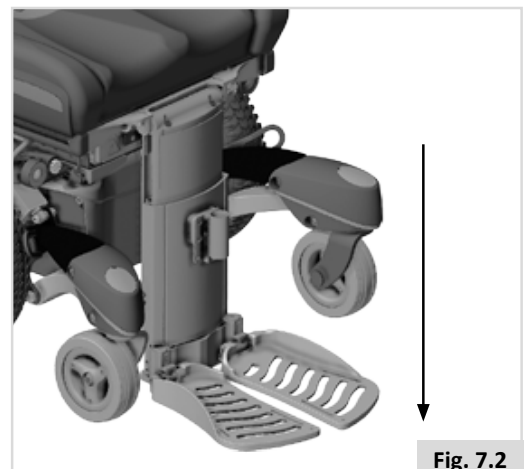

Fig. 7.2

Preparing for side transfer:



- Move your system as close as you can to the seat you are transferring to. If possible, use a transfer board.
- Transfer as far back onto the seat surface as you can. This will reduce the risk that you will miss the seat or fall.

Flip up armrest

- On the side you wish to transfer from; flip the armrest all the way up until it goes into its mechanical stop. This frees your space for side transfer (Fig. 7.3).

Remove side cushion (Bolster)

- To remove the side cushion, pull the plastic lever attached to the aluminum seat side rails backwards (Fig.7.4 - A).
- Swing the back part of the cushion outwards to an angle of approximately 10° (Fig 7.5).
- Lift the cushion out from the front pin.



Fig. 7.3



Fig. 7.4



Fig. 7.5

7.2 (Powered) seating option

The wheelchair can be equipped with the following powered options to adjust your seating position. These options can be operated by the user without the use of tools.

Powered adjustable seating options (Fig. 7.6 - 7.8)

How to operate these powered seating options can be found in:

📖 CONTROLLER.

1. Powered tilt function
2. Powered seat lift
3. Powered backrest recline
4. Powered elevating legrests

⚠️ DANGER!

- Use of the powered adjustable seating options may influence the stability of the wheelchair.
- Only use the powered adjustable seating options when the wheelchair is on a flat surface! Do Not attempt to operate any power seating option while positioned on an incline.
- Please stay clear of any powered actuator while the component is in motion. Sunrise power mechanisms move over large ranges of travel. Users should be aware of their surroundings while components are in motion.
- While driving this seating system in the reclined, elevated, or tilted position use caution.
- Do Not attempt to operate any power seating option while this seating system is in motion.
- Do not attempt to operate the lift or tilt power seating options around children.
- Through programming it is possible to reverse the direction of all powered seating functions, ensure you know which direction your seat is going to move before operating.
- Please be aware that the lift/tilt modules present a trap hazard. Make sure that during operation the lift/tilt modules are free from all clothing, hands, feet and other extremities, to prevent injury.
- Do not drive on ramps or slopes with the seating in the elevated position. Before attempting to climb or descend a slope, return the wheelchair to a standard seated drive position, with the backrest upright.

This power system is designed to automatically reduce the maximum driving speed to a creep mode when certain power seating limits are reached. Depending on the configuration of the chair there might be multiple creep speeds.

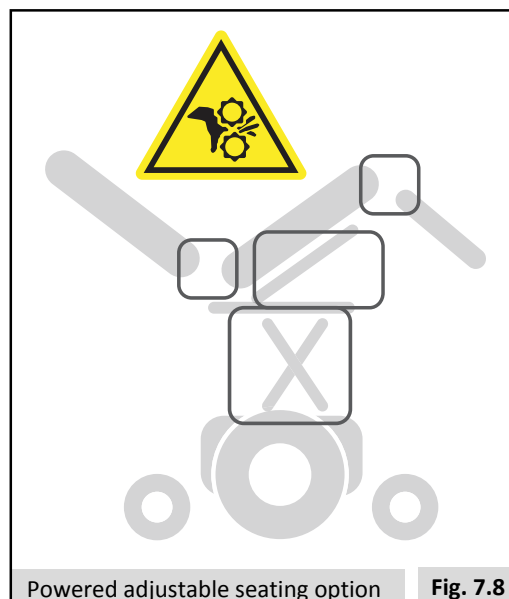
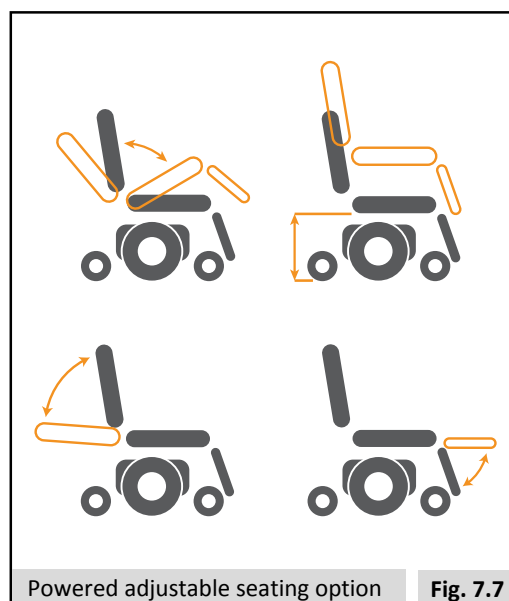
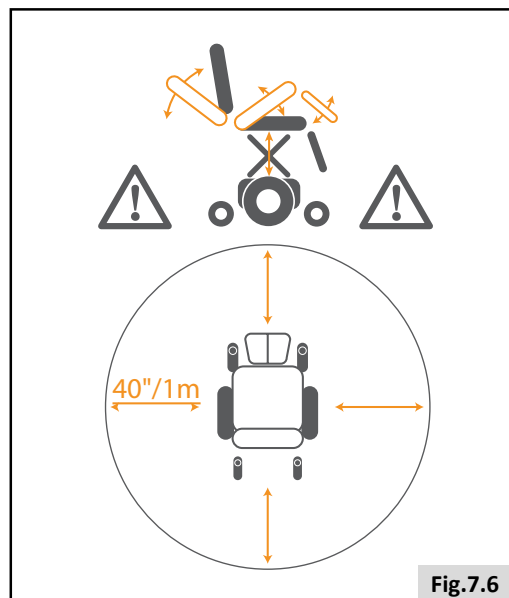

7.3 Electric Seating function

The Quickie Q700 M has an electric seating function. This function is the seat position to which all the Memory seat positions described above come back to by pulling the Joystick into the backward direction when in the seating memory mode.



When the supine function is used, the center of gravity is moved away from the original safe position into a raised or retracted position. This can increase the likelihood of tipping over. So only use this seat function on a level floor and drive in the lowest speed. Not doing so could lead to personal injury.

7.4 Seat Memory Position

The control system on the Q700 M has up to 6 predefined seat memory positions. Each ordered memory location has a set of factory seat positioning presets:

1. Seated
2. Supine
3. Pressure Relief
4. Feet Above Heart
5. Transfer
6. C-ME®

The Seat actuators are all working with a feedback system to track their positions and movements.

This is important:

- a. to reach the required memory position.
- b. to prevent mechanical clashes of the seat.
- c. to operate the actuators especially towards the memory positions in an ergonomic, smooth and safe way.

All ordered memory positions, if not suitable for the user, can be changed and modified to the needs required. The software takes into account the range of the available mechanical movements and also all safety aspects.

7.5 Retrieving a Memory Seat Position

(Fig.7.9 to 7.11)

1. Press the "Mode" button, (A), one or more times until a seat icon appears in the LCD control panel display.
2. Move the joystick to the left or right to select a memory seat position (Seating, Supine, Pressure Relief, Feet Above Heart, Transfer, or C-ME®). A seat icon and the memory description for the relevant position are shown in the LCD control panel display.
3. Move and hold the joystick forwards. The seat adjusts to the factory preset position. The movement can be stopped at any time and started again when moving the Joystick forward.
4. In any of the 6 Memory seat position moving the Joystick backwards brings the seat into the "Seating" memory position. Once the seat has adjusted to the saved position, it stops moving.

NOTE!

- Movement of the seat can be stopped at any time by releasing the joystick.
- During a stop period, another memory position can be selected with a right or left movement of the Joystick. After selecting a new Memory position, moving the joystick forward will operate the seat into the new selected position.

7.6 Return to drive mode

Press the "Mode" button one or more times until a standard display image with speed indicator appears in the LCD control panel display.

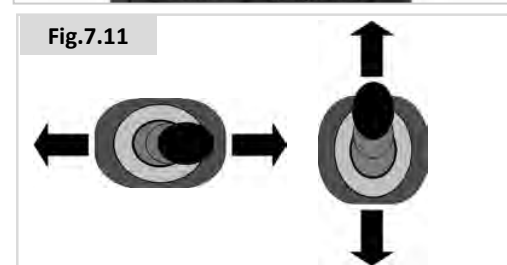
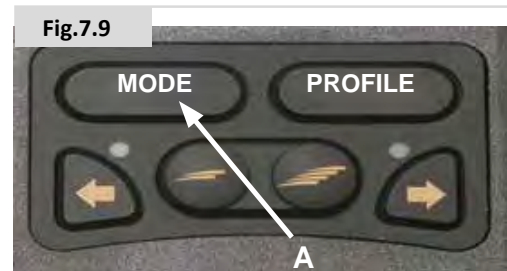

7.7 Saving a new position to memory

1. Remove the rear cover of the backrest and connect a Switch with a 3.5mm Jack to the socket on the CxSM (Fig. 7.12).
2. Press the "Mode" button one or more times until a seat icon appears in the LCD control panel display (Fig. 7.13).
3. Move the joystick to the left or right to select a memory seat position (Seating, Supine, Pressure Relief, Feet Above Heart, Transfer, or C-ME®) (Fig. 7.14). A seat icon and the memory description for the relevant position are shown in the LCD control panel display (Fig. 7.13).
4. Move and hold the joystick forwards (Fig. 7.14). The seat adjusts to the factory preset position. The movement can be stopped at any time and started again when moving the Joystick forward.
5. Stop the seat movement where required and select with a left or right Joystick movement the seat actuator that needs to be changed.
6. Move the joystick forward or backwards until the required position is reached. Select other actuators if required and move them where need.
7. Move the Joystick left or right until the factory Memory position is reached and where the new position shall be programmed in.
8. Press and hold the Switch connected to the CxSM (Fig. 7.15) and pull the joystick backwards for 3 seconds until a beep can be heard.
9. Release the Joystick and the button. Your new required position is now stored and the actuators will stop always in this new programmed end position.

7.8 Delete programmed memory

positions Refer to Fig. 7.12 to 7.15

1. Remove the rear cover (A) of the backrest and connect a Switch with a 3.5mm Jack to the socket on the CxSM, (Complex Seating Module) (Fig. 7.12).
2. Press the "Mode" button one or more times until a seat icon appears in the LCD control panel display (Fig. 7.13).
3. Move the joystick to the left or right to select a memory seat position (Seated, Pressure Relief, Supine, Feet Above Heart, Transfer, or C-ME®) (Fig. 7.14). A seat icon and the memory description for the relevant position are shown in the LCD control panel display (Fig. 7.13).
4. Press and hold the Switch connected to the CxSM (Fig. 7.15) and pull the joystick backwards for 6 seconds. After 3 seconds you will hear the programming beep and after 6 seconds you will hear a change in the beep sound.
5. As soon as you hear this new sound release the Joystick and the button. All memory positions are now set to the factory settings.

7.9 Return to drive mode

Press the "Mode" button one or more times until a standard display image with speed indicator appears in the LCD control panel display.

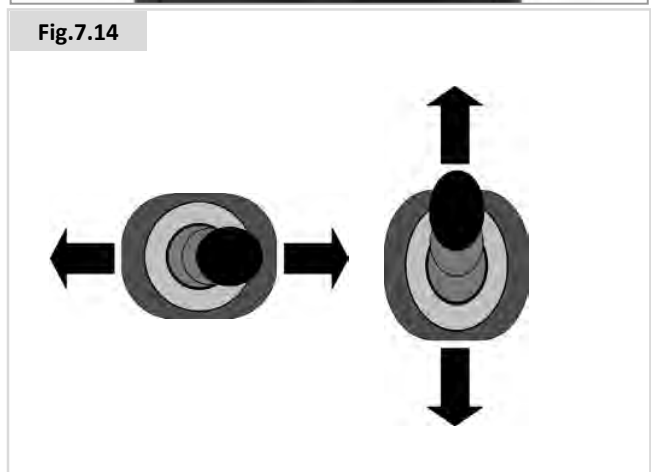
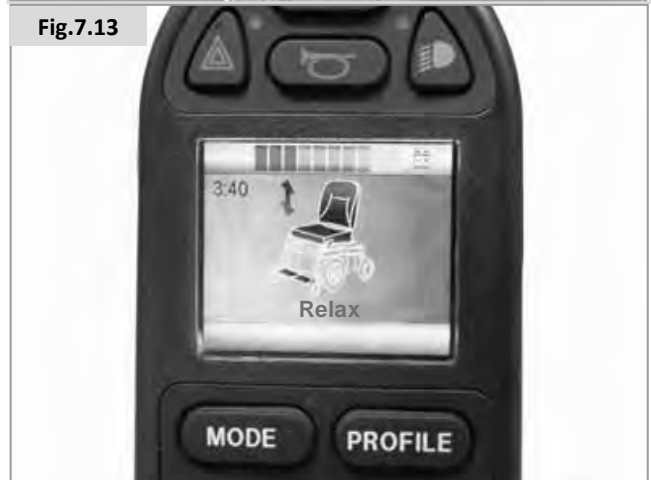
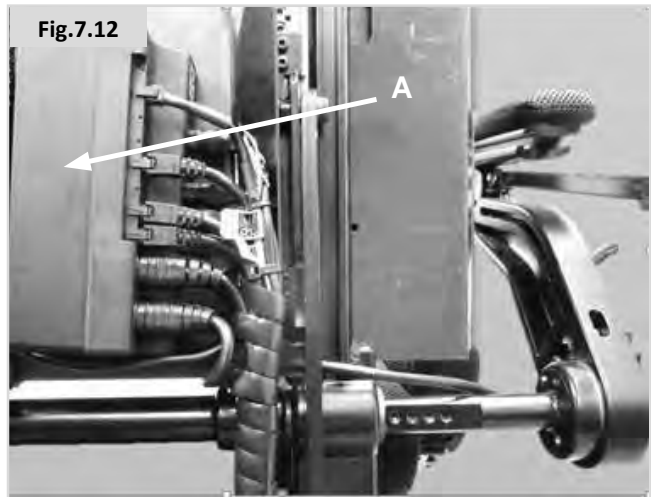

8.0 Maintenance and cleaning

The wheelchair's lifespan is dependent on it being well maintained.

For information concerning specific settings, maintenance or repair work, please contact your authorized Sunrise dealer.

Always be sure to mention the model and year of manufacture and identification number provided on the identification plate of the wheelchair when contacting your authorized dealer.

CAUTION!

The wheelchair should be serviced by your authorized Sunrise dealer once a year or, in the case of intensive use, every six months. For a list of approved authorized dealers in your area please contact Sunrise Medical Service Center.

The contact details of your local Sunrise Medical Service Center can be found on the inside front cover of this booklet. National and International website addresses are on the back cover.

8.1 General maintenance

- All fasteners should be checked quarterly for wear, such as loose bolts or broken components.
- Loose fasteners should be re-tightened according to the installation instructions.
- Check all straps monthly for fraying, ripped seams or other indications of excessive wear damage. Discontinue use if damage is found.
- Chest straps should be replaced at the first indication of damage and/or excessive wear.
- If a broken or loose component is found, discontinue use immediately and contact your authorized Sunrise Medical dealer for replacement.
- Check all Velcro® fastening straps for correct adhesion when pressed together.
- Ensure that any contamination, such as fluff, hair, etc is removed from the Velcro® straps. Such contamination may affect adhesion.

Daily checks

Perform the daily check routine before driving as described below.

Checking seating

- Ensure that all the cushions are in place.
- Make sure that the backrest is correctly fitted and adjusted.
- Visually inspect the wheelchair to make sure the leg rests, armrests etc. are correctly positioned and attached to the wheelchair and all fasteners are sufficiently tightened.
- Ensure that the seat interface knobs are tight and secure.

Checking clothing on potential entrapment

- When operating the wheelchair, ensure that your clothing does not hamper the wheelchair (i.e. too long). Before use, always make sure your clothing or accessories do not come into contact with the wheels or other moving and/or rotating parts in which they could become entangled.

Weekly checks

Perform the weekly check routine before driving as described below.

Checking connectors and cables

- Make sure that all connectors are securely mated.
- Check the condition of all cables and connectors for damage.

Checking controller

- Check the thin rubber gaiter or boot around the base of the joystick shaft for damage or splitting. Check visually only, do not handle the gaiter.
- Make sure that all components of the control system are securely mounted.

Checking controls

- Switch on the hand control – Do the lights flash? This signifies that there is a fault in the electronic system. Refer to section 9 for basic troubleshooting.
- Operate all of the electric options, including lights and indicators, (if fitted), to make sure that they work correctly.
- Drive the wheelchair in each of the drive profiles to make sure the wheelchair performs as it did before.

General weekly checks

- Check tires for proper inflation level (if applicable).
- Check frame and base for foreign objects and/or obstructions.
- Ensure the knobs that attach the seat frame to the front of the base are not loose.

Quarterly checks

Perform the quarterly check routine before driving as described below.

- Check all straps for fraying, ripped seams or other indications of excessive wear damage. Discontinue use if damage is found and contact a Sunrise Medical Authorized dealer.
- Check chair for any missing or loose nuts, bolts, and /or fasteners. Contact a Sunrise Medical Authorized dealer if found.
- Check wheelchair for any broken components, unusual wear, or other indicators of excessive wear. Discontinue use if damage is found and contact a Sunrise Medical Authorized dealer.

WARNING!

- If you are in any doubt about the performance requirements of your wheelchair contact your Sunrise Medical authorized dealer.
- After performing any maintenance or repairs on the wheelchair you must make sure that it is functioning correctly before it is used.
- A complete inspection, safety check and service should be made by a Sunrise Medical authorized dealer at least once per year.
- All fasteners must be replaced like for like using the correct length, tensile strength and materials.
- When replacing self-locking nuts, or nuts/studs secured with a thread locking solution, ensure that a suitable thread locking solution is reapplied to the fastener.
- Check all Velcro® fastening straps for correct adhesion when pressed together.
- Ensure that any contamination, such as fluff, hair, etc is removed from the Velcro® straps. Such contamination may affect adhesion.
- Do not reuse fasteners.

8.2 Cleaning your seating system

The wheelchair should be wiped over once per week with a slightly damp, not wet, cloth and any fluff or dust that has accumulated around the actuators should be blown or dusted away.

CAUTION!

Make sure that you dry all parts of your wheelchair if it becomes wet or damp after cleaning or if it is used in a wet or damp atmosphere.

DANGER!

It is important that should the wheelchair be used by more than one person it is cleaned thoroughly to ensure there is no cross infection.

8.2.1 Cleaning and inspection of your seating

WARNING!

Tears, dents, wearing, or slackening of upholstery particularly near to metal could result in poor posture or lower levels of comfort and pressure relief.

Cleaning instructions for seating

You can wash all parts of the covers with a gentle-wash detergent at 100°F (38°C). You can spin-dry the covers, but do not dry them in a dryer. You can remove all parts of the covers independently of each other and wash them separately. Take out the foam inlays prior to washing and close the Velcro® fasteners!

Where upholstery cannot be removed, clean regularly to prevent build up or soiling. Clean with a damp soapy cloth however disinfectants may be used in dilution as specified by their manufacturer. Ensure surfaces are rinsed well with clean water and dried thoroughly.

8.3 Hygiene measures when being re-used:

Prior to the wheelchair being re-used, it must be carefully prepared. All surfaces which come into contact with the user must be treated with a disinfection spray. To do this, you must use a suitable disinfectant for rapid alcohol-based disinfection of medical products and medical devices. Please take into account the manufacturer's instructions or the disinfectant you are using.

CAUTION!

- Do not use solvents, bleaches, abrasives, synthetic detergents, wax polishes or aerosols.
- Disinfectants may be used in dilution as specified by the manufacturer.
- Ensure surfaces are rinsed with clean water and dried thoroughly.

8.4 General cleaning instructions

CAUTION!

- You should remove stains on your seat as soon as possible.
- After a long period of use, you should clean the cover of your seat with a standard commercially available dry foam cleaning agent.
- You should always clean the whole surface and not just individual spots in order to avoid unattractive edges. The longer you wait the more difficult it will be to remove them.
- Avoid powerful rubbing with aqueous solutions. This will roughen up cover fabric.
- Dirt stains (eg. beer, blood, cola, red wine, etc) are best removed with the dry foam cleaning agents or with a mild action detergent.
- Please follow the respective instructions or use when treating the covers.
- The covers should be allowed to dry for at least 48 hours after cleaning with foam cleaning agents.
- Grease stains (eg. ballpoint pen, lipstick, chewing gum, etc). Use a proprietary stain remover. Carefully rub the soiled location on the surface only with a clean cloth impregnated with the stain remover.
- Use only a very small quantity of stain remover.
- Test a small inconspicuous area first.
- The upholstery material must not be saturated, since the stain remover might then attack it and destroy it.
- Do not use a hose or a pressure washer to clean your chair.

WARNING!

- Always read the label on any commercial or domestic cleaning substances.
- Always follow the instructions carefully.

8.5 Cleaning Accessories:

- All parts/ accessories such as swing away trays should be cleaned with a damp cloth.
- All lateral supports, headrest, armrests, side- guards, calf pads, lap belts and knee pads should be cleaned with a damp cloth.

Cleaning controls:

Should the control of your wheelchair become soiled or dirty, it can be wiped with a damp cloth with a dilute disinfectant until clean.

DANGER!

- This is important should the wheelchair be used by more than one person to ensure there is no cross infection
- Ensure that wafer boards, joysticks (all variants), head arrays and switches (all variants) are cleaned with a mild disinfectant and a cleaning cloth to avoid any cross infection possibilities. Following removal from chair regularly wash the sip and puff mouth piece and tube to maintain cleanliness and functionality.
- Ensure control is switched off before cleaning.

8.6 Storage

To keep the upholstery and other parts of the wheelchair in good condition, store in a dry environment as close to room temperature as possible.

CAUTION!

- Never store your wheelchair in direct sunlight or in a damp/outdoor environment.
- Direct sunlight might bleach upholstery / plastic parts and cause metal parts to become hot.

Maintenance and Inspection Schedule	To be performed by:			
	End user / caregiver			Sunrise Medical Authorized dealer
	Daily*	Weekly	Quarterly*	Annually
Daily check routine as described in Section 8.1, Page 26	*			
Weekly check routine as described in Section 8.1, Page 26		*		
Clean wheelchair upholstery  Seating system		*		
Quarterly check routine as described in Section 8.1, Page 26			*	
Complete inspection, safety check and service should be made by a Sunrise Medical authorized dealer				*

* Daily = Before each use of the wheelchair. Quarterly = Every three (3) months.

If fasteners are found to be loose a Sunrise Medical Authorized Dealer should tighten the fastener to the torque setting per size detailed below, unless stated otherwise in all appropriate owner's manuals or installation instructions (if applicable).

- M8 Fasteners = 120-132 IN-LBS (13.5-14.9 N-m).
- M6 Fasteners = 60-70 IN-LBS (6.8-7.9 N-m).
- M5 Fasteners = 27-32 IN-LBS (3.1-3.6 N-m).
- M4 Fasteners = 6-8 IN-LBS (0.7-0.9 N-m).

9.0 Technical specifications:

9.1 Applicable norms / standards



This product complies with the regulations and guidelines for medical aids and carries a CE symbol. The product meets the requirements and standards below. These are checked by independent institution

Standard	Definition / description	Test Dummy Weight
EU guideline 93/42 EEC	Applicable as mentioned in Appendix	N/A
NEN-EN 12182:2014 Class B	“The requirements from EN12182 (2014) as mentioned in NEN-EN 12184 (2014): Assistive products for persons with disability - General requirements and test methods”	Q700 M Ergo
	Q 700 M	350 lbs / 160 kg
NEN-EN 12184:2014 Class B	Electrically powered wheelchairs, scooters and their chargers - Requirements and test methods	Q700 M Ergo
	Q 700 M	350 lbs / 160 kg
ISO 7176-8:2014	Requirements and test methods for impact, static and fatigue strengths July 1998	N/A
ISO 7176-9:2009	Climate tests for electric wheelchairs	N/A
ISO 7176-14:2008	Requirements and test methods for control systems for electric wheelchairs 1997	N/A
ISO 7176-16:2012	Requirements for resistance to ignition of upholstered parts May 1997	N/A
ISO 7176-19:2008	Wheelchairs - Part 19: Wheeled mobility devices for use as seats in motor vehicles: The Q-series meet the crash test requirements as described in ISO 7176-19	Q700 M Ergo
	Q 700 M	165 lbs / 75 kg
ISO 7176-4:2008	Wheelchair Energy Consumption Theoretical Range	Q700 M Ergo
	Q 700 M	230 lbs / 104 kg
ANSI/RESNA WC-1:2009	Requirements and test methods for wheelchairs (including scooters) 2009	N/A

10.0 Guarantee / Warranty

THIS GUARANTEE DOES NOT AFFECT YOUR LEGAL RIGHTS IN ANY WAY.

Sunrise Medical* provides a guarantee, as set out in the warranty conditions, for wheelchairs to its customers covering the following.

Warranty conditions

1. **FOR FIVE (5) YEARS** - Sunrise warrants the frame of this wheelchair against defects in materials and workmanship for five years from date of first consumer purchase.
2. **FOR ONE (1) YEAR** - We warrant all Sunrise-made parts and components of this wheelchair including: motors, gearboxes, and electronic components, against defects in materials and workmanship for one year from the date of first consumer purchase.
3. **FOR SIX (6) MONTHS** - We warrant batteries for 6 months from the date of first consumer purchase.
4. **LIMITATIONS** -
 1. We do not warrant:
 - a. Tires and tubes, upholstery, pads, and push handle grips.
 - b. Damage from neglect, accident, misuse, or from improper installation or repair.
 - c. Products modified without Sunrise Medical's express written consent.
 - d. Damage from exceeding the weight limit.
 2. This warranty is VOID if the original chair serial number tag is removed or altered.
 3. This warranty applies in the USA and Canada only. Check with your authorized dealer to find out if international warranties apply.
 4. This warranty is not transferable and only applies to the first consumer purchase of this wheelchair through an authorized Sunrise Medical dealer.
5. **WHAT WE WILL DO** - Our sole liability is to repair or replace covered parts. This is the exclusive remedy for consequential damages.
6. **WHAT AUTHORIZED DEALER MUST DO** -
 1. Obtain from Sunrise Medical, while this warranty is in effect, prior approval for return or repair of covered parts. Contact Customer Service for a Returned Material Authorization (RMA) number and information as to where to return the product. Upon contacting Customer Service please provide Model number, Serial number, description of what is required for service/repair, and any additional information as to reason for service being performed to the wheelchair.
7. **NOTICE TO CONSUMER** -
 1. You must pay the cost of labor to repair, remove or install parts even if they are covered under warranty.
 2. If allowed by law, this warranty is in place of any other warranty (written or oral, express or implied, including a warranty of merchantability, or fitness for a particular purpose).
 3. This warranty gives you certain legal rights. You may also have other rights that vary from state to state or province to province.
8. This guarantee is subject to the law of the country in which the product was purchased from Sunrise Medical

* Denotes the Sunrise Medical facility from which the product was purchased.

Additional Notes For Australia Only:

- i. For goods provided by Sunrise Medical Pty Ltd in Australia, our goods come with a guarantee by Sunrise Medical that cannot be excluded under Australian Consumer Law.
- ii. You are entitled to a replacement or refund for a major failure and for compensation for any foreseeable loss or damage.
- iii. You are also entitled to have the goods repaired or replaced if the goods fail to be of acceptable quality and the failure does not amount to a major failure.
- iv. The benefits to you given by this warranty are in addition to your other rights and remedies under a law in relation to the goods to which the warranty relates.

Record your serial number here for future reference:



Website Addresses:

US = www.SunriseMedical.com

FR = www.SunriseMedical.fr

ES = www.SunriseMedical.es



Customer Service 800.333.4000
In Canada 800.263-3390

Sunrise Medical
2842 N. Business Park Ave.
Fresno, CA 93727 • USA

©2018 Sunrise Medical (US) LLC
4.18 247554 Rev. A