

zippie®

VOYAGE

Zippie® VOYAGE

- with transit option without transit option

Dealer: This manual must be given to the user of this wheelchair.

User: Before using this wheelchair read this entire manual and save for future reference.



Owner's Manual

Zippie® VOYAGE

- con opción de tránsito sin opción de tránsito

Distribuidor: Este manual debe ser entregado al pasajero de esta silla de ruedas.

Pasajero: Antes de usar esta silla de ruedas, lea este manual en su totalidad y guárdelo para futura referencia.

Cada una de las sillas se envía con un manual de instrucciones en inglés. El manual en español está disponible en formato PDF en nuestra página en Internet: www.SunriseMedical.com. Ingrese a la página del producto específico para descargar el manual, o comuníquese con el proveedor autorizado de Sunrise Medical.

Manual de Instrucciones

Zippie® VOYAGE

- avec option pour transport sans option pour transport

Au Fournisseur : Ce manuel doit être remis à l'utilisateur de ce fauteuil roulant.

À l'Usager : Veuillez lire tout le manuel et le conserver pour référence ultérieure.

Chaque fauteuil est livré avec un manuel d'instructions en anglais. La version en français est à votre disposition en format PDF sur le site : www.SunriseMedical.com. Veuillez vous rendre à la page de votre produit pour télécharger le manuel dans la langue souhaitée, ou contactez un fournisseur agréé Sunrise Medical.

Manuel d'instructions



SUNRISE MEDICAL LISTENS

Thank you for choosing a Zippie product. We want to hear your questions or comments. about this manual, the safety and reliability of your chair, and the service you receive from your Sunrise dealer. Please feel free to write or call us at the address and telephone number below:

SUNRISEMEDICAL (US) LLC
 Customer Service Department
 2842 N. Business Park Avenue
 Fresno, CA 93727 USA
 (800) 333-4000

Be sure to return your warranty card, and let us know if you change your address. This will allow us to keep you up to date with information about safety, new products and options to increase your use and enjoyment of the wheelchair. If you lose your warranty card, call or write and we will gladly send you a new one.

You can also register your wheelchair at:
www.sunrisemedical.com/register

FOR ANSWERS TO YOUR QUESTIONS

Your authorized dealer knows your wheelchair best, and can answer most of your questions about chair safety, use and maintenance.

For future reference, please fill in the following:

Dealer: _____

Address: _____

Telephone: _____

Serial #: _____ Date/Purchased: _____

ADDITIONAL INFORMATION YOU SHOULD KNOW

No component of this chair was made with Natural Rubber Latex.



DISPOSAL AND RECYCLING INFORMATION

When this product reaches the end of its life, please take it to an approved collection or recycling point designated by your local or state government. This wheelchair is manufactured using a variety of materials. Your product should not be disposed of as ordinary household waste. You should dispose of your wheelchair properly, according to local laws and regulations. Most materials that are used in the construction of this product are fully recyclable. The separate collection and recycling of your product at the time of disposal will help conserve natural resources and ensure that it is disposed in a manner that protects the environment.

Ensure you are the legal owner of the product prior to arranging for the product disposal in accordance with the above recommendations.



www.sunrisemedical.com/register

I. INTRODUCTION	2	VIII. USE & MAINTENANCE.....	12
II. TABLE OF CONTENTS	3	A. Maintenance and Safety Notes.....	12
III. YOUR DEVICE AND ITS PARTS	4,5	B. Cleaning	12
IV. NOTICE– READ BEFORE USE	6	C.Storage Tips	12
A. Choose the Right Device & Safety Options	6	D. Safety Checklist.....	12
B. Review This Manual Often	6	E. Unfolding and Folding Base Frame	13
C. Warnings.....	6	F. Caster Wheels	14
V. GENERAL WARNINGS	6	G. Rear Wheels	14
A. Weight Limit	6	H. Parking Brake Operation	14
B. Intended Use.....	6	I. Seating Installation.....	15
C. Attendants and Caregivers	6	J. Removing the Seating Shell	16
D. Accessories	6	K. Grab Bar.....	16
E. Know your Device	6	L. Tilt in Space Angle Adjustment.....	16
F. Reduce the Risk of an Accident	6	M. Recline Adjustment (optional)	17
G. Safety Checklist	7	N. Knee Angle Adjustment (Advanced)	17
H. Changes and adjustments	7	O. Knee Angle Adjustment (Moderate)	17
I. Environmental conditions	7	P. Canopy Installation and Adjustment.. ..	18
J. Terrain	7	Q. Angle Adjustable Stroller Handle.....	18
K. Street Use	7	IX. DEALER SERVICE & ADJUSTMENT	18
L. Motor vehicle safety	7	A. Positioning and Growth Adjustments.....	18
M. When you Need Help	8	B. Seat Depth Adjustment (Moderate).....	19
N. Choking Hazard	8	C. Seat Depth Adjustment (Advanced).....	19
O. Pinch Points	8	D. Cushion Adjustment (Advanced).....	19
VI. WARNINGS: FALLS & TIP-OVERS	8	E. Adjustable Contour Cushion Adjustments (Adv)	20
A. Center of balance	8	F. Planar Cushion w/o Lateral Supports (Advanced)	20
B. Dressing or changing clothes	8	G. Shoulder Strap Height Adjustment (Advanced).....	20
C. Obstacles	8	H. Back Cushion Height Adjustment (Advanced).....	20
D. Reaching or leaning	8	I. Seat to Back Angle Adjustment (Advanced).....	20
E. Ramps, slopes and sidehills.....	9	J. Back Height Adjustment (Moderate)	21
F. Transfers	9	K. Footrest Adjustments (Advanced)	21
G. Negotiating a curb or single step	9	L. Footrest Adjustments (Moderate)	22
H. Climbing stairs	9	M. Floor to Seat Height Adjustment	22
I. Descending stairs	9	N. Pelvic Positioning Belt Adjustments.....	23
J. Escalators	9	O. Anterior Trunk Butterfly Support.....	23
VII. WARNINGS– COMPONENTS & OPTIONS.....	10	P. Lateral Trunk Supports (Advanced)	24
A. Base Frame	10	Q. Lateral Trunk & Head Supports (Moderate).....	25
B. Upper Extremity Support Tray	10	R. Hip Guides (Moderate)	25
C. Fasteners.....	10	S. Medial Support Pad (Advanced).....	25
D. Footrest.....	10	T. Medial Support Pad (Moderate).....	26
E. Tires and Wheels.....	10	U. Anterior Supports	26
F. Parking Brake	10	V. Head Supports (Advanced).....	26
G. Undercarriage Storage.....	10	W. Tray Arm Height Adjustment.....	27
H. Accessory Trays.....	10	X. Tray Installation and Adjustment.....	27
I. Canopy	10	Y. Shoe Holder Foot Strap Adjustment.....	28
J. Seating Systems	10	Z. Vent/Battery Trays	28
K. Pelvic Positioning Belts.....	10	AA. Front or Rear Add-on Platform.....	28
L. Cushions	10	AB. I.V. Support Pole / O2 Tank Holder	28
M. Tilt and Recline	11	X. SUNRISE LIMITED WARRANTY	29
N. Transit Option and Use.....	11		



1. Folding Base Frame
2. Tray Attachment
3. Rear Transit Hardware (optional)
4. Folding Triggers
5. Rear Tire
6. Quick-release Wheel
7. Undercarriage Storage Basket
8. Front Transit Hardware (optional)
9. Anti-swivel Caster Lock
10. 7" Front Caster Wheel
11. Adjustable Footplate
12. Footrest Adjustment Lever
13. Adjustable Hip Support
14. Grab Handle
15. Adjustable Laterals
16. Adjustable Head Support
17. Moderate Seating Shell
18. Canopy Attachment
19. Push Handle Angle Adjustment
20. Canopy

All features may not be available with some device setups or in conjunction with other device features. Please consult your dealer for more information. Your authorized dealer can also provide you with information on accessories.

ZIPPIE VOYAGE WITH MODERATE SEATING

Adjustment Ranges:

- Tilt**
+5° to -30°
- Recline**
90° to 180°
- Push Handle Height**
32-1/4" to 47-3/4" (82cm-121cm)
- Seat Depth**
8" to 13" (20cm-33cm)
- Seat Width (at hip)**
9.5" to 12" (24cm-30.5cm)
- Backrest Height**
16" to 24" (41cm-61cm)
- Lower Leg /Footrest Adjust Range**
Lower leg/foot:
6" to 12" (15cm-30.5cm)
Footrest angle Adjustment: 50°

Dimensions

- Overall width: 24-1/8" (61cm)
- Floor-to-seat height:
Highest position: 25" (64cm)
Middle position: 23-1/2" (60cm)
Lowest position: 22-1/2" (57.5cm)
- Overall length: 42-1/2" (108cm)
- Overall height: 32-48" (81-122cm)
- Folded length: 35-1/8" (89cm)
- Folded height: 12-1/4" (31cm)
- Max user weight: 75lbs (34kg)
- Turning Circle: 70" (178cm)
- Max slope for park brake: 9°
- Overall weight: 49-1/2lbs (22.5kg)
- Base frame weight: 28lbs (12.7kg)
- Seating weight: 21-1/2lbs (9.8kg)

Voyage Weight Capacities:

NOTE- Individual components should not exceed the weight capacities listed below. The overall combined Maximum load should not exceed 170lbs (77 Kg).

Rider:	75 lbs	34 kg
Undercarriage Storage:	15 lbs	7 kg
Vertical (Rear Mount) Vent:	15 lbs	7 kg
Under Frame Tray:	50 lbs	22.5 kg
Front Mount Platform:	50 lbs	22.5 kg
Rear Accessory Platform	45 lbs	20 kg
Oxygen Tank Holder	10 lbs	4.5 kg
Cup Holder	1 lb	.5 kg



1. Folding Base Frame
2. Folding Triggers
3. Rear Transit Hardware (optional)
4. Rear Tire
5. Quick-release Wheel
6. Undercarriage Storage Basket
7. Front Transit Hardware (optional)
8. Anti-swivel Caster Lock
9. 7" Front Caster Wheel
10. Adjustable Footplate
11. Footrest Adjustment Button
12. Seat Plate
13. Advanced Seating Shell
14. Canopy Attachment Bracket
15. Push Handle Angle Adjustment Button
16. Canopy

All features may not be available with some device setups or in conjunction with other device features. Please consult your dealer for more information. Your authorized dealer can also provide you with information on accessories.

ZIPPIE VOYAGE WITH ADVANCED SEATING

Adjustment Ranges:

Tilt

+5° to -30°

NOTE: When configured in the rearward facing position, maximum posterior (forward) tilt range may be limited.

Recline Advanced

85° to 140°

Push Handle Height

32 1/4" to 47 3/4" (82-121cm)

Seat Depth

5" to 13"

Seat Width (at hip)

6" to 13"

Seat Width (with optional lateral hip supports)

6.5" to 10"

Knee Width

13 1/4"

Knee Width (with optional medial knee supports)

5" - 11"

Headrest Pad Height

13" to 22"

Shoulder Height Adjustment for Belts and Harnesses

Short: 7" to 13"

Tall: 10" -17"

Lower Leg / Footrest Adjustment Range

Lower leg/foot: 1.5" -12"

Footrest angle Adjustment -90° to 100°.

Dimensions

Overall width: 24 1/8" (61cm)

Floor-to-seat height:

Highest position: 26" (66cm)

Middle position: 23 1/2" (60cm)

Lowest position: 22 1/2" (52.5cm)

Overall length: 42 1/2" (108cm)

Overall height:

32-48" (81-122cm) Folded length:

35 1/8" (89cm) Folded height:

12 1/4" (31cm)

Max user weight: 75lbs (34kg)

Turning Circle: 70" (178cm)

Max slope for park brake: 9°

Overall weight: 50lbs (22.7kg)

Base frame weight: 28lbs (12.7kg)

Seating weight: 22lbs (9.8kg)

Seating Options

Standard planar seat with/without hip blocks

Contoured wedge seat with/without hip blocks

Contoured anti-thrust (ledge) seat

Adjustable Contour Seat

Moderate seating

Voyage Weight Capacities:

NOTE - Individual components should not exceed the weight capacities listed below.

The overall combined Maximum load should not exceed 170lbs (77 Kg).

Rider:	75 lbs	34 kg
Undercarriage Storage:	15 lbs	7 kg
Vertical (Rear Mount) Vent:	15 lbs	7 kg
Under Frame Tray:	50 lbs	22.5 kg
Front Mount Platform:	50 lbs	22.5 kg
Rear Accessory Platform	45 lbs	20 kg
Oxygen Tank Holder	10 lbs	4.5 kg
Cup Holder	1 lb	.5 kg

A. CHOOSE THE RIGHT DEVICE & SAFETY OPTIONS

Sunrise provides a choice of many wheelchair styles to meet the needs of your child. However, final selection of the type of device, options, and adjustments rests solely with you and your health care advisor. Choosing the best early intervention device and set-up for safety depends on such things as:

1. The child’s disability, strength, balance, coordination, and the limits of their abilities.
2. The types of hazards that must be overcome in daily use (where you live and work), and other places you are likely to use the device.
3. The dependents need of options for their safety and comfort.

INTENDED USE: The Zippie Voyage is intended for medical purposes to provide mobility to persons under 60lbs(27kg) restricted to a sitting position.

B. REVIEW THIS MANUAL OFTEN

Before using this device you, and each person who may assist you, should read this entire manual and make sure to follow all instructions. Review the warnings often, until they are second nature to you.

C. WARNINGS

The word “**WARNING**” refers to a hazard or unsafe practice that may cause **severe injury or death** to you or to other persons. The “Warnings” are in three main sections, as follows:

1. **V — GENERAL WARNINGS**
Here you will find a safety checklist and a summary of risks you need to be aware of before you ride this device.
2. **VI — WARNINGS — FALLS & TIP-OVERS**
Here you will learn how to avoid a fall or tip-over while performing daily activities with the device.
3. **VII — WARNINGS — FOR SAFE USE**
Here you will learn about practices for the safe use of the device.
4. **VIII — WARNINGS — COMPONENTS & OPTIONS** Here you will learn about the components of the device and options you can select for safety. Consult your authorized dealer and your health care advisor to help you choose the best set-up and options for safe use.

NOTE - Where they apply, you will also find “Warnings” in other sections of this manual. Heed all warnings. If you fail to do so, a fall, tip-over or loss of control may occur and cause severe injury to the rider and/or others.

V. GENERAL WARNINGS

A. WEIGHT LIMIT



NEVER exceed the weight limit of 75lbs (34 kg). Exceeding the weight limit may damage the device, cause a fall, tip-over or loss of control, and cause severe injury to the rider and/or others.

With a Max User Weight of 75lbs (34 kg)



Never hang items greater than 5lbs (2.3kg) from stroller handle or seat back handle. A fall, tip-over, or loss of control may occur.

B. INTENDED USE



Use only for intended medical purposes. Do not use for recreational purposes. Exceeding the weight limit may damage the device, cause a fall, tip-over or loss of control, and cause severe injury to the rider and/or others.

C. ATTENDANTS AND CAREGIVERS



1. Work with the child’s health care professional to learn safety methods best suited to your abilities and those of your child.
2. To prevent injury to your back, use good posture and proper body mechanics when lifting, or tilting your child.
3. Remind the dependent to lean back when you tilt the mobility device backward.
4. When you descend a curb or single step, slowly lower the mobility device in one easy movement.
5. NEVER leave the dependent child alone.
6. When making adjustments to the mobility device, always engage the parking brake and lock caster wheels to help minimize unintended movement.

D. ACCESSORIES



Unauthorized modifications or use of parts, or accessories not supplied or approved by Sunrise Medical may change the chair structure. This will void the warranty and may cause a safety hazard.

Some problems that may occur, but are not limited to:

1. Incorrect Wheels and/or tires that put the rider at risk of a fall or tip-over.
2. Adding a component to the frame, changing the structural integrity of the chair.
3. Any modification or disassembly can potentially create an unsafe situation where rider and/or attendant are put at risk.

E. KNOW YOUR DEVICE



Every device is different. Take the time to learn the feel of this chair before you begin riding. Start slowly, with easy, smooth strokes. If you are used to a different chair, you may use too much force and tip over. If you use too much force, damage to your chair, a fall, tip-over or loss of control may occur and cause severe injury to the rider or others.

F. TO REDUCE THE RISK OR AN ACCIDENT



1. BEFORE using this device, you should be trained in its safe use by your health care professional.
2. Practice transfers until you know your limits and the extent of your child’s abilities. Always ask if you need to have someone help you to avoid a fall or tip-over.
3. Be aware that you must develop your own methods for safe use best suited to your level of function and ability.
4. NEVER try a new maneuver on your own until you are sure you can do it safely.
5. Get to know the areas where you plan to use your device, look for hazards and learn how to avoid them.

G. SAFETY CHECKLIST**⚠ WARNING**

Before each use of the Early Intervention Device.

1. Parking brake must be adjusted to maintain proper performance. Always engage the parking brake before transferring a dependent child.
2. Check that the device rolls easily, and that all parts work smoothly. Check for noise, vibration, or a change in ease of use, (they may indicate loose fasteners, or other damage).
3. Repair any problems you may encounter. Your authorized dealer can help you find and correct any problems.
4. Make sure the tire/axle on both sides are fully engaged and locked. If they are not locked, the wheel may come off and cause a fall.
5. Never seat your child in the mobility device until it is fully unfolded and locked.
6. After adjusting handle length check to make sure that it is locked at the new length.
7. Always use a pelvic positioning belt when child is seated.
8. Never leave your child unattended.

H. CHANGES AND ADJUSTMENTS**⚠ WARNING**

1. If you modify or adjust this chair, it may increase the risk of a tip-over UNLESS you make other adjustments as well.
2. Consult your authorized dealer BEFORE you modify or adjust your chair.
3. We recommend that you use anti-tip tubes until you adapt to the change, and are sure you are not at risk to tip over.
4. Unauthorized modifications by the end-user, dealer or any other individual, including the use of parts not supplied or approved by Sunrise may change the chair structure. This will void the warranty and may cause a safety hazard.

If you fail to heed these warnings damage to your chair, a fall, tip-over or loss of control may occur and cause severe injury to the rider or others.

I. ENVIRONMENTAL CONDITIONS**⚠ WARNING**

1. Use extra care if you must use your device on a wet or slick surface. If you are in doubt, ask for help.
2. Contact with water or excess moisture may cause your device to rust or corrode. Avoid all extreme weather situations if possible.
 - a. Do not use your device in a shower, pool or other body of water. The chair tubing and parts are not water-tight and may rust or corrode from the inside.
 - b. Avoid excess moisture (for example, do not leave your device in a damp bathroom while taking a shower).
 - c. Dry your device as soon as you can if it gets wet, or if you use water to clean it.
 - d. Avoid contact with salt or salty conditions as this may cause damage to the device.

**J. TERRAIN****⚠ WARNING**

1. Based on ANSI/RESNA testing, Sunrise Medical recommends the use of a caster wheel with a minimum diameter of 5-in (127mm), if the wheelchair will be overcoming obstacles up to 1/2-in (12.7mm) on a regular basis.
2. Your chair is designed for use on firm, even surfaces such as concrete, asphalt, indoor flooring, and carpets.
3. Do not operate your chair in sand, loose soil, or over rocky terrain.
4. If you use your chair on terrain that is rougher than described above there is a danger that screws and bolts will loosen prematurely, and that damage to wheels or axles could put the rider at risk of a fall, tip-over, or loss of control.

If you fail to heed these warnings damage to your chair, a fall, tip-over or loss of control may occur and cause severe injury to the rider or others.

K. STREET USE**⚠ WARNING**

1. When using this device, avoid street use whenever possible.
2. This product should stay in, and obey all legal pedestrian pathways, and laws that apply to pedestrians.
3. Be alert to the danger of motor vehicles in parking lots.
4. At night, or when lighting is poor, use reflective tape or clothing for maximum visibility.
5. If you have to cross a road, make eye contact with drivers before you go forward. When in doubt, yield until you are sure it is safe.

If you fail to heed these warnings damage to your chair, a fall, tip-over or loss of control may occur and cause severe injury to the rider or others.

L. MOTOR VEHICLE SAFETY 1 2**⚠ WARNING**

If possible and feasible, the rider should transfer to the Original Equipment Manufacturer vehicle seat and use the OEM vehicle restraint.

Sunrise Medical does provide a WC-19 Wheelchair Tie-Down and Occupant Restraint System, otherwise called a Transit Option. To Identify whether your wheelchair has been manufactured with the Transit Option installed, look for four points of securement. Two Front points (A), and two rear points (B). These points are recognized by the securement point decal which can be found on or near the securement points.

If your wheelchair is equipped with the Transit Option, please review the Transit Securement supplement that was provided with the wheelchair for additional information and instructions. You can request a copy from your authorized dealer, or call Sunrise medical at 1-800-333-4000 if you don't have it.

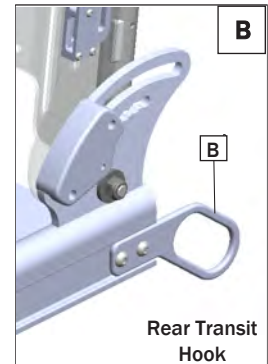
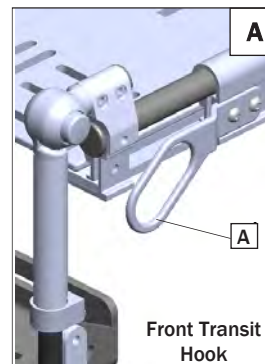

Look for this symbol on your wheelchair. It indicates wheelchair securement points which conform to ANSI/RESNA (1998) V.1 - Section 19 and/or ANSI/RESNA (2012) V.4 WC-19. For more Transit related information, see the "Transit Securement Supplement" included with your chair.

⚠ WARNING

If your device is **NOT** equipped with the Transit Option:

1. NEVER let anyone sit in this device while in a moving vehicle.
 - a. ALWAYS move the rider to an approved vehicle seat.
 - b. ALWAYS secure the rider with proper motor vehicle restraints.
2. In an accident or sudden stop the rider may be thrown from the device. Device seat belts will not prevent this, and further injury may result from the belts or straps.
3. NEVER transport this device in the front seat of a vehicle. It may shift and interfere with the driver.
4. ALWAYS secure this device so that it cannot roll or shift.
5. Do not use any device that has been involved in a motor vehicle accident. The frame and/or components may have been changed due to the accident. Such items could be, but are not limited to: bent, loosened, and/or broken components that were subjected to an impact.

Failure to heed these warnings puts you and others that may assist you at a high risk of injury.

M. WHEN YOU NEED HELP**WARNING****For The Rider:**

Make sure that each person who helps you reads and follows all warnings and instructions that apply.

For Attendants:

1. Work with the rider's doctor, nurse or therapist to learn safe methods best suited to your abilities and those of the rider.
2. Tell the rider what you plan to do, and explain what you expect the rider to do. This will put the rider at ease and reduce the risk of an accident.
3. Make sure the chair has push handles. They provide secure points for you to hold the rear of the chair to prevent a fall or tip-over. Check to make sure push handle grips will not rotate or slip off.
4. To prevent injury to your back, use good posture and proper body mechanics. When you lift or support the rider or tilt the chair, bend your knees slightly and keep your back as upright and straight as you can.
5. Remind the rider to lean back when you tilt the chair backward.
6. When you descend a curb or single step, slowly lower the chair in one easy movement. Do not let the chair drop the last few inches to the ground. This may damage the chair or injure the rider.
7. Whenever you aren't attending the wheelchair, ALWAYS use the wheel lock to secure the rear wheels, and lock the anti-tip tubes in place.

If you fail to ask for help when in doubt, you run a high risk of a fall, tip-over or loss of control that may occur and cause severe injury to the rider or others.

N. CHOKING HAZARD**WARNING**

NOTE- Your chair consists of many small parts that could present a choking hazard to young children. Take care to put parts out of reach when doing any work on the chair.

O. PINCH POINT**WARNING**

NOTE- Your wheelchair has many moving parts that can create pinch points and possible finger traps. Be aware when making any adjustments, when folding and unfolding, when moving, and any other situation that could cause a pinch point situation.

VI. WARNINGS: FALLS & TIP-OVERS

A. CENTER OF BALANCE**WARNING**

Dependent mobility devices are designed for stability and performance. The point where this device will tip forward, back, or to the side depends on its center of balance and stability. The center of balance is also affected by:

- The seat height and seat angle.
- Backrest angle.
- Changes in your child's body position, postures or weight distribution.
- Pushing the mobility device on a ramp or slope.
- The use of a backpack or other options, and the amount of added weight.
- The use of a vents, batteries, oxygen and other options, and the amount of added weight that these options add to the device.

To maintain the proper center of gravity and good balance:

- Consult your healthcare advisor and/or dealer to help you in setting up the mobility device correctly.
- Consult your authorized dealer or healthcare advisor BEFORE you modify or adjust the mobility device. Be aware that you may need to make other changes to correct the center of balance.
- Never hang items greater than 5lbs (2.3kg) from stroller handle or seat back handle.

B. DRESSING OR CHANGING CLOTHES**WARNING**

Your child's weight may shift if you dress your child or change your child's clothes while they are seated in the mobility device.

To reduce the risk of a fall or tip over while changing clothes or diapers:

- Rotate the front casters until they point forward.
- Engage the parking brake.

C. OBSTACLES**WARNING**

Obstacles and road hazards (such as potholes and broken pavement) can damage your mobility device and may cause a fall, tip over, or loss of control. To avoid these risks:

- Scan the area well ahead for danger as you travel with your mobility device.
- Make sure floor areas ahead are level and free of obstacles.
- Install a ramp at entry or exit doors. Make sure there is not a drop off at the bottom of the ramp.

D. REACHING OR LEANING**WARNING**

If your child reaches or leans it will affect the center of balance of the mobility device. This may cause a fall or tip over.

- NEVER allow your child to reach or lean if they must rise up off their seat for the action.
- If your child must reach, move the mobility device as close as you can to the object, and rotate the front casters until they are as far forward as possible.

NOTE- To do this: Move your mobility device past the object that the child might want to reach, then back up alongside it.

E. RAMPS, SLOPES AND SIDEHILLS**⚠ WARNING**

Pushing the mobility device on a slope, including ramps or hills, will change the center of balance. Some safety reminders include:

1. Do not push this product on a slope steeper than 6°.
2. Do not turn or change direction on a slope or ramp.
3. For your child's safety, ramps at home and work must meet all legal requirements for your location.
4. Always stay in the CENTER of the ramp.
5. Use a ramp with guardrails (or raised borders that are at least 3" high).
6. Always go straight up and straight down on hills or ramps.
7. Do not stop on a steep slope.
8. Watch for a drop-off at the bottom of a slope or ramp.
9. Do not engage the parking brake to slow or stop your mobility device.
10. Beware of wet or slippery surfaces, especially on slopes.
11. Do not recline or tilt the shell while going up hills.
12. Ask for help any time you are in doubt of stability.
13. Stay behind the chair.
14. Firmly grasp the handles.
15. For going up or down a ramp, the chair should always be facing forward.

If you fail to heed these warnings damage to your chair, a fall, tip-over or loss of control may occur and can possibly cause severe injury to the rider or others.

F. TRANSFERS**⚠ WARNING**

1. Work with your health care advisor to learn safe transfer and lifting methods.
2. Have someone help you until you know how to do a safe transfer of the dependent on your own.
3. Move your child's mobility device as close as you can to the location you are transferring to.
4. Rotate the front casters until they point forward.
5. Engage the parking brake before you transfer. This keeps the device stable during the transfer.
6. When transferring a child into the device, make sure they are placed as far back onto the seat surface as possible. This will reduce the risk that the mobility device will tip over and/or move away from you.

G. NEGOTIATING A CURB OR SINGLE STEP**⚠ WARNING**

Follow the instructions below for descending or climbing a stair or curb. **Do not try to climb a high curb or step more than 4-in (101mm) high, if the accessory tray, or rear glider platform is installed.** Doing so can risk injury, may cause the device to exceed its balance point and tip over, and may cause damage to the device.

To descend a curb or single step going FORWARD:

1. Stay at the rear of the mobility device.
2. Several feet before you reach the edge of the curb or step, tip the device slightly backward. When the device is at its balance point, carefully step forward until the rear wheels reach the edge of the curb or step.
3. Allow the rear wheels to slowly roll down onto the lower level. Push the chair forward until you are standing on the lower level.
4. Gently lower front casters to the ground.

To climb a step or curb going BACKWARD:

1. Stay behind the mobility device.
2. Continue backwards until the rear wheels contact the face of the curb or step. Lift and roll the rear wheels to the top of the curb.
3. Pull the device backwards until the caster wheels have cleared the edge of the curb and return the chair to its rolling position.

If you fail to heed these warnings damage to your chair, a fall, tip-over or loss of control may occur and can possibly cause severe injury to the rider or others.

H. CLIMBING STAIRS**⚠ WARNING**

1. Do not climb stairs if your mobility device has an accessory tray installed.
2. Use at least two attendants when moving the occupied mobility device up stairs.
3. The rider and mobility device should be facing BACKWARD when moving up the stairs.
4. ALWAYS carry the mobility device by holding the FRAME, being careful to avoid grabbing the footrest, wheels, tray parts, and other areas that are meant to detach from the mobility device.
5. The person at the rear should be in control. He or she should tilt the mobility device back to its balance point.
6. A second attendant at the front firmly grasps a non-detachable part of the front frame and lifts the mobility device up and over the stair.
7. The attendants should move up one stair at a time until the landing is reached.

I. DESCENDING STAIRS**⚠ WARNING**

1. Do not descend stairs if your mobility device has an accessory tray installed.
2. Use at least two attendants to move an occupied mobility device down stairs.
3. Move the mobility device with both the device and rider facing FORWARD down the stairs.
4. The person at the rear is in control. He or she tilts the mobility device back to the balance point of the rear wheels and rolls it to the edge of the top step.
5. A second attendant stands on the third step from the top and grasps the frame. He or she lowers the device one step at a time by letting the rear wheels roll over the stair edge.
6. The attendants should move down one stair at a time until the landing is reached.

J. ESCALATORS**⚠ WARNING**

NEVER use this mobility device on an escalator, even with an attendant.

⚠ WARNING

This early intervention device has been tested and approved using Sunrise accessories. Any accessory that has not been expressly approved by Sunrise Medical will void your warranty, and may add a safety risk to attendant and child.

A. BASE FRAME**⚠ WARNING**

Inspect cables and engage/release buttons before every use to make sure they are in good working condition. Be sure that your base frame is locked before seating your child.

B. UPPER EXTREMITY SUPPORT TRAY**⚠ WARNING**

Before adding or removing a tray to the mobility device be sure to point front casters to the front of the device and engage parking brake. This keeps the wheels from rolling when attaching the tray. The support tray has a weight capacity of 50lbs (22.7kg).

1. Do not lift this product by its tray support arms.
2. ALWAYS make certain that the tray is fully locked into place after adding it to the dependent mobility device.

C. FASTENERS**⚠ WARNING**

Many of the screws, and nuts on this product are considered to be special high-strength fasteners. They require periodic checks and maintenance to ensure the safety of both the user and attendant.

1. Most adjustments that require removing hardware should be done by your Service provider.
2. Only use fasteners provided by an authorized dealer (or ones of the same type and strength), as indicated by the markings on the heads.
3. Do not over- or under-tighten fasteners. If screws or nuts become loose, tighten them as soon as possible.

NOTE- For safety and performance it is best to not reuse fasteners.

If you fail to heed these warnings damage to your chair, a fall, tip-over or loss of control may occur and cause severe injury to the rider or others.

D. FOOTREST**⚠ WARNING**

1. Adjustment of the footbed may cause interference with the front lower frame in some positions. This interference can affect the comfort and proper support for the seated dependent.
2. Avoid putting extra weight on the footbed. The mobility device may tip forward (or backward if seating system has been reversed).
3. Never lift this mobility device by the footbeds.

E. TIRES AND WHEELS**⚠ WARNING**

1. Yearly tire inspection for excessive wear is suggested to ensure good traction in all types of environments.
2. When installing front or rear wheel/tire assembly, slide the wheels into the axle opening until the quick release button pops out, and you hear a click. Your wheel is now fully engaged and locked.

F. PARKING BRAKE**⚠ WARNING**

Never engage the parking brake to slow or stop this product when it is moving. To keep the rear wheels from rolling, always engage the parking brake fully when you transfer your dependent or the dependent seating system.

G. UNDERCARRIAGE STORAGE**⚠ WARNING**

This mobility device's storage basket was designed for the addition of up to 15lbs (6.8kg) of additional weight. Excessive weight may cause an unstable or hazardous condition to exist.

H. ACCESSORY TRAYS**⚠ WARNING**

The accessory trays should not be used to store excessive weight, or a piece of equipment that has not been approved for use by Sunrise Medical. This may cause an unstable or hazardous condition for the rider or attendant.

I. CANOPY**⚠ WARNING**

When using the canopy, make sure that it is secure by checking the clamps that hold it to the base.

J. SEATING SYSTEMS**⚠ WARNING**

DO NOT change the seating system, or individual components of your dependent mobility device unless you have first consulted your health care professional.

K. PELVIC POSITIONING BELTS**⚠ WARNING**

Use positioning belts ONLY to help support the child's posture.

1. Make sure the rider does not slide down in the mobility device seat. The belts must be snug, but must not be so tight that they interfere with breathing. You should be able to slide your open, flat hand, between the belt and the rider.
2. Use positioning belts with a cooperative rider only. Make sure that you can remove the belts in an emergency.
3. NEVER use the positioning belts:
 - As a restraint.
 - On a child who is comatose, agitated or is prone to seizures.
 - As a motor vehicle restraint— except those that are included with the transit option for the purpose of occupant restraint.

L. CUSHIONS**⚠ WARNING**

This mobility device's seating was designed for comfort and postural support. If seating component modifications are necessary, consult your healthcare advisor.

M. TILT AND RECLINE

⚠ WARNING

Using the tilt or recline adjustments triggers before taking the necessary precautions may effect the balance and stability of your device. BEFORE making these adjustments you must be aware of the following:

1. The child must be secure in the device.
2. You must rotate the front casters forward, and engage the parking brake.
3. ALWAYS make certain that the dependent mobility device is level and stable before and after adjusting the tilt and/or recline.
4. ALWAYS support the seating shell when releasing the tilt trigger.

NOTE: When fitted with the Advanced Seating system and in the rearward facing configuration, maximum posterior (forward) tilt range may be limited.

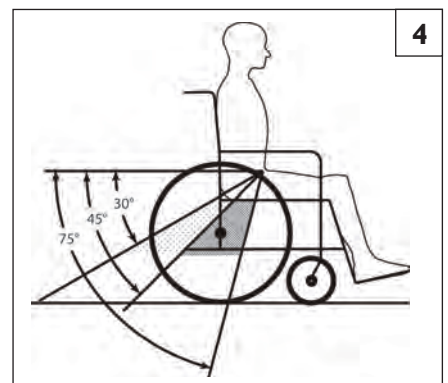
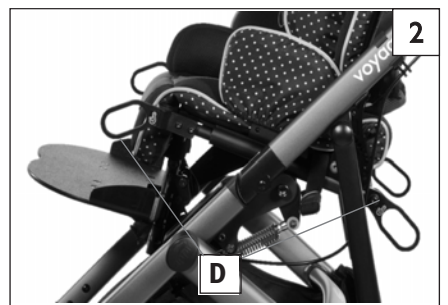

N. TRANSIT OPTION AND USE 1 2 3 4

NOTE- The Zippie Voyage has passed transit testing and is considered to be ISO 7176-19 compliant for a dependent child weighing at least 51 lbs. (23 kg) and up to 75 lbs. (34 kg), and ANSI RESNA WC19 compliant for a dependent at least 26 lbs (12 kg) and up to 50 lbs. (23 kg) using the Advanced Seating System only. In transit, the occupant must be secured within the vehicle and secured in a 3 point harness. Transit straps should be secured to the front and rear transit loops (D).

⚠ WARNING

1. It is recommended that the Zippie Voyage not be used to transport occupants weighing 25lbs (11kg) or less. Rather, occupants 25lbs (11kg) or less should be transported using a suitable rearward facing infant car seat.
2. If possible and feasible, the occupant should transfer to the vehicle seat and use the OEM vehicle-installed restraints.
3. The occupant must be facing the front of the vehicle during transport.
4. Wheelchair Tiedown and Occupant Restraint Systems (WTORS) must be used.
5. A Wheelchair Tie-down that has been tested in accordance with SAE J2249 must also be used in any transit situation.
6. The Occupant must be restrained with a vehicle anchored 3-point Belt.
7. For all transit situations you must use the Transit Strap (B) provided with your device (Fig. 1). It secures the seating shell to the rear frame. It is critical that the strap be threaded through the 2 "D" clips (C) as shown in (Fig. 1) for the safety of the occupant.
8. Mobility device mounted accessories, such as trays and respiratory equipment, and batteries, should be removed, and secured separately. The optional Voyage vent tray, oxygen holder, and IV pole must also be removed and secured separately before using as a seat in a motor vehicle.
9. The occupant must not weigh more than 75lbs. (34 Kg).
10. The location(s) of the front and rear securement points (D) are shown in (Fig. 2 and marked with a transit point label for clear identification.
11. Use only with WTORS that have been installed in accordance with the manufacturer's instructions and SAE J2249. Attach WTORS to the securement points (A) in accordance with the manufacturer's instructions and SAE J224
12. The vehicle anchored 3 Point Belt is used for occupants 25 to 75 lbs. The angle of the pelvic belt should be within the preferred zone of 45 to 75 degrees to the horizontal, or within the optional zone of 30 to 45 degrees to the horizontal (Fig. 3)
13. The vehicle anchored 3 Point Belt should be worn low across the front of the pelvis. Position upper torso belts over the shoulders. The belt(s) should not be held away from the body by wheelchair components. Ensure that the belts are not twisted.
14. If a recline angle is required during transport, the chair seat/back should be positioned at an angle of no more than 30° to the vertical, or the occupant is at risk of injury in the event of an accident or collision.
15. Attach all occupant restraints in accordance with the manufacturer's instructions and SAE J2249.

NOTE- To obtain a copy of SAE J2249 "Wheelchair Tiedown and Occupant Restraint Systems for Use in Motor Vehicles" Please contact:
 SAE International, 400 Commonwealth Drive
 Warrendale, PA 15096-0001
 or by phone at (724)-776-4841



Look for this symbol on your wheelchair. It indicates wheelchair securement points which conform to ANSI/RESNA (1998) V.1 - Section 19 and/or ANSI/RESNA (2012) V.4 WC-19, and ISO 7176-19.

⚠ WARNING

The owner of this chair is responsible for making sure that it has been setup and adjusted by a trained service professional under the advice of a healthcare advisor. The chair may require periodic safety and function checks or certain tool free adjustments that can be performed by the owner, caregiver or authorized dealer if desired. Always use parts and/or accessories that have been recommended or approved by Sunrise Medical when servicing this chair.

A. MAINTENANCE AND SAFETY NOTES

1. Proper maintenance will improve performance and extend the useful life of your mobility device.
2. Clean the device regularly. This will help you find loose or worn parts and will make your device easier to use.
3. To protect your investment, have all major service and repair work done by your dealer.
4. At least every four months, check all screws and knobs for tightness. If parts are missing, broken, damaged or worn, then discontinue use of the product until repairs are made, using factory-authorized parts.
5. Wipe down all plastic components periodically with a solution of mild soapy water to maintain cleanliness.
6. Hand wash and air-dry the fabric components as needed.
7. Lubricate all moving metal parts with a Teflon lubricant only.

NOTE - Using lubricant other than Teflon based may damage moving parts

8. Check the parking brake lock pin weekly to make sure it engages smoothly into the wheel hub. This simple check will insure the safety of the rider. Lubricate with a Teflon Lubricant when needed.
9. Check and clean the wheel attachment points frequently, this is a main area that can collect dirt and grime. Debris in this area can effect the performance and safety of the device.

⚠ WARNING

1. Your device needs regular maintenance for peak performance and to avoid injury from a device failure, damage or premature wear.
2. Inspect and maintain this device strictly using this Owner's manual as a reference.
3. If you detect a problem, make sure to service or repair the device before putting it back into use.
4. At east once a year, have a complete safety check and service of your device performed your dealer.

B. CLEANING

Base Frame Parts:

- Clean with mild soapy water monthly.

Upholstery:

- Hand wash as needed. Machine wash as needed.
- Drip dry only. Heat from a dryer may damage fabric.

NOTE - Washing the fabric may decrease fire retardant properties.

C. STORAGE TIPS

1. Store your device in a clean, dry area. If you fail to do so, parts may rust or corrode.
2. Before using your mobility device, make sure it is in proper working order. Inspect and service all items included in this Manual.
3. If you store this device for more than three months, have it inspected by a dealer before use.

D. SAFETY CHECKLIST

Weekly	Monthly	3 Months	6 Months	Annually	Safety & Function Check
<input checked="" type="checkbox"/>					Tire inspection (excessive wear, cracks)
<input checked="" type="checkbox"/>					Parking brake holds firm (no slipping)
		<input checked="" type="checkbox"/>			Visually check for loose hardware
			<input checked="" type="checkbox"/>		Securement and positioning belts
			<input checked="" type="checkbox"/>		Axle and axle sleeves (check for debris)
		<input checked="" type="checkbox"/>			Quick-release axles (remove, clean)
<input checked="" type="checkbox"/>					Caster tires (excessive wear, cracks)
		<input checked="" type="checkbox"/>			Casters (level, and move smoothly)
		<input checked="" type="checkbox"/>			Seating interface (check for debris)
			<input checked="" type="checkbox"/>		Frame, Folding Mechanism
	<input checked="" type="checkbox"/>				Upholstery (clean and dry)
				<input checked="" type="checkbox"/>	Service by Authorized Dealer

NOTE - The user or caregiver should perform these weekly and monthly checks to maintain the safety of their chair. If an item is not working properly, please contact your authorized dealer.

E. UNFOLDING AND FOLDING BASE FRAME

⚠ WARNING

Zippie dependent mobility devices are designed for stability and performance. When unfolded, the device must be fully open and locked to avoid injury to the dependent rider. Follow the instructions for unfolding the device carefully, and double-check that the device is fully locked before adding the seating shell and rider.

Unfolding: 5 6 7

- a. Unsnap the storage lock (A) from around the folded frame. It should remain attached to the frame for future use.
- b. Pull up on the upper frame (B) until it locks into place. It may be necessary to put your foot on the bottom bar while pulling up on the upper frame. Fig. 7.
- c. Rear wheels and front casters can now be attached if they are not attached already.

Folding: 5 7 8

⚠ WARNING

The Voyage is not intended to be folded with the seating system installed. ALWAYS remove the seating system prior to folding the base. Failure to do this may damage the product.

- a. Remove child from the seating system, then remove the seating system from the base (refer to sub-section J).
- b. Unlock the front caster wheels.
- c. Return handle to the straight position as show in Figure 8.
- d. Set parking brake.
- e. Pull up on both triggers (D) at the same time. This action will release the frame lock. Continue pulling up on the triggers while pushing down on the upper frame.
- f. Push handle down to begin folding of the base.
- g. Lift on the center tube of the Slide-N-Lock (C). Fig. 7.
- h. Snap the storage lock (A) around the upper frame to prevent the frame from opening when transporting, or storing the frame.

NOTE - Rear wheels, or front casters do not have to be removed for this procedure, but may be removed to save space for storage.

Do not force the base open or closed if it sticks during unfolding or folding, damage could occur.



F. CASTER WHEELS

Installing and Removing the Caster Wheels 9

- a. Locate the caster stem guide hole location on the bottom of the Voyage frame. Line up the caster stem (A) with the hole, while pushing in tab (B) insert the caster stem until it clicks into place. Check the secure engagement to the base by pulling on the caster wheel. If it does not move the caster wheel has been installed properly. Repeat this procedure for other side.
- b. To remove the caster wheel, press in tab (B) and pull the caster wheel out.

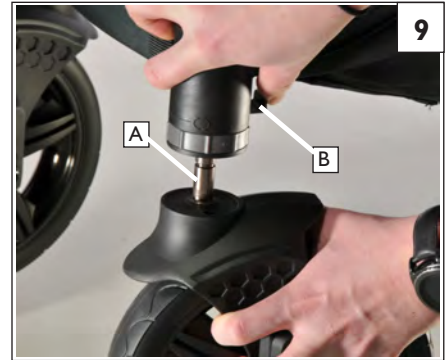

Caster Wheel Locks 10

- a. To lock the caster wheel, locate the lock ring (C). Turn the lock ring clockwise until it clicks into place. Do this with both of the front caster wheels, and check to insure that the lock has been engaged.
- b. To unlock the caster wheel turn the lock ring counter clockwise until the wheel freely rotates.



G. REAR WHEELS 11

Installing and Removing the Rear Wheels

- a. To install rear wheel, gently slide the rear wheel's axle (D) into the hole in the frame until the wheel clicks into place.
- b. To remove the rear wheel, simply press down on wheel tab (E) while gently sliding the wheel away from the frame.

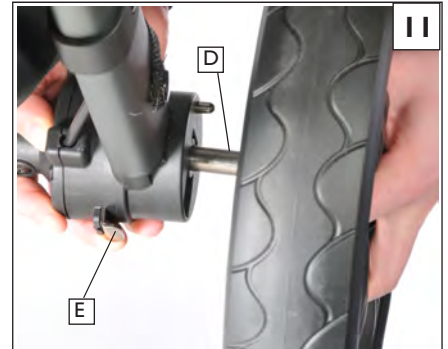

H. PARKING BRAKE OPERATION 12 13

Engage or Disengage the Parking Brake

- a. Engage the parking brake by gently pushing down with your foot on the brake foot pedal (F).
- b. To release the parking brake, push forward on vertical lever (G).



I. SEATING INSTALLATION **14 15 16 17 18 19 20**

⚠ WARNING

BEFORE installing the seating shell, always check that the mobility device is completely unfolded and in the locked position, and that all four wheels are locked in place. The seating shell should never be installed with a seated occupant. Always remember to stabilize the mobility device before performing this action.

- Rotate the front casters until they point forward.
- Engage the parking brake.

The seating shell has a latch mounted underneath the seat plate. The interface on the base is the counterpart to the latch and mates with the latch. The seating shell may be installed so that the child can face either frontwards or rearwards. Installation is the same in either direction.

Using the latch lock

NOTE - The latch under the seat plate has a lock that can be used to provide additional securement after the seat is installed.

- BEFORE attaching or removing the seat to or from the base, the latch lock (K) MUST be slid to the right (unlocked position) as shown in Fig 14.
- To prevent inadvertent activation of the seat latch, slide the latch lock to the left as shown in Fig 15 AFTER the seat is fully secured to the base (you cannot attach seat to base while lock is engaged).

Rotating the seat shell direction

- Lock the wheels, remove the seat.
- Be sure the Tilt setting is at the "home" or 0° position. Do this by squeezing the Tilt Release lever and letting the "Slide-n-Lock" (Receiver) Plate spring flat.
- STEP 1:** Press the Gold Button, Numbered 1 (A) on the Slide-n-Lock plate and rotate the plate until it stops (Fig 16).
- STEP 2:** Pull the Pin (B) with one hand and rotate the Tilt Limiter Sleeve (C) with your other hand* (Fig 17 and 18).

NOTE - Only rotate the Tilt Limiter Sleeve in the process of Rotating the Plate.

*When the seat is forward facing the Tilt Limiter Sleeve should be rotated Rearward; when the seat is rearward facing the Sleeve should be rotated Forward.

- STEP 3:** Finish rotating the Plate 180° until it locks into place (Fig 19).

NOTE - When fitted with an Advanced Seating system, maximum posterior (forward) tilt range may be limited.

Install the seating shell

NOTE - When installing the Moderate Seating System in the rearward facing direction, raise the footrest to about a 5 degree angle, to clear the stroller base crossbar and allow seat to lock into the receiver.

- Make sure the seat is in the fully upright position (no recline or tilt).
- Ensure all positioning straps and accessories are out of the way and will not interfere with the seat from fully engaging the receiver.
- For moderate seating system only:** Line up the alignment tag (D) with the support cross bar (E) on the base (Fig 20).
- Lower the seating shell so that the seating shell and mounting plate are in contact.
- Slide the seat backwards evenly. You should hear an audible click. Check the secure engagement to the base by pulling up on both sides. If it does not move or tilt, the seating shell is now locked and has been installed properly.
- Once locked into place, add the occupant for transportation and/or adjustment.

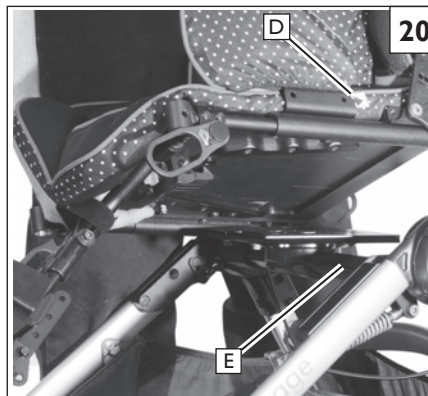
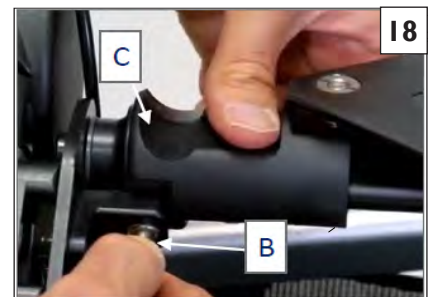
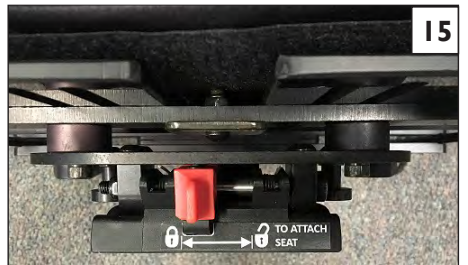
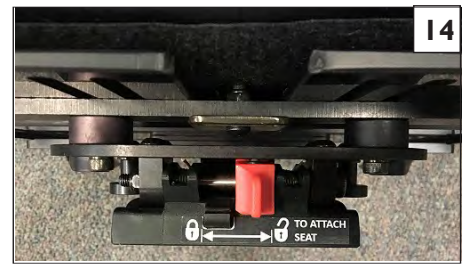

J. REMOVING THE SEATING SHELL 21

WARNING

BEFORE removing the seating shell, always remove the occupant to a safe location. Failure to do so may result in injury to the dependent, and/or caregiver. Always remember to stabilize the mobility device before performing this action.

- Rotate the front casters until they point forward.
- Engage the parking brake.

After removing the occupant:

- Make sure the seat is in the fully upright position (no recline or tilt)
- Pull and hold release lever (F) so that it disengages from the receiver, slide the seating shell forwards and lift the seating shell from the base.
- The seating shell is now ready to be inspected and/or stored.

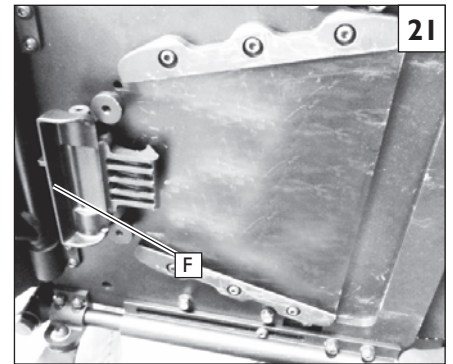

K. GRAB BAR 22

Always stabilize the mobility device before performing the action.

- Rotate the front casters until they point forward.
- Engage the parking brake.

Insert or remove the Grab Handle

- Be careful to avoid pulling or crimping any life support tubing that may be attached to the child. This adjustment can create a pinch point, so be careful to remove any obstruction, and/or clothing that could get stuck in this area.
- The adjustment is made from the front of the device. Depress both upper detent pins (H) simultaneously, and either insert or remove the Grab bar (G)
- If you are inserting the Grab Bar (G), push the bar in far enough so that the detent pins pop out of the locking hole (J).
- Pull up on the bar to make sure that it is locked into place.
- Depending on preference, grab bar is reversible.

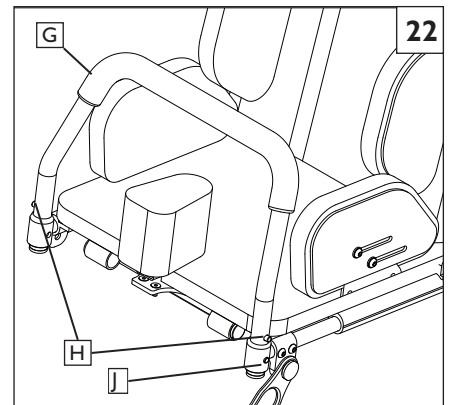

L. TILT IN SPACE ANGLE ADJUSTMENT 23

WARNING

BEFORE using the tilt adjustment, always check that the mobility device is completely unfolded and in the locked position, and that all four wheels are locked in place. Be careful to avoid pulling or crimping any life support tubing that may be attached to the child. Always remember to stabilize the mobility device before performing this action.

- Rotate the front casters until they point forward.
- Engage the parking brake.

Tilt adjustment

- Remove the safety pin (A) to allow tilt.
- Support the seating shell with one hand and release the tilt lever (B) on the back side of the frame. Position shell to the desired angle adjustment. The back support, and seating support components, including the footrest will move together.
- Release the handle and gently pull on the seating shell to make sure it is locked in the new position. Replace the safety pin to lock out the adjustment.
- This adjustment can change the balance of the device slightly so it is good to check that there is no danger of tipping with the new setting.



M. RECLINE ADJUSTMENT 24

WARNING

BEFORE using the recline adjustment, always check that the mobility device is completely unfolded and in the locked position, and that all four wheels are locked in place. Be careful to avoid pulling or crimping any life support tubing that may be attached to the child. Always remember to stabilize the mobility device before performing this action.

- Rotate the front casters until they point forward.
- Engage the parking brake.
- If equipped with shoulder harness, loosen the shoulder straps to allow room for the recline.



M. RECLINE ADJUSTMENT 24**WARNING**

BEFORE using the recline adjustment, always check that the mobility device is completely unfolded and in the locked position, and that all four wheels are locked in place. Be careful to avoid pulling or crimping any life support tubing that may be attached to the child. Always remember to stabilize the mobility device before performing this action.

- Rotate the front casters until they point forward.
- Engage the parking brake.
- If equipped with shoulder harness, loosen the shoulder straps to allow room for the recline.

Recline adjustment

- Remove the safety pin from the recline lever. From behind your mobility device, grasp the recline lever (C). Squeeze the lever then pull on the back support area. (The back should move independently of the seating support and footrest). When desired angle adjustment has been reached, release the handle and gently pull on the seating shell to make sure it is locked in the new position, and replace the safety pin.
- This adjustment can change the balance of the device slightly so it is good to check that there is no danger of tipping with the new setting.
- If equipped with shoulder harness, adjust again the straps for proper fit.

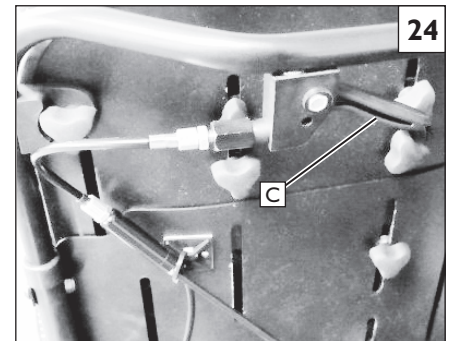
**N. KNEE ANGLE ADJUSTMENT (ADVANCED SEATING)** 25**WARNING**

Always stabilize the mobility device before performing this action.

- Rotate the front casters until they point forward.
- Engage the parking brake.

Knee angle adjustment (ADVANCED)

- Be careful to avoid pulling or crimping any life support tubing that may be attached to the child. This adjustment can create a pinch point, so be careful to remove any obstruction, and/or clothing that could get stuck in this area.
- The adjustment is made from the front of the device. Depress both legrest pivot buttons (D) simultaneously, and adjust to desired angle.
- Release the buttons and allow the legrest to lock into place.

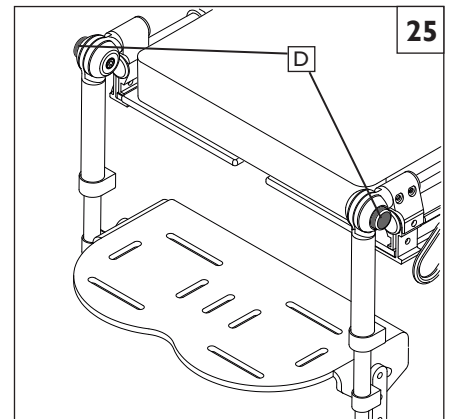
**O. KNEE ANGLE ADJUSTMENT (MODERATE SEATING)** 26**WARNING**

Always stabilize the mobility device before performing this action.

- Rotate the front casters until they point forward.
- Engage the parking brake.

Knee angle adjustment (Moderate Seating Shell)

- Be careful to avoid pulling or crimping any life support tubing that may be attached to the child. This adjustment can create a pinch point, so be careful to remove any obstruction, and/or clothing that could get stuck in this area.
- Release the quick release lever (A) and adjust the Knee angle to the desired angle.
- Fasten the quick release lever properly after every adjustment

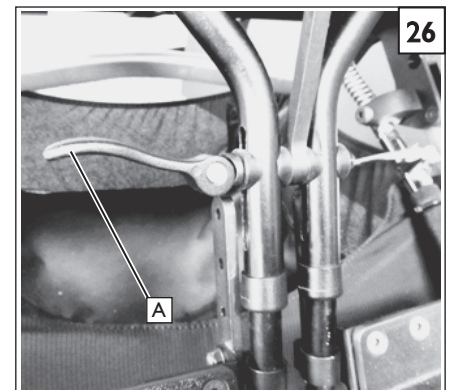

P. CANOPY INSTALLATION AND ADJUSTMENT

⚠ WARNING

It is always best to make sure the dependent is not seated in the mobility device during the installation of accessories.

Canopy installation 27 28

- a. From behind your mobility device, attach the canopy to the seating shell receivers (B).
- b. Check that the canopy has been installed correctly by visual inspection and checking for looseness, or an incorrect attachment. The plastic tabs (C) must be locked into place for safe operation.

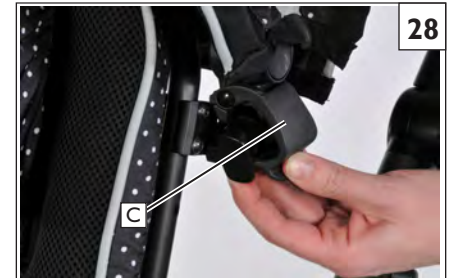

Q. ANGLE ADJUSTABLE STROLLER HANDLE 29

To adjust the Handle

The handle angle is adjustable for pushing comfort.

- a. The adjustment is made from the back of the device. Depress both stroller handle pivot buttons (F) simultaneously, and adjust to desired angle.
- b. Release the buttons and allow the stroller handle to lock into place.

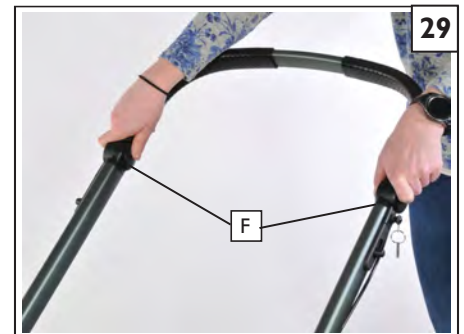

XI. DEALER SERVICE AND ADJUSTMENTS

A. POSITIONING AND GROWTH ADJUSTMENTS

⚠ WARNING

If a change in adjustment is necessary for growth or positioning, a healthcare professional must be consulted before any changes are made. These adjustments are very important to the orthopedic and neurological needs of the child. Care should be taken to make sure the changes are physiologically and medically appropriate. Sunrise Medical suggests that any positioning or growth adjustments be made by your service provider. Do not allow any adjustments while the child is seated in the mobility device.

If you plan to adjust and maintain this device yourself, Sunrise recommends that you use a torque wrench.

NOTE - The torque wrench must measure inch-pounds. You may buy a torque wrench and proper metric sockets from any local hardware store.

1. Torque settings:

A torque setting is the optimum tightening which should be made on a particular fastener. It is important to use proper torque settings where specified. When not specified, torque settings should be: M5 fasteners = 44 in-lbs (5 Nm), M6 fasteners = 62 in-lbs (7 Nm), M8 fasteners = 88 in-lbs (10 Nm). For all others torque setting should be 60 in-lbs (6.8 Nm).

2. Dealer Service and Adjustment Reference materials:

Go to www.sunrisemedical.com for parts manuals, instruction sheets, and instructional videos that will aid in the repair of the Quickie/Zippie Family of wheelchairs.

In general, positioning and growth adjustments should be done in the following order:

1. Adjust seated area
2. Adjust back support area
3. Adjust pelvic positioning belt
4. Adjust footplate
5. Adjust head support(s)
6. Make other standard and optional adjustments that are needed
7. Check to be sure that all adjustment screws are torqued to specifications.

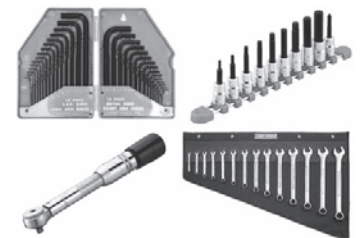

TOOLS YOU WILL NEED

1. Imperial Hex key set
2. Metric Hex key set
3. Imperial Open-end Wrench set
4. Metric Open-end Wrench set
5. Torque wrench
6. Imperial Hex bit Socket set
7. Metric Hex bit Socket set
8. Phillips and Flat screwdrivers

B. SEAT DEPTH ADJUSTMENT (MODERATE SEATING) 30

- a. Start by determining the proper seat cushion depth.
- b. Remove the seat cushion. It is attached with Velcro®.
- c. Loosen the screws (A) on both sides (do not remove)
- d. Loosen the four nuts (B). The hardware may need to be removed for certain adjustments.
- e. Adjust the depth by sliding the front of the seat pan forward, or backwards.
- f. Tighten again hardware (A) and (B) to (75-85 in-lbs (8.5-9.5 Nm) and attach again the cushion.

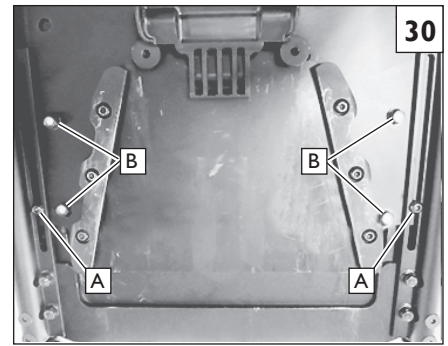

C. SEAT DEPTH ADJUSTMENT (ADVANCED SEATING) 31 32

- a. Start by determining the proper seat cushion depth.
- b. Remove the seat cushion. It is attached with Velcro®.

Adjusting Seat Pan to increase depth.

- a. Loosen the screws (A) on both sides, found at the ends of the sideframe.
- b. Loosen the two screws (B) that hold the seat pan in place.
- c. You can slide the combination of seat pan and footrest platform to adjust the seat depth. Tighten the screws.
- d. If more depth is needed loosen the asymmetric leg plates (C) and move forward to appropriate depth. Tighten the screws.

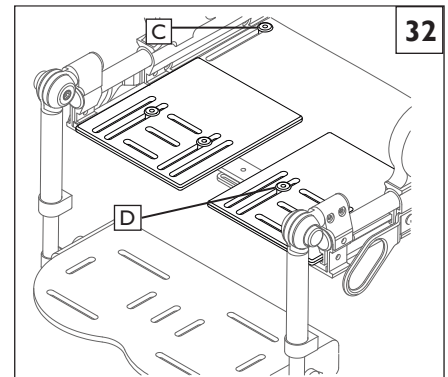
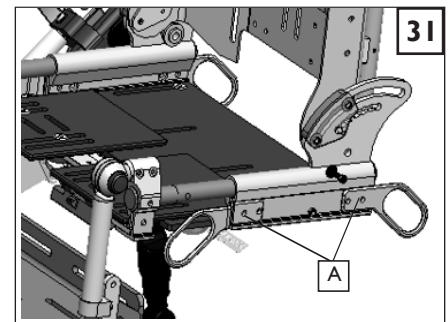

D. CUSHION ADJUSTMENT (ADVANCED SEATING) 33 34

The standard seat cushion comes in three seat lengths: short, medium, and long. The short seat is 8-in (203mm) long, the medium seat is 10-in (254mm), and the long is 13-in (330mm). Any excess cushion for each range should extend under the back shell behind the seat. The cushions can adjust 5.5-in to 11.5-in (140 to 292mm) in width by adding or removing adductor foam pads.

Cushion types

1. Standard (A), ledge (B), and wedge (C)
2. Each type of cushion affects the child's posture in a different and specific way.
3. Be sure to consult your health care advisor before changing the type of cushion.

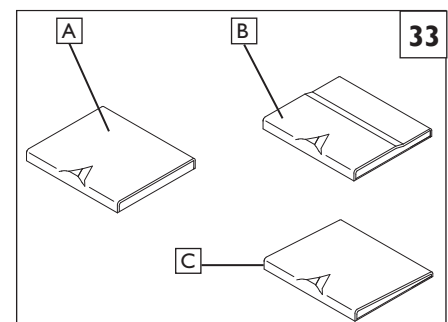

To adjust the width

- a. Unzip and remove seat cover. Add or remove the same combination of adductor foam pads (D) from each side of the seat, to achieve the desired width.
- b. Assemble again the cover over the seat and pads, and close the zipper.

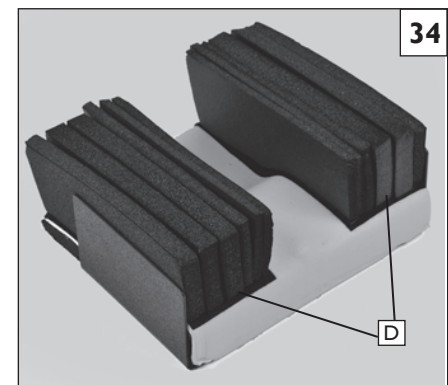

E. ADJUSTABLE CONTOUR CUSHION ADJUSTMENT 35 (ADVANCED SEATING)

The contoured seat cushion comes in three seat lengths: short, medium, and long. The short seat is 5-in (127mm) long, the medium seat is 7-in (178mm), and the long is 9-in (229mm). These cushions can be grown by an additional 3-in (76mm) by adding a 3-in (76mm) growth strip at the back of the cushion. The front and rear section of the cushion (D) has Velcro® attachment points for positioning the adductor wedges provided. They attach to the front and rear section of the cushion under the foam overlay. The foam overlay attaches to Velcro® at the back of the seat.

Adding growth strips

- a. Unzip seat cover and fold the top over the front edge to expose the cushion.
- b. Lift the foam overlay piece away from the Velcro® attachment, using care not to tear the foam.
- c. Grasp the rear foam section at the middle and lift it from the Velcro® attachment.
- d. Add either the 2-in (51mm) or the 3-in (76mm) growth strip at the back of the front foam section assuring that the angled edges and sides align, and black foam is facing down.
- e. Attach again the rear section assuring the angled edges and sides align.
- f. Adjust the adductor wedges as needed and position the foam overlay over the cushion and attach to the Velcro® at the rear of the seat.
- g. Close the zipper around the cushion and assemble again into the unit.

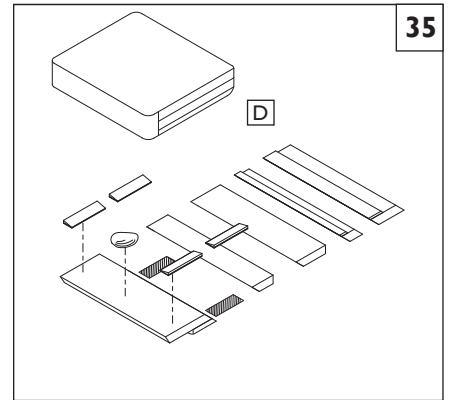

Cleaning the seat cover 36

- a. Unzip the cover (E) along the edge.
- b. Remove the cushion assembly from the Velcro® attachment inside the cover.
- c. The fabric seat cover should be hand washed with laundry soap, thoroughly rinsed with clean water, and air dried.
- d. The foam cushion pieces may be wiped down with soap and water. Always be sure they are completely dry before replacing the fabric cover.
- e. Place the cushion into the fabric cover and onto the Velcro® with the front edge of the cushion aligned with the front edge of the cover.
- f. Pull the cover over the cushion and close the zipper around the cover.

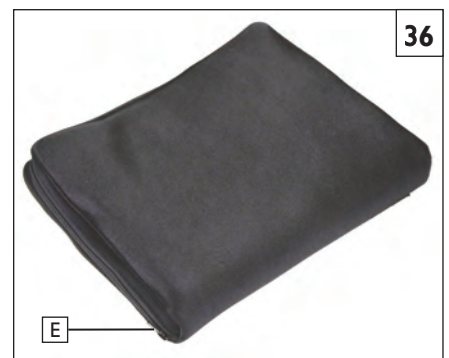

F. PLANAR CUSHION WITHOUT LATERAL SUPPORTS (ADVANCED SEATING)

Adding growth strips

The standard cushion without lateral hip supports comes in three seat lengths: short, medium, and long. The short seat is 8-in (203mm) in length, the medium seat is 10-in (254mm), and the long is 13-in (330mm).

G. SHOULDER STRAP HEIGHT ADJUSTMENT 37 (ADVANCED SEATING)

- a. Open the exterior back panel cover from the rear of the device to expose the back growth slots, and adjustment screws.
- b. **Loosen**, do not remove (4), screws (A) through the access holes behind the back plate on each side. Adjust shoulder strap bar to proper height. Tighten all of the adjustment screws to 45 in-lbs (5Nm) (do not over-tighten) and then adjust again the shoulder straps for a comfortable fit.

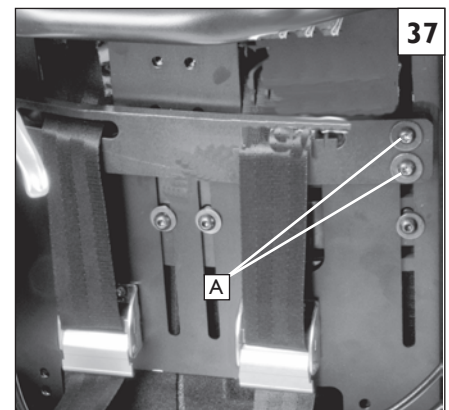

H. BACK CUSHION HEIGHT ADJUSTMENT (ADVANCED SEATING)

- a. Fit the back cushion to the positioning plate at proper height.
- b. Exchange appropriate back cushion inserts if a gap is present at the bottom of the back cushion.

I. SEAT TO BACK ANGLE ADJUSTMENT 38 (ADVANCED WITHOUT RECLINE OPTION)



For ease of adjustment, and safety of the dependent, remove the occupant before any adjustment is made. Always stabilize the mobility device before performing this action.

- Rotate the front casters until they point forward.
- Engage the parking brake.

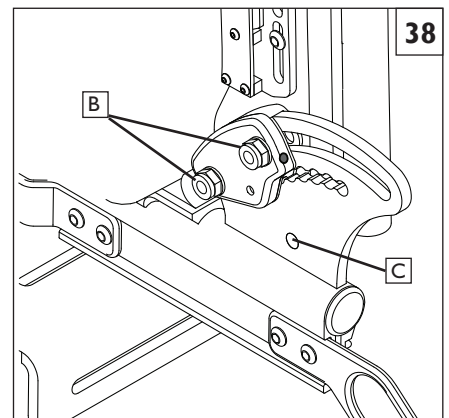

SEAT TO BACK ANGLE ADJUSTMENT (Continued)

To adjust seat to back angle:

- a. This adjustment should be performed by a healthcare professional
- b. There are 7 different settings available, from 90° to 135° in 7.5 degree increments.
- c. Remove the nylock nuts (B) and plastic cover.
- d. Remove the hole pin from the post (C) and repeat steps on other side of the device.
- e. Adjust angle to desired location and assemble again the hole pins.
- f. Tighten the button-head screws and nuts (B) to 30 - 35 in-lbs (3.4 - 4Nm) (do not overtighten) to lock the adjustment into place.
- g. This adjustment can change the balance of the device so it is good to check that there is no danger of tipping with the new setting.

J. BACK HEIGHT ADJUSTMENT (MODERATE SEATING) 39



WARNING

For ease of adjustment, and safety of the dependent, remove the occupant before any adjustment is made. Always stabilize the mobility device before performing this action.

- Rotate the front casters until they point forward.
- Engage the parking brake.

Quick adjustment (up to 100mm (3.9-in))

- a. Loosen the four knobs (D) and (E) on the back

NOTE- If Laterals are being used, loosen, or remove if necessary, those attachment knobs as well.

- b. Adjust the height by sliding the upper backrest shell up or down.
- c. Tighten again the knobs (D)(E).

Height adjust (more than 100mm (3.9-in))

- a. Remove the top screws on the backcanes (F). In some cases it might be necessary to remove the bottom screws(F) as well.
- b. Loosen or remove the two bottom knobs (D).

NOTE- If Laterals are being used, loosen, or remove if necessary, those attachment knobs as well.

- c. Slide the handle and backshell assembly up or down to the next set of adjustment holes on the back handle.
- d. Attach and tighten the button-head screws (F) and knobs (D) (do not overtighten) to lock the adjustment into place.
- e. Replace the backrest cushion.

NOTE - This adjustment can change the balance of the device so it is good to check that there is no danger of tipping with the new setting.

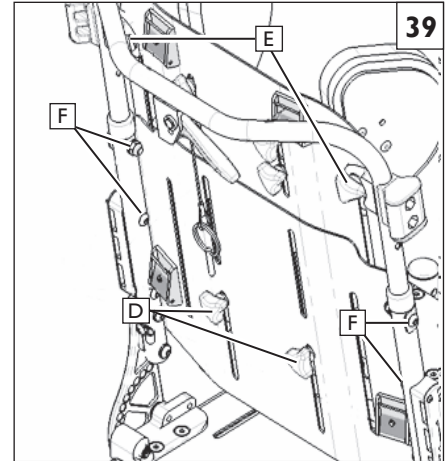

K. FOOTREST ADJUSTMENTS (ADVANCED SEATING) (0)

Height Adjustment

The height adjustment for the footrest consists of two telescoping tube sections which lock the footrest height.

- a. Identify adjustment screw locations (A) on the rear side of the footrest hanger.
- b. First loosen the upper screws on each side of the footrest hanger.
- c. Slide the footrest up or down to proper height.
- d. Tighten the upper screw to 15-20 in-lbs (1.69-2.6 Nm) (do not overtighten)
- e. Repeat procedure using lower screw if additional range is required.

NOTE - Footrest is shown inverted for shortest possible leg length. It can be attached either way by flipping the footrest for more height or more secure foot placement.

Angle Adjustment

- a. The footrest has two screws (B) and (C) that control footrest rotation. Loosen both screws on each side of the footrest as shown in (Figure 39).
- b. Adjust the footrest to proper angle.
- c. Tighten the adjustment screws to 40-45 in-lbs (4.5-5 Nm) to maintain proper footrest angle.

NOTE - (Do not overtighten this hardware against plastic parts).

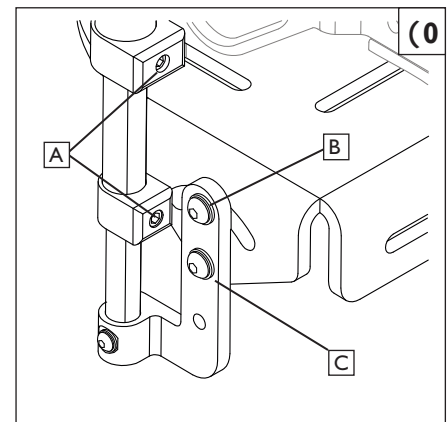

FOOTREST ADJUSTMENT (Continued)

Flipping the footplate for max lower leg length 41

The foot bed is designed to flip and add approximately 1-1/2-in (38mm) of leg length adjustment.

- a. Remove the footrest from the brackets by unscrewing the four button head screws (D) on the outside of the brackets.
- b. It is not necessary to remove the brackets from the telescoping tubes.
- c. Flip the footplate and reinstall the screws and nuts (E) so that they go through the hole and tighten up against the bracket. Tighten the mounting screws to 45 in-lbs (5 Nm) (do not overtighten)
- d. Repeat this procedure on the other side of the device.

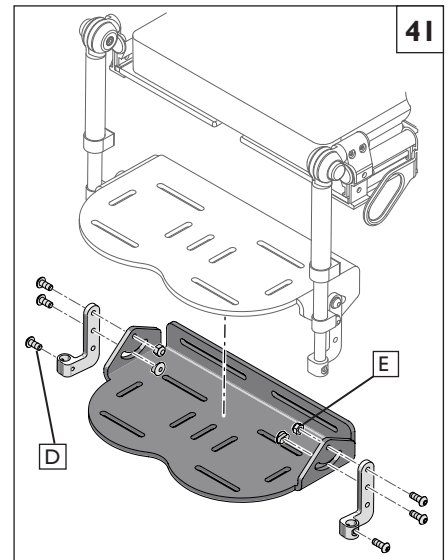

L. FOOTREST ADJUSTMENTS (MODERATE SEATING) 42 43

Height Adjustment

The height adjustment for the footrest consists of two telescoping tube sections which lock the footrest height.

- a. Identify adjustment screw locations (F) on the rear side of the footrest hanger.
- b. First loosen the screws on each side of the footrest hanger.
- c. Slide the footrest up or down to proper height.
- d. Tighten the to 15-20 in-lbs (1.7-2.6 Nm) (do not overtighten)
- e. For shorter range, remove four nuts (G & H) and move the footplate up.
- f. Tighten the adjustment hardware

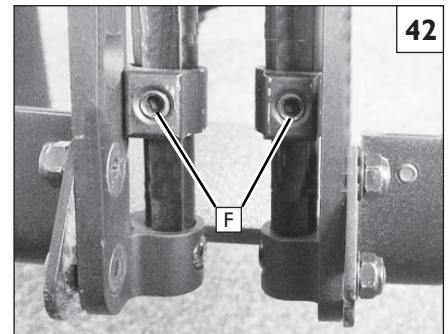

Angle Adjustment

- a. The footrest has two sets of hardware (G) and (H) that control footrest rotation. Loosen lower nuts and adjust the footrest to the preferred angle.
- b. Tighten the adjustment hardware to 40-45 in-lbs (4.5-5 Nm) to maintain proper footrest angle.

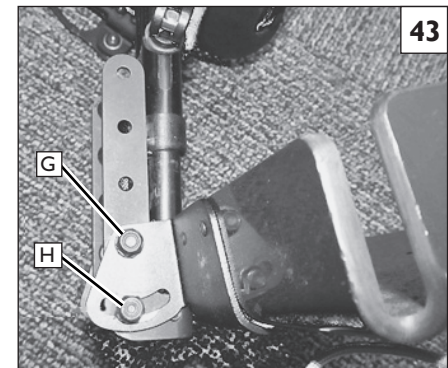

M. FLOOR TO SEAT HEIGHT ADJUSTMENT 44 45 46

The Voyage Stroller has three floor to seat height positions:

Low: 23-in (59cm), Med: 24.5-in (62.5cm),

and High: 26-in (66cm) Floor to Seat Adjustment

- a. Remove all four screws (A), two on each side of stroller.
- b. Position the cross bar tilt assembly to the desired height.
- c. Assemble again the four screws in the proper position indicated in the images to the right.
- d. Tighten the bolts to a torque of 75-85 in-lbs (8.5-9.6 Nm).

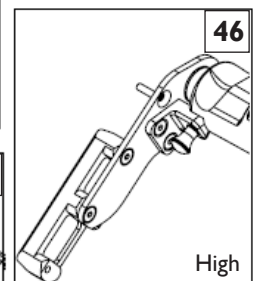
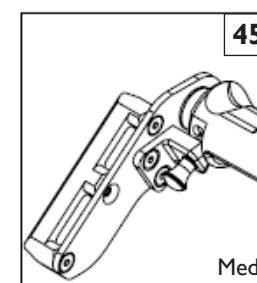
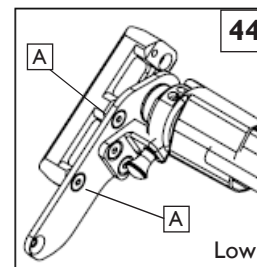

N. PELVIC POSITIONING BELT ATTACHMENTS/ADJUSTMENTS

Length Adjustment

- Remove any belt twists and place the belts outside of the seating area.
- Engage wheel locks, seat the child, and snap the pelvic positioning belt ends together.
- Adjust belt length to provide a snug fit. The adjuster is to the child's left.

Position Adjustment (Advanced Seating) 47

For the standard seat configuration the belt is always adjusted to the rear most point (approximately 45°). Use hardware shown (A). When the contour seat cushion is used, the belt may be adjusted forward to achieve an adjustment of up to 90°.

- Loosen the attachment screw (A) one or two turns to allow the belt anchor point to slide in the slot.
- Move the belt to the desired adjustment position
- Tighten the screw.

NOTE - Install the nylon web strap wraps under the tube, beside the seat base, and back over the top of the tube. This keeps the belt in the outer most position so it does not interfere with the seat cushion.

NOTE - When standard seat configuration is used, you must leave the belt in the rearmost position.

Position Adjustment (Moderate Seating) 48 49

For standard set-up the belt is always attached to the rear most point (approximately 45°), using hardware shown (B). If required, belt may be attached to either hip guide bracket (C) or to the positioning belt bracket (D).

4 Point Pelvic Positioning Belt Attachment (Moderate Seating) 49 50

For standard 4 point belt attachment use the rear most attachment point (B) and one of the holes (E) in either the hip guide (C) or positioning belt bracket (D).

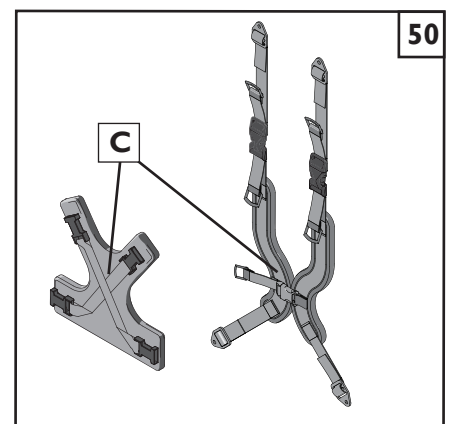
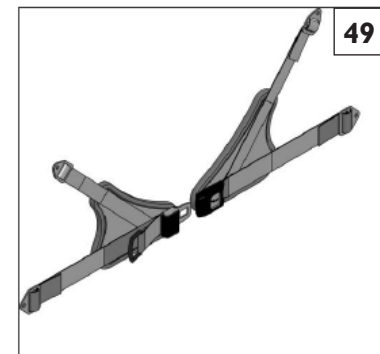
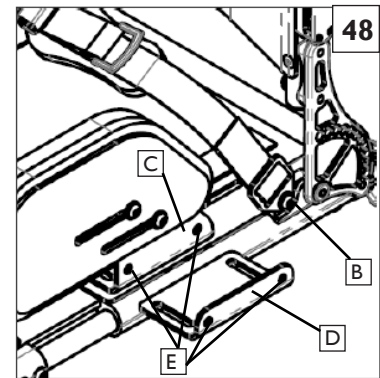
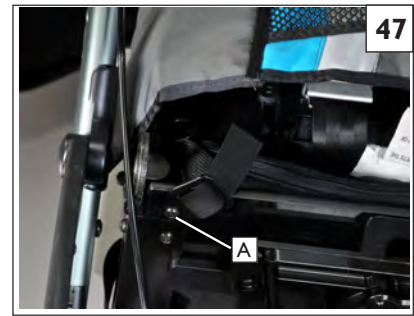

O. ANTERIOR TRUNK SUPPORT

WARNING

To avoid serious injury or issues with eating or breathing, the pelvic positioning belt is required to be used in combination with the butterfly harness. Double-check all adjustments to ensure there is no possibility of obstructing the airway or any other undesired constrictions. Do not use the butterfly harness without the pelvic positioning belt.

Harness Adjustment (Advanced Seating) 50

- Place the child in the seating system and fasten the pelvic positioning belt.
- Position the child's hips and tighten the belt to the proper position.
- Connect the butterfly harness (C) (two styles) to the straps already fastened to the positioning shell.
- First, adjust the lower butterfly straps to keep the butterfly from riding up on the child's torso.
- Then, adjust the upper straps making sure there is enough room around the child's neck for easy breathing and eating.
- Once the butterfly straps are adjusted, snap the lower straps into the plastic tri-glide up against the quick release buckle.

ANTERIOR TRUNK SUPPORT (Continued)

Harness Adjustment (Moderate Seating) 51 52

- a. Place the child in the seating system and fasten the pelvic positioning belt.
- b. Position the child's hips and tighten the belt to the proper position.
- c. Unlock the two lower cam locks (L) and the two upper cam locks (U).
- d. First, adjust the lower straps to keep the harness from riding up on the child's torso and lock lower cams (L).
- e. Then, adjust the upper straps making sure there is enough room around the child's neck for easy breathing and eating, and lock upper cams (U).

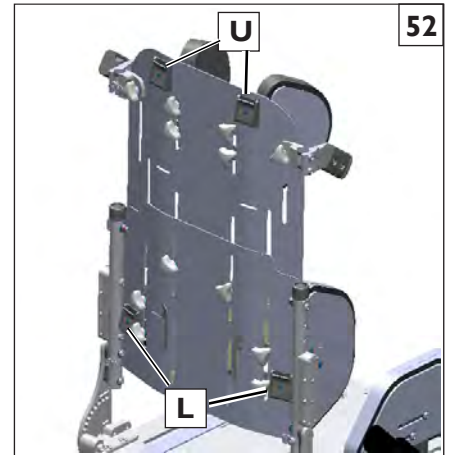
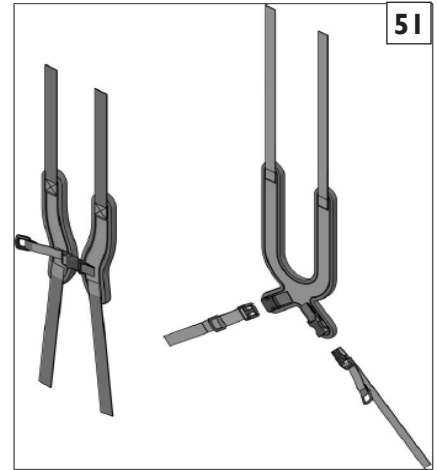

P. LATERAL TRUNK SUPPORTS (ADVANCED SEATING) 53

Assembly to the Seating Shell

- a. From behind your unit, unzip the back upholstery and remove the back pad to expose back shell.
- b. Insert screws and washers (A) from the rear of the shell through the adjustment slots.
- c. Thread the bolts into the lateral nut plate clamping the lateral mounting plate to the backshell.
- d. Tighten the screws.

Lateral Height and Width Adjustments 53

NOTE- The following adjustments may be able to be accomplished with the child present in the seating system.

- a. Unzip the rear cover to access the adjustment screws.
- b. **Loosen** (do not remove) the mounting screws (B) from the front of the shell enough to gain horizontal adjustment of the laterals. Adjust the lateral brackets for width bringing the lateral assembly including the pads to the proper position. If more horizontal adjustment is needed, you can also adjust the swing-away bracket.
- c. Tighten the mounting screws to hold the adjustment.
- d. To gain vertical adjustment of the laterals, loosen screws (A) from the rear of the back-shell, and move the laterals up or down to the proper position, and tighten the screws.

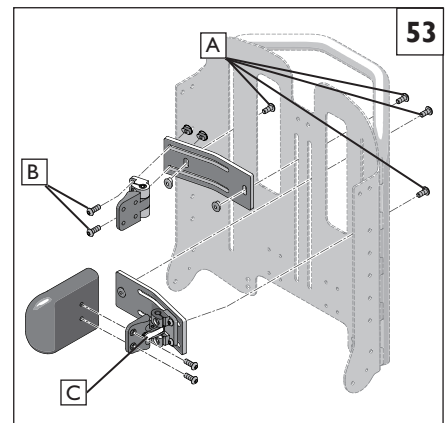

Lateral Length and Rotation Adjustments 54

- a. Slide the lateral cover and foam forward or remove to expose adjustment screws.
- b. Loosen screws (D) and move lateral to proper length, you can also add a slight rotation by twisting the lateral slightly. Be sure to make the same adjustment on the other side.
- c. Tighten screws and replace the foam and cover.

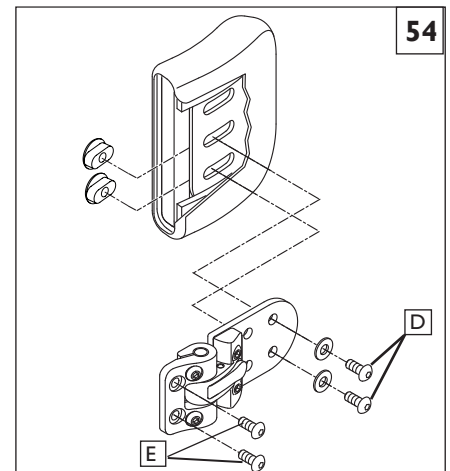

Lateral Swing-Away Operation 53

- a. Depress the silver lever (C) allowing the lateral to swing inwards or outwards. This is useful for storage or helping a child into or out of the seating system.

NOTE - The laterals lock into the adjusted preset position which can be angle adjusted by following steps in the next section "Lateral Angle Adjustment".

Lateral Angle Adjustment 54

- a. Lock the lateral by rotating inwards.
- b. Loosen the angle lock screw (E) as shown at the lateral hinge point.
- c. Adjust the lateral angle to the proper position and tighten.

Q. LATERAL TRUNK AND HEAD SUPPORTS (MODERATE SEATING) 55 56

This adjustment may be made with the user seated in the chair.

Lateral Height and Width Adjustment

- Loosen, or remove if necessary, the two knobs (F) from the rear of the shell enough to gain adjustment of the laterals.
- Use shell slots, (outer (G) or inner (H)) for height adjustment. Move the laterals up or down to the proper position and tighten the knobs.
- Use lateral bracket slots (I) for width adjustment or move from outer to inner shell slots. Adjust the lateral brackets for width bringing the lateral assembly to the proper position and tighten the knobs.

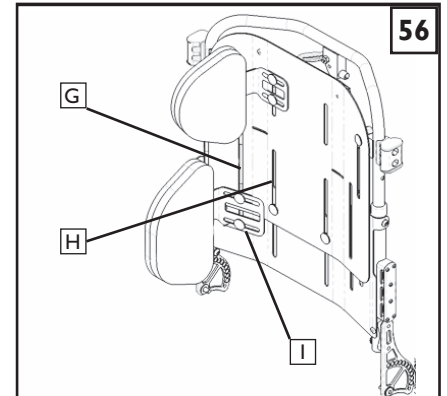
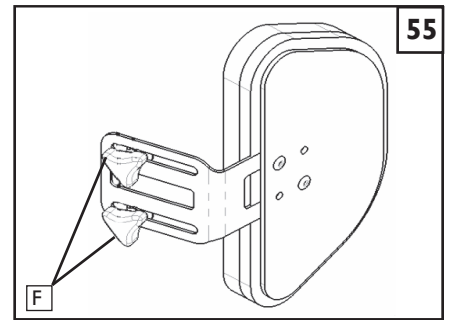

R. HIP GUIDES (MODERATE SEATING) 57 58

Width Adjustment

- Determine the proper location for each hip pad.
- Remove the seat cushion to expose hip pad adjustment screws(A).
- Loosen, or remove if necessary, two nuts under seat pan (B).
- Adjust hip pads to the desired position.
- Tighten the adjustment nuts (B) and replace the seat cushion.

Forward /Rear Pad Adjustment

- Determine the proper location for each hip pad.
- Remove the cover from the hip guide to expose hip pad adjustment screws.
- Loosen two adjustment screws (C).
- Adjust hip pads to the desired position.
- Tighten the adjustment screws (C) and replace the hip guide cover.

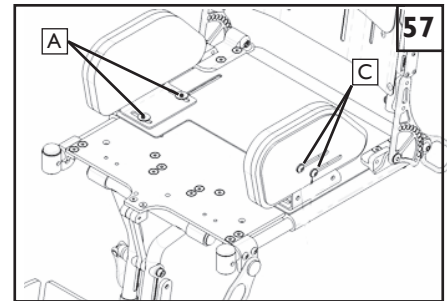

S. MEDIAL SUPPORT PAD (ADVANCED SEATING) 59

Medial support pads are optional equipment available only with the optional contoured seating system.

Angle and Width Adjustment

- Locate medial adjustment screw. (D) Screw is located beneath the forward edge of the seat. Note: The receiver assembly plate will need to be partially loosened and moved.
- Lock the wheels, seat the child, and buckle the pelvic positioning belt.
- Loosen the adjustment screw from beneath the seat and adjust medial pad to proper width and angle.
- Tighten adjustment screw to lock the medial position.

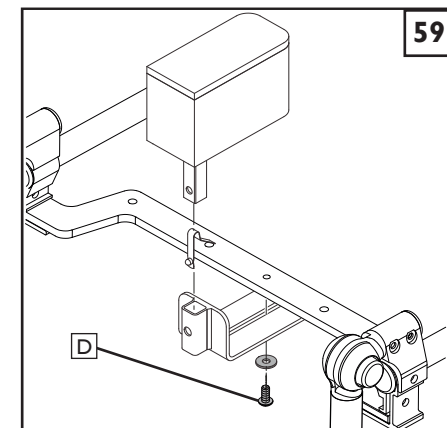
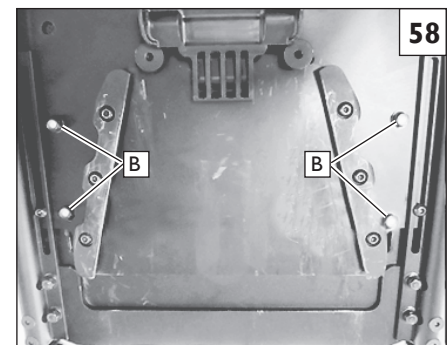

T. MEDIAL SUPPORT PAD (MODERATE SEATING) 60 61

Medial pad assembly

- a. Raise the footrest up so that it is horizontal with the seat pan.
- b. Find the two holes (E) in the seat pan, located on both sides of the footrest tube.
- c. Seat cushion must be attached.
- d. Slide the metal bracket through the slot in the cushion and align holes in the bracket with the holes in the seat pan.
- e. Attach the Medial pad (F) to the seat pan with hardware (G).

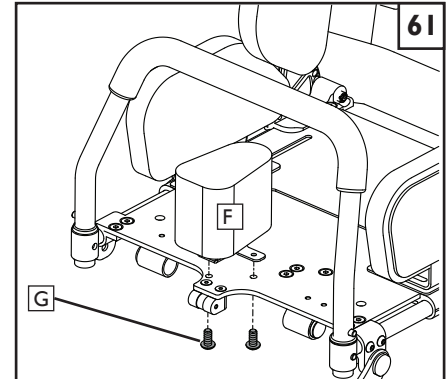
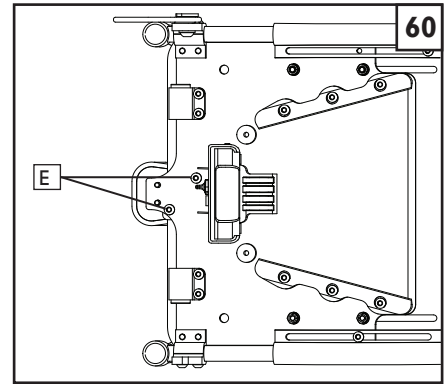

U. ANTERIOR SUPPORTS

When deciding if you should use Anterior supports, always consult your healthcare advisor.

Some children, due to their disability level or physical condition, may need anterior supports to help maintain proper posture or body position. Such devices include head straps, shoulder straps, thoracic strap systems, pelvic supports, and belts.



Risks of injury with head supports and how to avoid them.

Excess movement or migration of the pelvis- This may cause the supports to displace. If this occurs, severe injury to the child could result.

To avoid risks:

1. It is VITAL to keep the child in a stable pelvic position.
2. Anterior supports should ONLY be used with seat, back, and pelvic supports or belts that keep the child from sliding down in the seat.
3. Anterior supports must be fitted by your authorized dealer and your healthcare professional.
4. After fitting, anterior supports, they should ONLY be placed and adjusted by trained professionals.
5. DO NOT leave the child unattended when using anterior supports.

V. HEADSUPPORTS(Optional) (ADVANCED SEATING) 62 63 64

Attaching Head Support in Lower Positions

- a. Remove back cushion and unsnap rear shell upholstery exposing two head support mounting holes at center back of inner seating shell.
- b. Insert t-nut (C) from inside of shell attaching headrest mount with supplied screws.
- c. Tighten the hardware securely.

Head Support Adjustment & Higher Position Mounting

- a. You can adjust height of the headrest with the height adjustment screws (A).
- b. You can adjust anterior/posterior depth, by loosening the adjustment screws (B).
- c. You can adjust the pad tilt and angle by adjusting the collar, and collar bolts.
- d. To raise the headrest to a higher position you can invert the bracket (D) as shown in (Figure 61).

Attaching Headrest Pad

- a. Remove vinyl collar cover and insert over the knurled headrest ball.
- b. Loosen collar screws (E) enough to slip collar onto knurled ball.
- c. Be sure to evenly tighten the collar by first loosely starting the screws.
- d. Using the 5/32-in hex key, tighten the screws 1/2 turn alternating between the two sides until there is an even gap as shown (F). Make sure collar alignment is even and secure. If collar is unevenly tightened as shown (G), injury to the child could result.

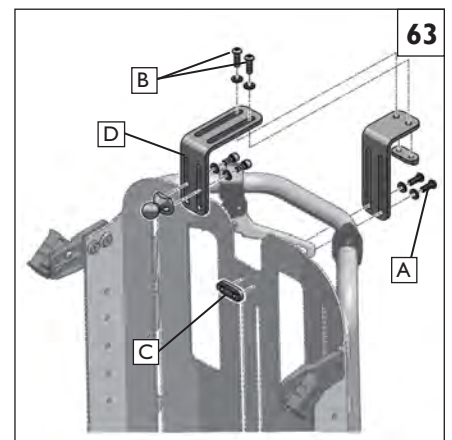

HEADREST SUPPORTS (Continued)

Forehead Strap Adjustment 65

- a. Using an Allen wrench: Loosen the guide rods adjustment screws (H) and slide both guide rods evenly to desired diameter.
- b. Locate neoprene strap in desired position on forehead.
- c. Slide guide rods through clamp until front of neoprene strap is approximately 1/2-in (12.7mm) from plastic guide support. Strap must fit snugly on forehead.
- d. Tighten again guide rod adjustment screw (H) to hold position.
- e. Guide rods may be trimmed to 1-in (25.4mm) limiting rearward protrusion. Vinyl caps should be removed prior to trimming and then assembled again.
- f. Adjust again forehead strap as necessary.

Headrest Downward Stop Angle Adjustment 65

- a. Using an Allen wrench loosen the angle adjustment clamp screws (I)
- b. Insert an Allen wrench into the exposed hole on the silver angle adjustment pivot (J) and rotate until the forehead pad and guide rods are at the desired angle.
- c. Tighten again the angle adjustment clamp screws and check all settings.

NOTICE— Fasteners and DFS2 adjustment should be checked prior to each use. Neoprene Strap must be replaced at the first signs of wear or loss of tension. Please refer to Headstrap instruction sheet on the website or in your kit.

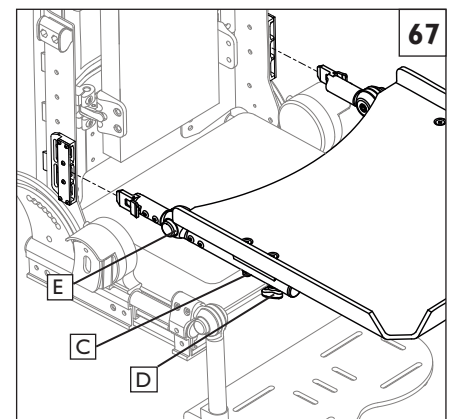
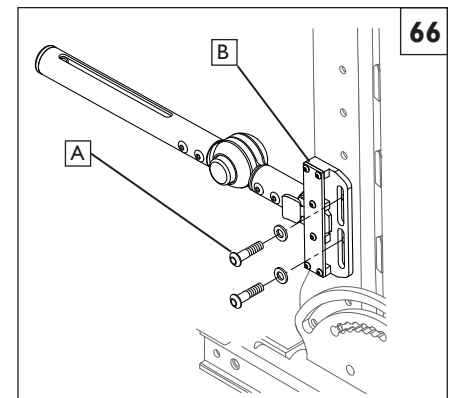
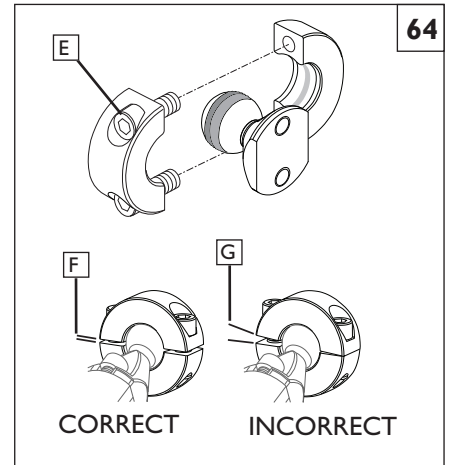

W. TRAY ARM HEIGHT ADJUSTMENT (ADVANCED SEATING) 66

- a. Loosen or remove the two button head screws (A) to raise or lower the tray support arm receiver bracket (B).
- b. Adjust tray support receiver bracket to the proper height and tighten the screws.
- c. Insert the tray arm into one of 3 possible height positions on the receiver bracket.
- d. Repeat the procedure for opposite side making sure tray supports are equal in height adjustment so that the tray can be assembled easily.

X. TRAY ASSEMBLY AND ADJUSTMENT 67

- a. Slide the tray over the tray supports, adjust depth and click into place.
- b. Check that nut (C) is just loose enough so that the tray can be adjusted.
- c. Knob (D) is loosened to adjust the depth of the tray and tightened on both sides to hold the adjustment.
- d. Adjust the angle of the tray by holding in both knuckle buttons (E) on the support arms and raising the tray to desired angle, the tray should click in place for a positive lock.

⚠ WARNING

Using a pelvic positioning belt is critical for child safety when foot straps or shoe holders must be used for therapeutic positioning needs.

Y. SHOE HOLDER FOOT STRAP ADJUSTMENT (Option) 68

NOTE - Shoe holders and optional foot straps are intended for therapeutic positioning needs only.

- a. Engage the wheel locks and seat the child.
- b. Loosen the shoe holder straps (F)
- c. Child should be wearing shoes for this step. Place child's foot into shoe holder and snap the two shoe holder straps into place.
- d. Keep the straps as loose as possible and only tighten enough to maintain a therapeutic position.

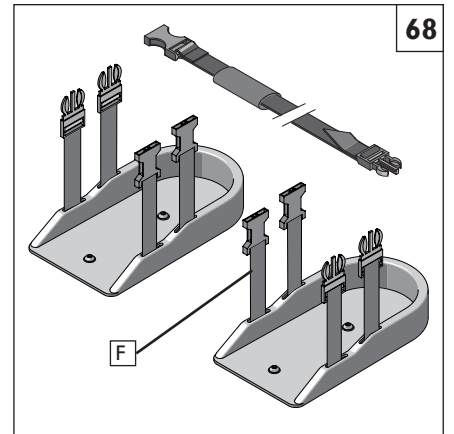

Z. VENT/BATTERY TRAYS (OPTIONAL) 69

- a. There are two types of vent platforms. A rear mount or dovetail vent mount (A) which has a weight capacity of 15lbs (6.8kg), and an under frame vent and battery tray (B) which has a weight capacity of 50lbs (22.7kg).
- b. The platforms attach easily to the Voyage base frame.
- c. Tie down straps are included with these options to secure the equipment.

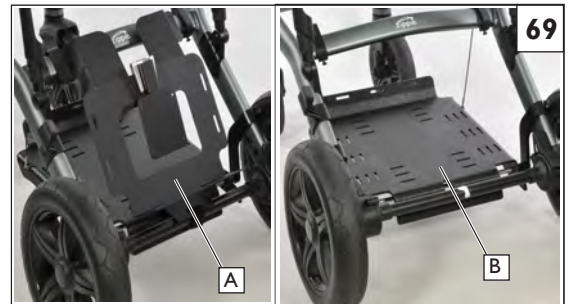

AA. FRONT OR REAR ADD-ON PLATFORM (Option) 70 71

1. The rear platform (C) can be used for support of a vent, or other equipment that might be needed.
2. The front mount utility platform (D) has a weight limit of 50 lbs (22.7 kg).
3. Tie down straps are included with this option to secure the equipment.

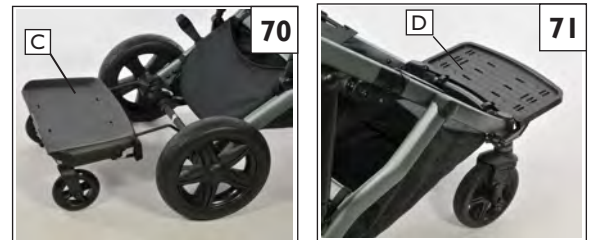

AB. IV SUPPORT POLE / O2 TANK HOLDER (Option) 72 73

1. IV pole (E) and Oxygen holder (F) are both fully adjustable and attach directly to your Voyage base frame as shown in Figure 73.

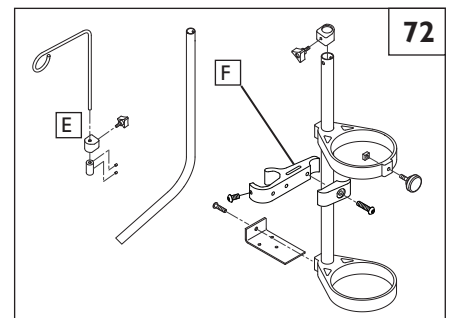

A. FOR FIVE (5) YEARS

Sunrise Medical warrants the Zippie Voyage frame against defects in materials and workmanship for the lifetime of the product. Lifetime is defined as 5 years.

B. FOR ONE (1) YEAR

We warrant all components against defects in materials and workmanship for one year from the date of first consumer purchase. An invoice, as proof of purchase, may be required.

C. LIMITATIONS

1. We do not warrant:
 - a. Tires and tubes, upholstery, pads and push handle grips.
 - b. Damage from neglect, accident, misuse, or from improper installation or repair.
 - c. Products modified without Sunrise Medical's express written consent.
 - d. Damage from exceeding the weight limit.
2. This warranty is VOID if the original chair serial number tag is removed or altered.
3. This warranty applies in the USA and Canada only. Check with your dealer to find out if international warranties apply.
4. This warranty is not transferable and only applies to the first consumer purchase of this wheelchair through an authorized Sunrise Medical dealer.

D. WHAT WE WILL DO

Our sole liability is to repair or replace covered parts. This is the exclusive remedy for consequential damages.

E. WHAT AUTHORIZED DEALER MUST DO –

1. Obtain from Sunrise Medical, while this warranty is in effect, prior approval for return or repair of covered parts. Contact Customer Service for a Returned Material Authorization (RMA) number and information as to where to return the product.

F. NOTICE TO CONSUMER –

1. You must pay the cost of labor to repair, remove or install parts even if they are covered under warranty.
2. If allowed by law, this warranty is in place of any other warranty (written or oral, express or implied, including a warranty of merchantability, or fitness for a particular purpose).
3. This warranty gives you certain legal rights. You may also have other rights that vary from state to state or province to province.

G. ADDITIONAL WARRANTY INFORMATION

For goods provided by Sunrise Medical Pty Ltd in Australia, our goods come with a guarantee by Sunrise that cannot be excluded under the Australian Consumer Law. You are entitled to a replacement or refund for a major failure and for compensation for any other reasonably foreseeable loss or damage. You are also entitled to have the goods repaired or replaced if the goods fail to be of acceptable quality and the failure does not amount to a major failure. The benefits to you given by this warranty are in addition to your other rights and remedies under a law in relation to the goods to which the warranty relates.

Record your serial number here for future reference:





Sunrise Medical • 2842 Business Park Ave. • Fresno, CA 93727 • USA
In Canada (800) 263-3390



Customer Service: 800.333.4000
www.SunriseMedical.com

©2020 Sunrise Medical (US) LLC
07/20 245797 Rev. B