



SEDEO ERGO SEATING SYSTEM

Quickie® Sedeo Ergo Seating System

Supplier: This manual must be given to the user of this wheelchair.

User: Before using this wheelchair read this entire manual and save for future reference.

Owner's Manual

Quickie® Sedeo Ergo Seating System

Distribuidor: Este manual debe ser entregado al pasajero de esta silla de ruedas.

Pasajero: Antes de usar esta silla de ruedas, lea este manual en su totalidad y guárdelo para futura referencia.

Cada una de las sillas se envía con un manual de instrucciones en inglés. El manual en español o francés está disponible en formato PDF en nuestra página en Internet: www.SunriseMedical.com. Ingrese a la página del producto específico para descargar el manual, o comuníquese con el proveedor autorizado de Sunrise Medical.

Manual de Instrucciones

Quickie® Sedeo Ergo Seating System

Fournisseur: Ce manuel doit être remis à l'utilisateur / utilisatrice de ce fauteuil roulant.

Utilisateur / Utilisatrice: Avant d'utiliser ce fauteuil roulant, lisez entièrement ce manuel et conservez le pour le consulter ultérieurement.

Chaque fauteuil est livré avec un manuel d'instructions en anglais. Les versions en espagnol et en français sont à votre disposition en format PDF sur le site: www.SunriseMedical.com. Veuillez vous rendre à la page de votre produit pour télécharger le manuel dans la langue souhaitée, ou contactez un fournisseur agréé Sunrise Medical.

Mode d'emploi



SUNRISE LISTENS

Thank you for choosing a Quickie Seating System. We want to hear your questions or comments about this manual, the safety and reliability of your system, and the service you receive from your Authorized Dealer. Please feel free to write or call us at the address and telephone number below:

Sunrise Medical (US) LLC
Customer Service Department
2842 Business Park Ave
Fresno, CA 93727
(800) 333-4000

FOR ANSWERS TO YOUR QUESTIONS

Your Authorized Dealer knows your wheelchair best, and can answer most of your questions about system safety, use and maintenance. For future reference, fill in the following:

Supplier: _____

Address: _____

Telephone: _____

Serial #: _____ Date/Purchased: _____

INFORMATION YOU SHOULD KNOW

No component of this system was made with Natural Rubber Latex.



DISPOSAL AND RECYCLING INFORMATION

When this product reaches the end of its life, please take it to an approved collection or recycling point designated by your local or state government. This Seating system is manufactured using a variety of materials. Your product should not be disposed of as ordinary household waste. You should dispose of your system properly, according to local laws and regulations. Most materials that are used in the construction of this product are fully recyclable. The separate collection and recycling of your product at the time of disposal will help conserve natural resources and ensure that it is disposed in a manner that protects the environment.

Ensure you are the legal owner of the product prior to arranging for the product disposal in accordance with the above recommendations.

USER WARNING



Attention seating system users, do not operate this device without first reading this owner's manual. If you do not understand the instructions and warnings of this owner's manual please contact your Authorized Dealer before operating this Quickie seating system. Failure to do so may result in damage and/or injury.

DEALER/TECHNICIAN WARNING



Attention dealers and qualified technicians, do not operate or service this seating system without first reading this owners manual. If you do not understand the instructions and warnings of this owners manual please contact the Quickie Technical Service Department before operating and/or servicing this Quickie seating system. Failure to do so may result in damage and/or injury.

ELECTROSTATIC DISCHARGE



Power seating system have printed circuit boards. Careful attention should be given to printed circuit board handling techniques to avoid damaging the control, and/or drive electronics of the system, this could create a safety hazard. Do not expose or remove printed circuit boards. Contact your Authorized Dealer for help with any electronics issues.

Related Documents

Listed below are additional documents which are referenced in this owners manual.

- QM-710/715HD/720 Owners Manual
- QM-710/715HD/720 Service Manual

I. INTRODUCTION.....	2	VIII. USE AND MAINTENANCE.....	13
II. TABLE OF CONTENTS	3	A. Introduction.....	13
III. YOUR SYSTEM AND ITS PARTS.....	4	B. Cleaning.....	13
IV. NOTICE– READ BEFORE USE.....	5	C. Storage Tips.....	13
V. EMI (ELECTROMAGNETIC INTERFERENCE).....	5	D. Ordering Parts	13
A. What is EMI?.....	5	E. Safety Checklist.....	13
B. What effect can EMI have?.....	5	F. Flip-Back Cantilever armrests	14
C. Sources of EMI	5	G. Lift-off Bolster Pad	14
D. Distance from the Source	6	H. Swing-away, Length adjust, and Midline Joystick Mounts..	14
E. Immunity Level.....	6	I. Headrest Height and Depth adjustment	15
F. Report all suspected EMI incidents.....	6	J. Check-out	15
G. EMI from System	6	IX. CONTROLS, JOYSTICKS & OPERATING GUIDES	16
H. Head Array Safety and RFI.....	6	A. Controls	16
VI. GENERAL WARNINGS.....	7	B. Connectors.....	16
A. Weight Limit.....	7	C. R-NET Joysticks	16
B. Notice to User and Attendants.....	7	D. Joystick Buttons and Controls (Color).....	17
C. Controller Settings.....	7	E. Joystick Buttons and Controls (Advanced).....	17
D. Safety Check List.....	7	F. LCD Screen (color and advanced).....	18
E. Changes and Adjustments	8	G. Joystick Stationary.....	20
F. Accessories	8	H. Thermal Roll-back.....	20
G. When Seated in a Parked Wheelchair	8	I. Power Recline, Tilt & Lift Operation	20
H. When Seated and Driving in Lift mode	8	J. Setting Seat Memory Position	20
I. To Reduce The Risk Of A Fall, Tip-Over Or Loss Of Control	8	K. Pressure Relief Alert and Recording	21
J. Environmental Conditions.....	8	L. Selected Sound Mute.....	21
K. Center of Balance.....	9	X. DEALER SERVICE AND ADJUSTMENT	23
L. Transfers.....	9	A. Dealer Service Introduction	23
M. Wheelchair Lifts.....	9	B. Critical Maintenance Tips	23
N. Driving in low-light or at night.....	9	C. Cleaning.....	23
VII. WARNINGS: COMPONENTS & OPTIONS.....	10	D. Adjustment Notes.....	23
A. Armrests.....	10	E. Flip-back Armrests.....	24
B. Cushions	10	F. Adjusting the Seat Plate width	25
C. Fasteners	10	G. Adjusting the Back Plate width	25
D. Footplate and Footrests	10	H. Adjusting Seat depth.....	25
E. Positioning Belts (Optional).....	10	I. Seat-to-Floor height.....	26
F. Push Handles	10	J. Legrests and Footplates (Power Center Mount)	26
G. Seating Systems.....	10	K. Headrest height, angle and depth adjustment.....	27
H. Upholstery fabric.....	10	L. Headrest Offset adjustment	27
I. Wiring & Connectors	10	M. Retractable Joystick Mount.....	27
J. Assignable Controls.....	11	N. Midline Joystick Mount.....	27
K. Power Seating safety.....	11	O. Front Lighting Adjustment	28
L. Power Recline.....	11	P. Performance Control Settings	28
M. Power Legrest Accessory	11	Q. Ctrl + 5 Assignable Buttons	28
N. Lift or Lift/Tilt Combo	11	R. On board programmer or DTT (Diagnostic test tool) or R-Net PC Programmer	28
O. Swing-away Joystick Arm	11	XII. SUNRISE LIMITED WARRANTY.....	29
P. Transit.....	12		

III. YOUR SYSTEM AND ITS PARTS



1. Recline Seating
2. Cantilever armrest
3. Tilt/Lift module
4. Foot Plate
5. Power Center Mount
6. Sedeo seating
7. Armrest Pad
8. Sedeo Back Support
9. Headrest

All features may not be available with some system setups or in conjunction with another system feature. Please consult your supplier for more information. Your authorized supplier can also provide you with more information on accessories.

QUICKIE SEDEO ERGO

Weight with group 34 batteries (in lbs)

	Tilt/Lift	Tilt only
Complete system:	430	400
Seating system:	150	150

Weight Capacity

300lbs (136kg)- Tilt & Lift
350lbs (160kg)- HD Tilt only

Joystick

Option - RNET- Color w/Lights.
Option - Joystick Advanced - Color display, paddle switches, Infrared Output, programmable buttons, Stereo Jacks.

Highlight Colors

Red, Black, Blue, White, Orange, and Green.

Seats, Upholstery and Style

Standard MPC:
Power Recline
Sizes: 16" - 22" wide, 16" - 22" deep

Footrest:

Standard- Fixed Center Mount
Option- Power Center Mount.

Backrest

MPC: Recline

Backrest Upholstery and Style

Standard: 3DX
Option: 3DX with X-static silver thread and stretch outer cover.
Option: Premium leatherette with perforated inserts.

Armrest

MPC: Waterfall reclining
Option- Comfort reclining (Foam)
Option- Comfort reclining (Gel)
Option- AES Trough Elbow block reclining armpads.

Suspension

Spider Trac 2.0

A. CHOOSE THE RIGHT DEVICE /SAFETY OPTIONS

Sunrise provides a choice of many power wheelchair styles, sizes and adjustments to meet the needs of the user. However, final selection of a wheelchair rests solely with you and your health care professional. Choosing the best system for you depends on such things as:

1. Your size, disability, strength, balance and coordination.
2. Your intended use, and your level of activity.
3. The types of hazards you must overcome in daily use (in areas where you are likely to use your system).
4. The need for options for your safety and comfort (such as positioning belts or special seat systems).

INTENDED USE: The Quickie Sedeo Ergo Seating system is a battery operated device that is intended for medical purposes to provide mobility and postural support to persons restricted to a sitting position.

B. ADJUST SYSTEM TO YOUR ABILITY

You need to work with your doctor, nurse or therapist, and your Authorized Dealer, to fit this system and adjust the controller settings for your level of function and ability.

C. REVIEW THIS MANUAL OFTEN

Before using this system you, and each person who may assist you, should read this entire Manual and make sure to follow all instructions. Review the warnings often, until they are second nature to you.

D. WARNINGS

The word “WARNING” refers to a hazard or unsafe practice that may cause severe injury or death to you or to other persons. The “Warnings” are in four main sections, as follows:

1. V — EMI

Here you will learn about electromagnetic interference and how it can affect your system.

2. VI — GENERAL WARNINGS

Here you will find a safety checklist and a summary of risks you need to be aware of before you ride this system.

3. VII — WARNINGS — COMPONENTS & OPTIONS

Here you will learn about your seating system. Consult your authorized dealer and your health care professional to help you choose the best set-up and options for your safety.

Throughout this owner’s manual and on the wheelchair you will see the icons listed below to identify warnings and potential hazards.



WARNING!

These warnings must be followed, failure to do so may cause personal injury or may damage the wheelchair.



ESD:

Electrostatic Discharge can damage printed circuit boards.

V. EMI (ELECTROMAGNETIC INTERFERENCE)



WARNING

Heed all warnings to reduce the risk of unintended brake release or system movement:

1. **Beware of the danger from hand-held transceivers. Never turn on or use a hand-held transceiver while power to your seating system is on. Use extra care if you believe that such a device may be in use near your chair.**
2. **Be aware of nearby radio or TV stations, and avoid coming close to them.**
3. **If unintended movement occurs, turn your chair off as soon as it is safe to do so.**

A. WHAT IS EMI?



WARNING

1. EMI means: electromagnetic (EM) interference (I). EMI comes from radio wave sources such as radio transmitters and transceivers. (A “transceiver” is a device that both sends and receives radio wave signals).
2. There are a number of sources of intense EMI in your daily environment. Some of these are obvious and easy to avoid. Others are not, and you may not be able to avoid them.
3. Powered wheelchairs may be susceptible to electromagnetic interference (EMI) emitted from sources such as radio stations, TV stations, amateur radio (HAM) transmitters, two way radios, and cellular phones.
4. EMI can also be produced by conducted sources or electrostatic discharge (ESD).

B. WHAT EFFECT CAN EMI HAVE?



WARNING

1. EMI can cause your chair, without warning, to:
 - Release its brakes
 - Move by itself
 - Move in unintended directions
 If any of these occur, it could result in severe injury to you or others.
2. EMI can damage the control system of your chair. This could create a safety hazard, and lead to costly repairs.

C. SOURCES OF EMI



WARNING

The sources of EMI fall into three broad types:

1. **Hand-Held Transceivers:**

The antenna is usually mounted directly on the unit. These include:

- Citizens band (CB) radios
- “Walkie-talkies”
- Security, fire and police radios
- Mobile phones
- Lap-top computers with phone or fax
- Other personal communication devices
- Electronic article surveillance systems

NOTE – These devices can transmit signals while they are on, even if not in use.

2. Medium-Range Mobile Transceivers:

These include two-way radios used in police cars, fire trucks, ambulances, and taxi cabs. The antenna is usually mounted on the outside of the vehicle.

3. Long-Range Transceivers:

These include commercial radio and TV broadcast antenna towers and amateur (HAM) radios.

NOTE– The following are not likely to cause EMI problems: Laptop computers (without phone or fax), Cordless phones, TV sets or AM/FM radios, CD or tape players.

D. DISTANCE FROM THE SOURCE

WARNING

Electro-magnetic energy rapidly becomes more intense as you get closer to the source. For this reason, EMI from hand-held devices is of special concern. (See Section C.1) A person using one of these devices can bring high levels of EM energy very close to your system without you knowing it.

E. IMMUNITY LEVEL

WARNING

1. The level of EM is measured in volts per meter (V/m). Every power seating system can resist EMI up to a certain level. This is called its “immunity level”.
2. The higher the immunity level, the less the risk of EMI. It is believed that a 20 V/m immunity level will protect the power seating system user from the more common sources of radio waves.
3. The common configuration tested and found to be immune to at least 20 V/m is: Sedeo Ergo power seating system with a right-hand mounted RNET remote joystick system, 18" seat width, 18" seat depth, Omni specialty control module, power recline seat, cantilever armrests, power tilt/lift, centermount powered legrests, attendant module, bluetooth mousemover, I-device mousemover, output module, Gp 24 gel cell batteries.
4. All After Market input device options, classified as breath controls, Proportional controls, and/or Switched controls that can be used with this powerchair, have an unknown effect on their immunity level to different types of EMI. They have not been specifically tested with the QM-710/715HD/720 and RNET control system:
5. All modifications required for the common configuration to comply with ANSI/RESNA WC2/21 have been installed

WARNING

If there is any doubt that the specialty control input device is not immune to 20V/m, extra care should be taken around known sources of EMI.

WARNING

There is no way to know the effect on EMI if you add accessories or modify this system. Any change to your system may increase the risk of EMI. Parts not specifically tested or parts from other suppliers have unknown EMI properties.

F. REPORT ALL SUSPECTED EMI INCIDENTS

WARNING

You should promptly report any unintended movement or brake release. Be sure to indicate whether there was a radio wave source near your system at the time. Contact:

Sunrise Medical, Customer Service Department at (800) 333-4000.

G. EMI FROM SYSTEM

WARNING

The system itself can disturb the performance of electromagnetic fields such as emitted by alarm systems of shops.

H. HEAD ARRAY SAFETY AND RFI

WARNING

If you have a Head-array, the sensors used in the product have the potential to operate unintentionally if moisture or any substance that is electrically conductive is present in sufficient quantities.

Electro magnetic interference from electrical power lines and certain types of phones can cause the sensors to activate.

These sensors are capacitive in nature, and can generate an electronic field, which can be affected by liquids and/or a source of radio frequency Interference (RFI). Any material that is conductive has the potential to activate the Head-array unintentionally.

Avoid use under high power lines and around cell phones.

Avoid the use of a Head Array in rain or snow and protect against the potential of spilled liquids on the sensors.

Avoid cell phones and electronic devices in proximity to the array.

Avoid any source that has the potential of (RFI).

Warn the user of this system that the system controls have the potential of acting erratically or making sudden stops, if (RFI) is not avoided.

If any (RFI) causes erratic behavior, immediately cut off the power to the seating system, and wait until the interference passes.

⚠ WARNING

Heed all warnings in this section. If you fail to do so, a fall, tip-over or loss of control may occur and cause severe injury to you or others.

A. WEIGHT LIMIT**⚠ WARNING**

NEVER exceed the weight limit.

300 pounds (136 kg) (Tilt & Lift)

350 pounds (160 kg) (Tilt Only)

If the limit is exceeded, damage to your device, a fall, tip-over or loss of control may occur and cause severe injury to the rider and/or others.

1. The user plus items carried should never exceed the total weight capacity identified on your system.
2. Never use this system for weight training.
3. Exceeding the weight limit is likely to damage the seat, frame, or fasteners, and may cause severe injury to you or others from system failure.
4. Exceeding the weight limit will void the warranty.

B. NOTICE TO USER AND ATTENDANTS**⚠ WARNING****User:**

1. Before using this system, you should be trained in its safe use by your health care professional.
2. Every seating system is different. Take the time to learn the feel of this system before you begin riding.
3. Be aware that you must develop your own methods for the safe use of this system that are best suited to your level of function and ability.
4. Have someone help you practice bending, reaching and transfers until you learn how to do them safely.
5. Never try a new maneuver on your own unless you are sure it is safe.
6. Get to know the areas where you plan to use your system. Look for hazards and learn how to avoid them.
7. Always wear a positioning strap.
8. Do not use a seating system if the joystick does not spring back to the neutral position.
9. Do not use your seating system if the joystick boot is ripped or damaged.
10. Do not try to tip this seating system without an attendant present.
11. Do not allow additional riders, the system may become unstable.

User and Attendants:

1. When transferring the user in or out of the seating system never use the footplate as a platform.
2. Do not lift this seating system by any parts that are removable, doing so may result in damage to the seating system or injury to the user.
3. Never try to stop or slow this seating system with the wheel locks (if applicable). Wheel locks are designed to prevent the system from moving when stopped. They are not brakes.
4. Always keep your hands and body parts clear of moving parts to help prevent injuries.

⚠ WARNING**Attendants:**

Make sure you heed all warnings and follow all instructions in each section of this manual. Warnings that apply to the user also apply to you.

1. Do not stand or sit on any portion of this seating system.
2. You need to work with the user, and the user's doctor, nurse or therapist, to develop safe methods best suited to your abilities and those of the user.
3. To manually push the system you must release the motor brakes.
 - Do not engage or disengage motor brakes **unless** power to the system is **off**.
 - Make sure you have full control over the system when you release the motor brakes. When you do so the system will not have brakes.
 - Make sure the system is on level ground before you release the motor brakes.
4. Propel this system by the push handles only. They provide secure points for you to hold the rear of the system to prevent a fall or tip-over.
5. Check to make sure push handle grips will not rotate or slip off.

Attendant control:**⚠ WARNING**

Make sure you always have comfortable access to the controls while the chair is moving and make sure that the controller is fixed securely to the chair.

1. Set the speed of the attendant control to a speed that you can comfortably follow.
2. Always turn off the power to the controller when leaving the user in the chair.

C. CONTROLLER SETTINGS**⚠ WARNING**

Be aware that you may need to adjust the controller settings of your system.

1. Check and adjust the settings every six to twelve months.
2. Consult your authorized dealer to adjust the control settings immediately if you notice any change in your ability to:
 - Control the joystick
 - Hold your torso erect
 - Avoid running into objects.

D. SAFETY CHECK-LIST**⚠ WARNING**

Before each use of this system:

1. Make sure the system operates smoothly. Check for noise, vibration, or a change in ease of use. (These may indicate loose fasteners, or damage to your system).
 - Inspect any problem. Your authorized dealer can help you find and correct the problem.
2. Make sure batteries are charged. Green lights on charge indicator will light up when charge is full. Yellow lights indicate battery charge level is getting low. Red lights indicate batteries are in immediate need of charging.

E. CHANGES & ADJUSTMENTS

WARNING

Never use non-Quickie parts to replace Quickie parts or make changes to your system unless authorized by Sunrise. (Doing so will void the warranty and may create a safety hazard.)

F. ACCESSORIES

WARNING

Accessories designed by manufacturers other than Sunrise, not available through Sunrise order process have not been tested or approved for use by Sunrise.

1. If you modify or adjust this system it may increase the risk of a fall or tip-over.
2. Modifications unauthorized by Sunrise constitutes remanufacturing of the seating system. This voids the warranty. The user then assumes all future liability for the seating system.

G. WHEN SEATED IN A PARKED WHEELCHAIR

WARNING

1. **Always** turn off all power to your system when you are parked, even for a moment. This will prevent:
 - Accidental movement from contact with the joystick by you or others.
 - Unintended brake release or movement from EMI sources. (See Section V)
2. Make sure that persons who help you are aware of the joystick and do not touch it. If they do, your system may move suddenly when you do not expect it.

H. WHEN SEATED AND DRIVING IN LIFT MODE

WARNING

Your chair may be configured with a Power Seat Lift. Before operating your chair in Lift mode, read all warnings and guidelines related to this feature. They will help in understanding how to reduce the risk of a fall or tip-over, and how to identify environmental conditions that could effect your safety when driving while the seat lift is operated.

NEVER exceed the weight limit of 300 pounds (136 kg) (See section A- Weight limits).

1. When driving indoors, or outdoors, the lift mode should only be used on flat, level, and hardscape surfaces.
2. Driving in lift mode should never be attempted outdoors on uneven terrain like: gravel, grass, bumpy surfaces, uneven sidewalks, or hills.
3. This feature may be equipped with a system that allows the power chair to drive up to 3mph when the seat is elevated.
4. NEVER raise the seat when the chair is being operated in the proximity of any of the terrain types listed above, or on any uneven surface.

I. TO REDUCE THE RISK OF A FALL, TIP-OVER OR LOSS OF CONTROL

WARNING

1. **Never** use your system on a slope unless you are sure you can do so without losing traction, or tipping over.
2. **Always** go as straight up and as straight down as you can.
 - **Do not** “cut the corner” on a slope or ramp.
 - **Do not** turn or change direction on a slope.
3. **Always** stay in the center of the ramp. The ramp needs to be wide enough so that the wheel won't roll off of the side of the ramp.
4. Keep your chair moving at a slow, steady speed. Keep control over the chair at all times.
 - On a descent, do not let your chair accelerate beyond its normal speed.
 - If the chair picks up speed, center the joystick to slow down or stop.
 - If you stop, re-start slowly

J. ENVIRONMENTAL CONDITIONS



WARNING

Your system is not designed for use in a heavy rain storm, or in snowy or icy conditions.

1. Contact with water or excessive moisture can cause an electrical malfunction. The frame, motors, electronics, and other system parts are not water-tight and may rust or corrode if any water gets into the protective covers and shrouds.

To avoid a system failure:

 - Minimize exposure of your system to rain or very wet conditions.
 - **Never** take your system into a shower, tub, pool or sauna.
 - Do not use your system in fresh or salt water (such as at the edge of a stream, lake, or ocean).
 - Make sure all covers and shrouds are secure.
 - Replace joystick boot if it becomes torn or cracked.
 - Make sure all electrical connections are secure.
 - If any of the components does get wet, dry the system as soon as you possible.
2. Proceed slowly and use extra care if you must operate your system on a wet or slick surface.
 - Stop if one or both main wheels lose traction. If this occurs, you may lose control of your system or fall.
 - **Never** operate your system on a slope or ramp if there is snow, ice, water or oil film present.
 - When in doubt, have someone help you.
3. When not in use, keep your system in a clean, dry area.

WARNING

Extra caution should be used when employing the disc switch or the proximity head array as control devices. These two devices are susceptible to malfunction when wet.

K. CENTER OF BALANCE

WARNING

The point where this system will tip forward, back, or to the side depends on its center of balance and stability.

The Center Of Balance Is Affected By:

1. The seat height and seat angle.
2. A change in your body position, posture or weight distribution.
3. Using this system on a ramp or slope.
4. The use of a back pack or other options, and the amount of added weight.
5. Center or rear Drive wheel positioning.

To Reduce The Risk Of A Fall Or Tip-Over:

1. Whenever a condition exists that may change the center of balance, reduce speed, and return the seating system to home position (No tilt, recline, or lift) proceed cautiously.
2. When in doubt, always have someone help you.

L. TRANSFERS

WARNING

It is dangerous to transfer on your own. It requires good balance and agility. Be aware that there is a point during every transfer when the seating system seat is not below you.

To prevent a fall:

1. **Always** turn off power before you transfer to or from your system. If you fail to do so you may touch the joystick and cause your system to move when you do not expect it.
2. Make sure motor brakes are engaged. This keeps the system from moving when you transfer.
3. Work with your health care professional to learn all safe methods for transfers.
 - Learn how to position your body and how to support yourself during a transfer.
 - Have someone help you until you are sure you can do a safe transfer on your own.
4. Move your system as close as you can to the seat you are transferring to. If possible, use a transfer board.
5. Rotate the front casters so that they point forward.
6. Be careful of the footrests. If you can, remove or swing them out of the way.
 - As a standard rule, never stand on footrests when you transfer. Doing so may damage them or cause your system to tip. If the footplate is in contact with the ground, it is possible to use the footplate for a transfer.
 - Make sure your feet do not “hang up” or get caught in the space between the footrests.
7. Make sure armrests are flipped back and do not interfere.
8. Transfer as far back onto the seat surface as you can. This will reduce the risk that you will miss the seat or fall.

Beware Of:

1. Steep slopes. Do Not use this system on a slope steeper than 6%. (A 6% slope means: One foot in elevation for every 16.5 feet of slope length).
2. Wet or slippery surfaces (ice, snow, water or oil film is present) may cause a loss of traction or cause a fall or tip-over.
3. A change in grade on a slope (or a lip, bump or depression). These may cause a fall or tip-over.
4. A drop-off at the bottom of a slope. (A drop-off of as small as 3/4 inch (19 mm) can stop a front caster and cause the system to pitch forward putting the rider at risk).

M. WHEELCHAIR LIFTS

WARNING

Seating system lifts are used in vans, buses, and buildings to help you move from one level to another.

1. **Before** moving onto a lift, return the wheelchair to its home position, (no tilt, recline, or lift).
2. **Always** turn off all power to your system when you are on a lift. If you fail to do so, you may touch the joystick by accident and cause your system to drive off the platform. (Be aware that a “roll-stop” at the end of the platform may not prevent this).
3. Make sure there is not a lip or drop-off at the top or bottom of the platform. These may cause a fall or tip-over. When in doubt, have someone help you.
4. **Always** adjust the position of the user, so that they are securely in the system. This will help prevent falls, or tip-overs while on a lift.
5. **Avoid** moving forward if a wheel is “hung up” on the lip of the ramp. Backup, reposition the caster for a more direct approach. And slowly try again.

N. DRIVING IN LOW-LIGHT OR AT NIGHT

WARNING

The Lighting system on the QM-7 base is designed to aid in visibility while operating the chair in low-light or nighttime driving. It is also intended to make the chair more visible to others. Do not use any lighting system that has been designed by manufacturers other than Sunrise, and that has not been tested or approved for use by Sunrise.

1. Because a lighting system cannot illuminate all obstacles that could endanger the rider, it is important to keep low-light, or nighttime driving to a minimum if possible.
2. Be aware that you are not always visible to driver's or pedestrians when the lights are on, especially if they are viewing you from locations on either side of the chair.

⚠ WARNING

If you use parts or make changes not authorized by Sunrise it may create a safety hazard and will void the Warranty.

A. ARMRESTS**⚠ WARNING**

1. Armrests will not bear the weight of this system.
2. **Never** lift this system by its armrests. They may come loose or break.

B. CUSHIONS**⚠ WARNING**

1. Standard foam cushions and other body supports are not designed for the relief of pressure.
2. If you suffer from pressure sores, or if you are at risk that they will occur, you may need a special seating system or a device that will help control your posture.
 - Consult your Healthcare Professional to find out if you need such a device for your comfort and health.

C. FASTENERS**⚠ WARNING**

Many of the screws, bolts and nuts on this system are special high-strength fasteners. Use of improper fasteners may cause your system to fail.

1. Only use fasteners provided by Sunrise.
2. If fasteners become loose, tighten them immediately.
3. Do not over- or under-tightened fasteners as this can cause damage to your system or it's components.

D. FOOTPLATE & FOOTRESTS**⚠ WARNING**

1. At the lowest point, footrests should be **at least 2 1/2 inches (65 mm)** off the ground. If set too LOW, they may "hang up" on obstacles you can expect to find in normal use. This may cause the system to stop suddenly and tip forward.
2. To avoid a trip or fall when you transfer:
 - Make sure your feet do not "hang up" or get caught in the space between the footrests.
 - Avoid putting weight on the footrests, as the system may tip forward.
 - Remove or swing the footrests out of the way, if possible.
3. The footrest should always be in the down position when operating the system.
4. Never lift this system by the footrests. Footrests detach and will not bear the weight of this system. Lift this system only by non-detachable parts of the main frame.

E. POSITIONING BELTS (Optional)

The positioning belt is predominately used to support your posture. It can also be used to limit slipping and/or sliding that you might experience when the system is in motion. The positioning belt is not a transit rated safety belt and should not be used in the place of a seat belt while being transported in a motor vehicle. Improper use of Positioning belts may cause severe injury or death. If you use a positioning belt, be sure to follow the recommendations in this section:

1. Make sure the rider does not slide down in the seating system seat. If this occurs, the rider may suffer chest compression or suffocate due to pressure from the belts.
2. The belts must be snug, but must not be so tight that they interfere with breathing. You should be able to slide your open hand, flat, between the belt and the rider.
3. A pelvic wedge or a similar device can help keep the rider from sliding down in the seat. Consult with the rider's doctor, nurse or therapist to find out if the rider needs such a device.
4. Use positioning belts only with a rider who can cooperate. Make sure the rider can easily remove the belts in case of emergency.
5. NEVER use positioning belts:
 - a. As a patient restraint. A restraint requires a doctor's order.
 - b. On a rider who is comatose or agitated.
 - c. As a motor vehicle restraint. In an accident or sudden stop the rider may be thrown from the system. Seating system seat belts will not prevent this, and further injury may result from the belts or straps.

If you fail to heed these warnings, damage to your system, a fall, tip-over or loss of control may occur and cause severe injury to the rider or others.

F. PUSH HANDLES**⚠ WARNING**

1. Push handles provide secure points for an attendant to propel and control the system. This helps to prevent a fall or tip-over.
2. Check to make sure push handle grips will not rotate or slip off.

G. SEATING SYSTEMS**⚠ WARNING**

1. Use of a seating system not approved by Sunrise may affect or interfere with other parts of the system.
2. **Never** change the seating system unless you consult your authorized dealer first.
3. Never raise your seating system to a height of more than 22" (measuring from the front of the seat pan to the floor) with all actuators in their home position.

H. UPHOLSTERY FABRIC**⚠ WARNING**

1. Replace worn or torn fabric of the seat sling and/or seat back as soon as you possible. If you fail to do so, the seat may fail and cause you to fall. Worn or torn fabrics may increase the potential for a fire hazard.
2. Fabric will deteriorate with age and use. Look for fraying, thin spots, or stretching of fabric at rivet holes. Replace fabric as required.
3. Be aware that washing may reduce flame retardation qualities of the fabric.

I. WIRING & CONNECTORS**⚠ WARNING**

Never pull on cables directly. This can result in wires breaking inside the connector or harness. To remove a plug or connector, always grasp the plug or connector itself.

J. ASSIGNABLE CONTROLS

WARNING

It is possible to assign a function to an input control (buttons, jacks) to your seating system. If controls have been assigned to perform a dual or alternate function ensure you know what each control operates. Please contact your Authorized Dealer or the Quickie Technical Service Department if you do not receive this information. Failure to do so may result in damage and/or injury.

K. POWER SEATING SAFETY

WARNING

1. Operation

- While driving this seating system in the reclined, elevated, or tilted position use caution.
- Do Not attempt to operate any power seating option while positioned on an incline.
- Do Not attempt to operate any power seating option while this seating system is in motion.
- Do not attempt to operate the lift or tilt power seating options around children.
- Through programming it is possible to reverse the direction of all powered seating functions, ensure you know which direction your seat is going to move before operating.

2. Reduced Speed Driving (Creep)

This power system is designed to automatically reduce the maximum driving speed to a creep mode when certain power seating limits are reached. Depending on the configuration of the chair there might be multiple creep speeds.

3. Pinch points

Pinch points may occur when operating the powered seating options on this system. Ensure all hands and body parts are clear of all power seating components that may result in pinch points before operating them.

4. Tilting Power Base with Push Handles

Do not attempt to tilt power wheelchairs by pulling down on the push handles. Power wheelchairs have heavy bases. As such, attempting to tilt a power seating system to traverse obstacles can damage components in the seating system and/or modular actuators.

5. Remain Clear During Power Accessory Operation

Please stay clear of any powered actuator while the component is in motion. Sunrise power mechanisms move over large ranges of travel. Users should be aware of their surroundings while components are in motion.

6. Maximum User Weight

Do not exceed the weight capacity for your specific system/seating system configuration. Doing so could result in premature failure or injury.

7. Latch Mode

While operating any power seating function in latched mode use caution. In latch mode, powered seating will not stop until a reverse command is performed or the end of travel is met.

L. POWER RECLINE

WARNING

Pinch Point

Avoid putting hands or fingers near the power recline mechanism while in operation.

Weight Capacity

The maximum user weight capacity for the power recline is up to 350 lbs. Exceeding this weight capacity could lead to injury and/or permanent damage to the equipment.

M. POWER LEGREST ACCESSORY

The power legrest accessory has a maximum user weight capacity of up to 300 lbs depending on your system configuration. Never exceed this capacity while operating the powered actuator.

N. LIFT OR LIFT/TILT COMBO

WARNING

Trap Point

Avoid putting hands, fingers, clothing items, or letting children near the seating system when the Tilt/Lift mechanism is in operation.

Weight Capacity

The powered lift and/or lift/tilt modular accessory for this system has a maximum user weight capacity of up to 350 lbs. Never exceed this capacity while operating the powered actuator.

O. SWING-AWAY JOYSTICK ARM

WARNING

Before adjusting the swing-away arm, switch off the controller to avoid accidental displacement of the joystick which would cause unwanted movement of your wheelchair. Be aware that the width of your chair may have increased and you may not be able to go thru certain obstacles.

I. Caution:

- Do not hang any items on or over the parallel swing-away remote assembly as this could damage the swing-away mechanism
- When transferring to and from the wheelchair, do not use the remote as a means of support.
- Only operate the wheelchair at a low and maneuverable speed when the parallel swing-away is in use.

O. TRANSIT 1 2 3 4 5**⚠ WARNING****Important Transit notes for the chair:**

1. If possible and feasible, the rider should transfer to the (OEM) original Equipment Manufacturer vehicle seat and use the vehicle restraint.
2. If the seating system is used for transport, it must be used in a forward-facing seating position during travel in a motor vehicle.
3. The recommended clear zones for wheelchair seated occupants restrained by both pelvic and upper-torso belt(s) and only by a pelvic belt are shown in the diagrams and described below. Frontal Clear Zones (FCZ) need to be larger when upper torso belt(s) are not used. The Rear Clear Zone of 16in is measured from the rearmost point on an occupant's head. The Frontal Clear zone is measured from the front most point of an occupant's head and is 26-inches with pelvic and upper-torso belt(s) and 37 inches with only a pelvic belt. The frontal clear zone may not be achievable for wheelchair- seated drivers.
4. The estimated seated height (HHT) from the ground or floor to the top of the wheelchair-seated occupant's head ranges from approximately 47 inches for a small adult female to about 61 inches for a tall adult male.
5. The rider must not weigh more than 350 lbs.
6. Attach WTORS to securement points in accordance with the manufacturer's instructions and SAE J2249.
7. Ensure hip guides are mounted and are locked in place.
8. Use only Wheelchair Tie-down and Occupant Restraint Systems (WTORS) which meet the requirements of SAE J2249 Recommended Practice- Wheelchair Tie-down and Occupant Restraint Systems For Use in Motor Vehicles. Do not use WTORS designed to rely on the wheelchair structure to transfer occupant restraint loads to the vehicle.
9. In order to reduce the potential of injury to vehicle occupants, wheelchair-mounted accessories, such as trays and respiratory equipment, should be removed from the seating and wheelchair and secured separately.
10. Postural supports and positioning devices should not be relied on for occupant restraint.
11. Do not alter or substitute wheelchair frame parts, components or seating.
12. Sudden stops or impacts can structurally damage your system. Chairs involved in such incidents should be replaced.

Important Transit notes for Occupant restraints:

13. Attach occupant restraints in accordance with the manufacturer's instructions and SAE J2249.
14. Both pelvic and upper torso restraint belts must be used to restrain the occupant to reduce the possibility of head and chest impacts with the vehicle components and serious risk of injury to the user and other vehicle occupants.
15. The upper torso restraint belt should be mounted to the vehicle (B) pillar - failure to do so will increase the risk of serious abdominal injuries to the user.
16. A head restraint suitable for transportation must be fitted and suitably positioned at all times during transportation.
17. The pelvic restraint belt (C) must be worn low across the front of the pelvis so that the angle of the pelvic belt is within the preferred zone of 30 to 75 degrees to the horizontal.
18. A steeper (greater) angle within the preferred zone is desirable, closer to, but not exceeding 75 degrees.
19. The upper torso restraint belt (A) must fit over the shoulder and across the chest.
20. Restraint belts must be adjusted as tightly as possible consistent with user comfort, and should not constrict breathing.

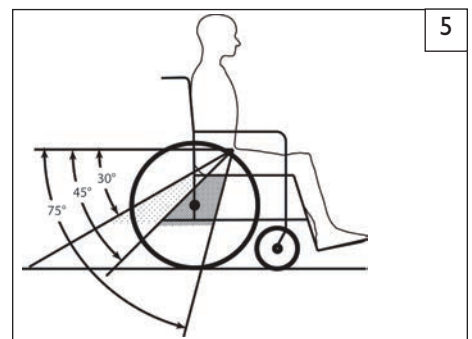
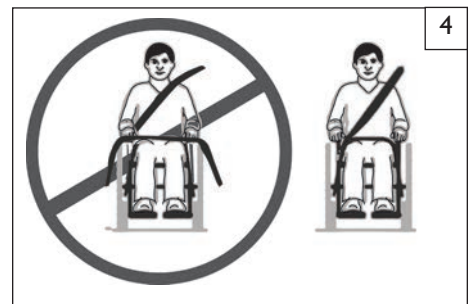
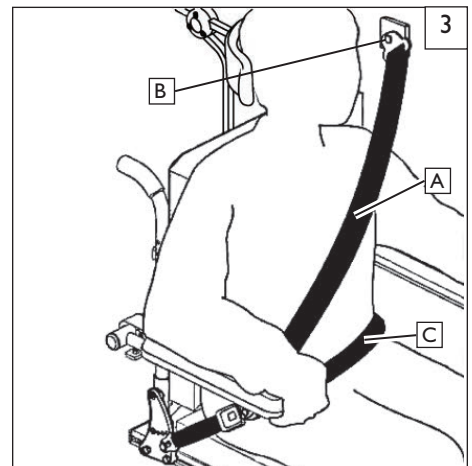
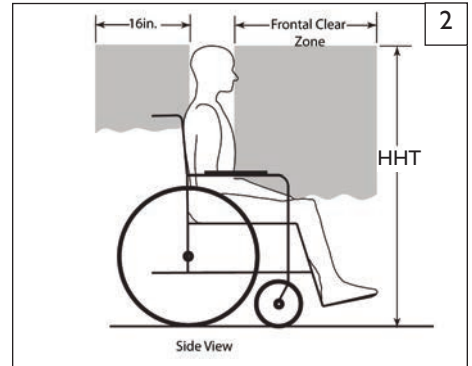
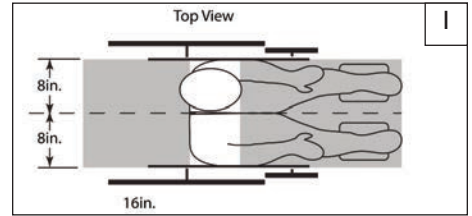

⚠ WARNING

The owner and/or Caregiver using this product, is responsible for making sure that it has been setup and adjusted by an Authorized Dealer under the advice of a healthcare professional. The system may require periodic maintenance or certain in-use adjustments that may be performed by the owner or caregiver.

A. INTRODUCTION

⚠ WARNING

1. Your system needs regular maintenance for peak performance and to avoid injury from system failure, damage or premature wear.
2. Inspect and maintain this system per the “Safety Checklist”.
3. If you detect a problem, make sure to service or repair the system before use.
4. At least once a year, have a complete safety check and service of your system performed by a Authorized Dealer.

B. CLEANING

1. Paint Finish:

- Clean the paint finish with mild soapy water monthly.
- Protect the paint with a coat of non-abrasive auto wax every three months.

NOTE– You do not need to grease or oil the system.

2. Upholstery:

- Hand-wash only as needed. Machine washing may damage fabric. Allow upholstery to dry at least 24 hours before use.
- Drip-dry only. Heat from a dryer may damage fabric.

NOTE– Washing the fabric may decrease fire retardant properties.

3. Joystick:

- Use a cloth that has been slightly dampened with diluted detergent. to clean the joystick and boot.
- LCD Screen can be cleaned with a soft, lint free, dry cloth.

NOTE - When cleaning the Joystick and screen, NEVER use any type of window cleaner, scouring powder, or any cleanser with solvents such as alcohol, benzene, ammonia, or paint thinner. Never use abrasive pads or paper towels.

C. STORAGE TIPS

1. Store your system in a clean, dry area, that is protected from sunlight. If you fail to do so, parts may rust or corrode.
2. Before using your system, make sure it is in proper working order. Inspect and service all items on the “Safety Checklist”
3. If you store this system for more than three months, have it inspected by an Authorized Dealer before use.

D. ORDERING PARTS

When you order parts, provide the following:

1. Model of system
2. Serial number of system
3. Left hand or right hand control
4. Part number, description and quantity of parts you need.
5. State reason for replacement.

E. SAFETY CHECKLIST

You should check the items on this chart at the indicated intervals. If any of the items are loose, worn, bent or distorted, immediately have them checked and/or repaired by your Authorized Dealer. Frequent maintenance and servicing will improve performance, extend wheelchair life, and help prevent injuries.

SAFETY & FUNCTION CHECK	Daily	Weekly	Monthly	Quarterly	Annually
Check Joystick (no damage)	<input checked="" type="checkbox"/>				
Seat interface (attached and tight)	<input checked="" type="checkbox"/>				
Cushions and padding (in place)	<input checked="" type="checkbox"/>				
Check plugs and connectors for proper connections	<input checked="" type="checkbox"/>	<input checked="" type="checkbox"/>	<input checked="" type="checkbox"/>		
Check all moving parts for wear				<input checked="" type="checkbox"/>	
Inspect all nuts, bolts and fasteners for looseness or wear				<input checked="" type="checkbox"/>	
Inspect upholstery for wear				<input checked="" type="checkbox"/>	
Service by authorized dealer					<input checked="" type="checkbox"/>

F. FLIP-BACK CANTILEVER ARMRESTS 7

The armrests(A) on both sides of the wheelchair can be flipped back to allow a side transfer from either side of your seating system.

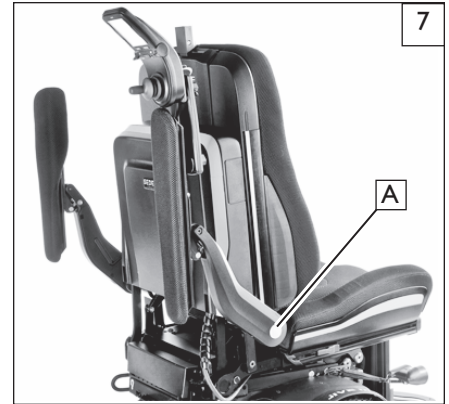
**G. LIFT OFF BOLSTER PAD** 8

To facilitate side transfers, you can swing-out and remove the side support cushion(B) without the use of tools.

1. Removing the bolster pad:

- Pull the plastic lever(C) that is attached to the aluminum seat side rail backwards.
- Swing the back part of the cushion outwards to an angle of approximately 10°.
- Lift the cushion out from the front pin.

2. Refitting the bolster pad:

- Be careful of pinchpoints with this task, Align the pin at the front edge of the seat plate with the hole of the aluminum side rail.
- Slide the rail onto the pin and swing the side cushion all the way in, until the latch locks with an audible click.

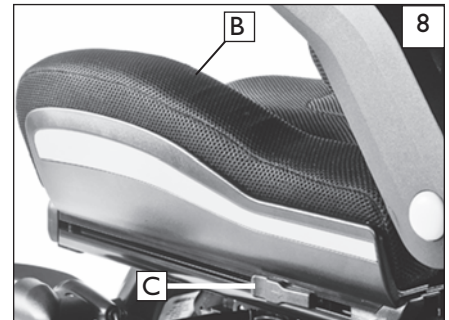
**H. SWING-AWAY, LENGTH ADJUST AND MIDLINE****JOYSTICK MOUNTS** 9 10

The joystick is mounted with a mechanism that allows the joystick to be locked in a forward or retracted position, and can accommodate a midline mount so the joystick can be located in the center of the chair.

Swing-away

- To Swing-away the joystick, push outward on the inside of joystick.
- Push the joystick away from the front of the armrest until it locks into the swing-away position.
- To return to forward position, push the joystick mount (D) forward until it locks into place.

Rotating the Midline Mount.

- Push in on the release button (E) at the end of the joystick arm.
- The Joystick and midline arm should rotate out of the way.
- To return to midline position, repeat step(a) and rotate the joystick mount back to its original position until it locks into place.

Length adjustment

- Loosen the locking handle(F)
- Slide the control arm either out or in to its new position.
- When the most comfortable position has been selected, secure the slider by tightening the locking screw. Ensure that the locking screw is fully tightened before use.

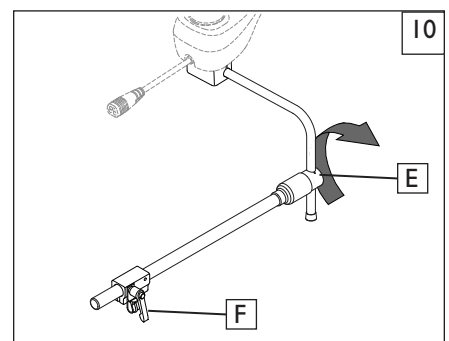
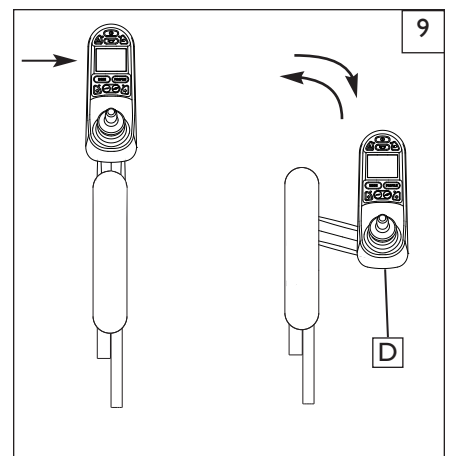

I. HEADREST HEIGHT AND DEPTH ADJUSTMENT 11 12

Once the headrest has been mounted, there is an option of an easy height adjustment.

1. Adjusting the headrest height

- a. Loosen securement knob (A).
- b. Press the spring loaded locking lever (B).
- c. Raise or lower the headrest support (C) to the desired height and release the lever.
- d. Double check that the locking lever is engaged and the headrest is locked in place.
- e. Tighten securement knob (A).

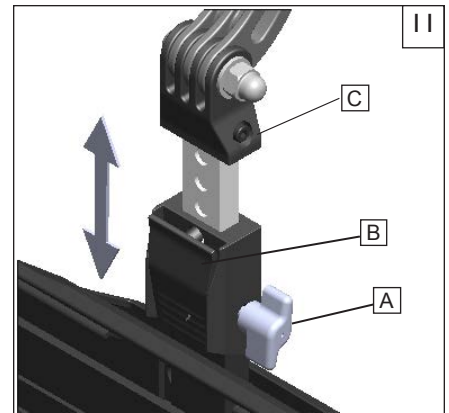

2. Adjusting the headrest height and depth with Quick-release handles.

- a. Loosen the quick-release handles (C).
- b. Articulate the headrest (D) to the desired height and depth and tighten the handles.
- c. Make sure the headrest is locked in place by double-checking that the adjust handles are tight.

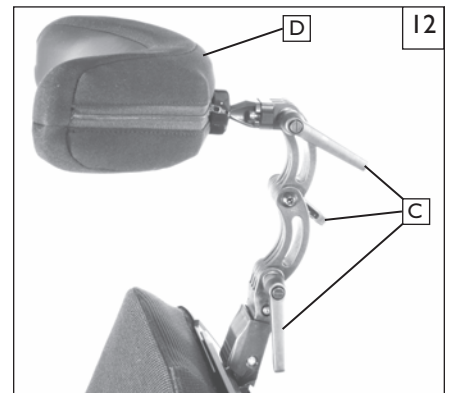

J. CHECK-OUT

Once the seating system is assembled and adjusted, it should work smoothly and easily. All accessories should be checked to make sure they are also performing smoothly. Be sure that the system performs to your specified operational settings.

If the system does not perform the way you expect it to, (according to specifications), turn your wheelchair OFF immediately and contact your authorized supplier to re-program operational settings using the RNET operating guide.

If you have any problems, follow this Procedure:

- a. Review the Set-up, Adjustment, and use section and the Operating Guide to make sure the system was properly prepared.
- b. If your problem persists, contact your authorized supplier. If you still have a problem after contacting your authorized supplier, contact Sunrise Medical Customer service. See the introduction page for details of how to contact the people who can help you.

A. CONTROLS 13

Omni Input Display

The Omni is a universal specialty controls interface that accepts signals from many different types of SIDs and translates them into commands compatible with the PG Drives Technology RNET control system.

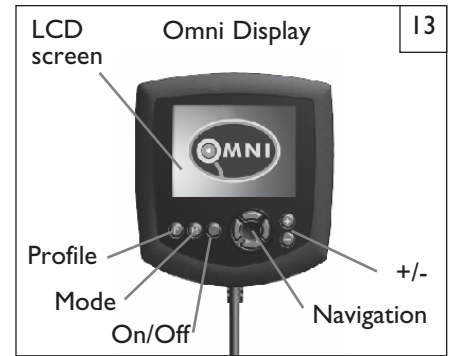

B. CONNECTORS 14 15

Mating Connectors

To connect the communication cables (A):

Holding the connector housing, firmly push the connector into its mate until you can no longer see the yellow plastic. The connectors are secured using a friction system.

To disconnect the communication cables:

Holding the connector housing firmly, pull the connectors apart.

NOTE– Do not hold or pull on the cable. Always grip the connector when connecting and disconnecting.

When the control system is first switched on after a connection, or system component change, the timer will be displayed while the system checks itself. Then the re-start icon will be displayed. Switch the control system off and on again to operate,

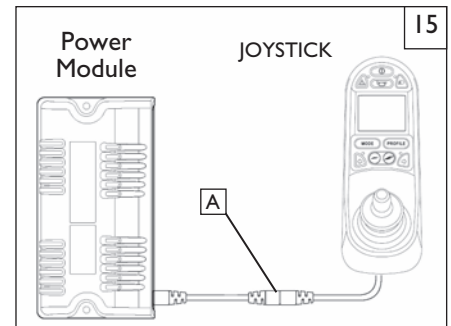
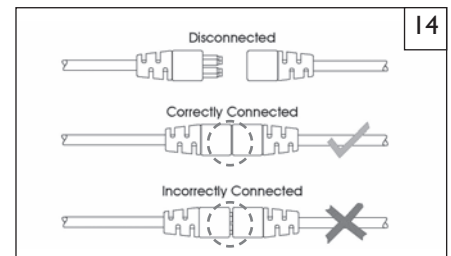

C. R-NET JOYSTICKS 16



Controls: Color Display, and Advanced Joystick

Joystick key: LCD Screen (B), Paddle Switch (Left and Right) (C), External Profile Jack (D), External On/Off Switch Jack (E).

WARNING

Cleaning the LCD screen (B)

1. **ALWAYS** use a soft, clean, lint free, dry cloth
2. To clean fingerprints and greasy smudges off of your LCD screen use a screen cleaning solution that is designed for LCD screens (Non-ammonia based). Put a small amount of the solution on a clean, lint free, dry cloth and rub the screen gently.
3. **NEVER** use any type of windex cleaner, soap, scouring powder, or any cleanser with solvents such as alcohol, benzene, ammonia, or paint thinner.
4. **NEVER** use abrasive pads or paper towels. If you do, you can scratch the screen or strip the anti-glare coating off of the screen and cause permanent damage to the Joystick screen.

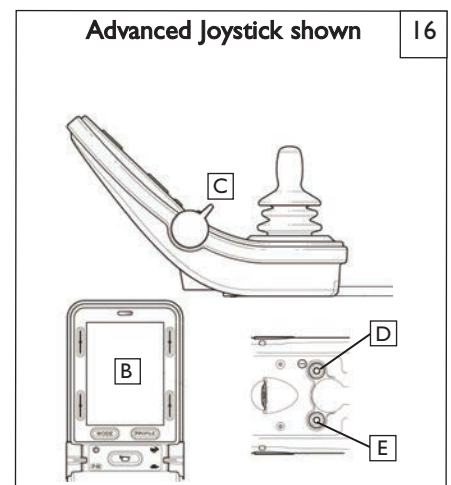

D. JOYSTICK BUTTONS AND CONTROLS (Color) 17 18 19

On/Off Button A

The on/off button applies power to the control system electronics, which in turn supply power to the wheelchair's motors. Do not use the on/off button to stop the wheelchair.

Horn Button B

The horn will sound while this button is depressed.

Emergency Flasher On/Off C

Lights will flash when this button is depressed.

Lights On/Off D

The lights will illuminate this button is depressed.

Mode Button E

The Mode button allows the user to navigate through the available operating modes for the control system. The available modes are dependent on programming and the range of auxiliary output devices connected to the control system.

Profile Button F

The Profile button allows the user to navigate through the available operating profiles for the control system. The available profiles are dependent on programming and the range of auxiliary output devices connected to the control system.

Speed Increase / Decrease Button G

These buttons Increase or decrease the maximum speed setting. If the control system is programmed for drive profile operation, the buttons select a lower or higher drive profile.

Menu Navigation H

This LED set displays which actuator channel is currently being controlled when the control system is in Actuator Mode. Actuator selection and operation is achieved using the joystick.

- Motions to the LEFT or RIGHT select different actuator channels.
- Motions FORWARD and BACKWARD move the actuator(s) selected.

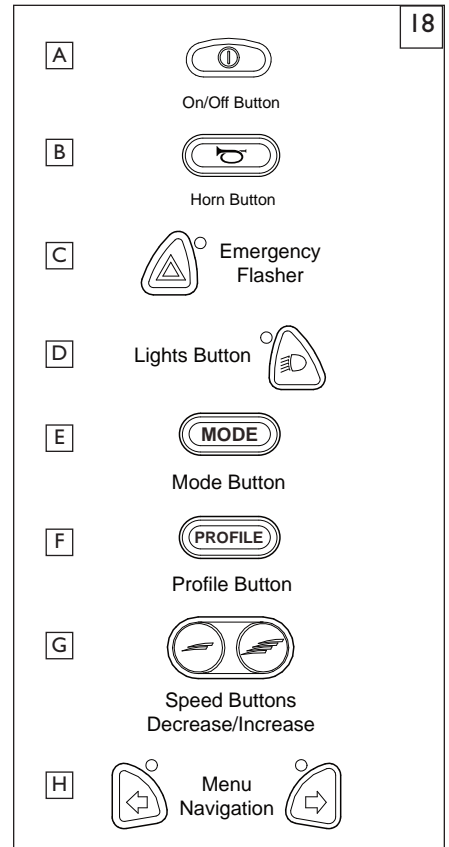
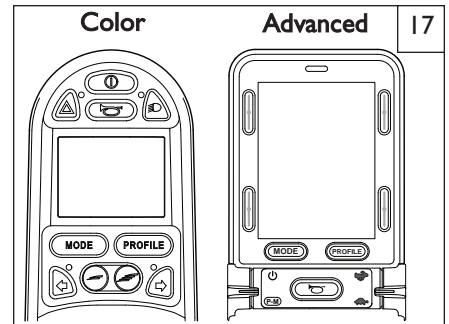

E. JOYSTICK BUTTONS AND CONTROLS (Advanced)

Screen Side buttons I

These buttons operate lighting functions: Hazards, lights, left and right indicator. Once the function is activated, the icon will appear on the screen.

- If no lighting system is fitted, the buttons will be inactive.
- In all instances, the top left button, when held for a short time, will open the settings menu.

Left Paddle switch J

Power On/Off, (Do not use this to stop the wheelchair)

Profile/Mode: Allows the user to navigate thru the available drive profiles and modes.

Right Paddle switch K

This button increases or decreases the maximum speed setting. A momentary screen may be displayed when the paddle is operated. Depending on the programming, the paddle switch can act as a momentary speed control, or as a continuous speed control.

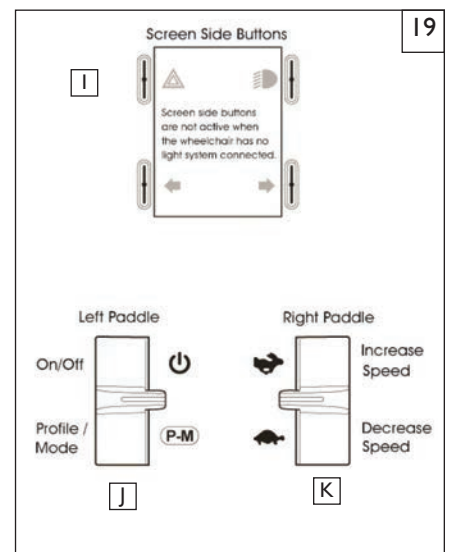

E. LCD SCREEN (color and advanced) 20

This section covers those joystick modules that are fitted with a color LCD screen. The color LCD screen is split into three areas of information. The Top Bar(A), the Text Bar(B) and the Main Screen Area(C).

1. TOP BAR (A) 21**Battery Indicator:**

Displays the charge available in the battery and alerts the user when the charge level is low.

- Steady: Indicates that all is well.
- Flashing Slowly: The control system is functioning correctly, but you should charge the battery as soon as possible.
- Stepping Up: The wheelchair batteries are being charged. You will not be able to drive the wheelchair until the charger is disconnected and you have switched the control system off and on again.
- If the battery gauge shows red, yellow and green, the batteries are charged (bars 1-10).
- If the battery gauge shows just red and yellow, then you should charge the batteries as soon as you can (bars 1-7).
- If the battery gauge shows just red, then you should charge the batteries immediately (bars 1-3).

2. MAIN DRIVE SCREEN (B) (color and advanced)**Profile Name** 22

A text string that displays the name of the currently selected profile.

Clock 23

Displays the current time in a numeric format.

Color Joystick Speed Display 24

Gives a proportional display of the wheelchair's speed.

Maximum Speed Indicator 25

Displays the current maximum speed setting.

Digital Speed Display 26

Displays the actual speed of the wheelchair derived from the motors.

Advanced Joystick Speed Display 27

Gives a proportional display of the wheelchair's speed.

Odometer 28

Displays the distance driven by the wheelchair. The display can show either the total distance or the trip distance, in miles or kilometers. The Settings Menu contains an option that sets whether the trip or total distance is displayed, as well as a facility to reset the trip distance. If Latched operation is active, then that symbol will take priority over the odometer.

Advanced Joystick Max speed indicator 29

Displays the current maximum speed setting.

3. TEXT BAR (C) (color Joystick)**Current Profile** 20

The currently selected profile is shown in numeric form or may be displayed as text. Temperature warnings may also be displayed on this bar.

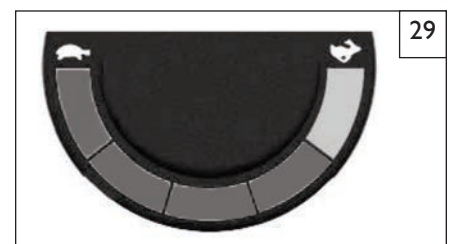
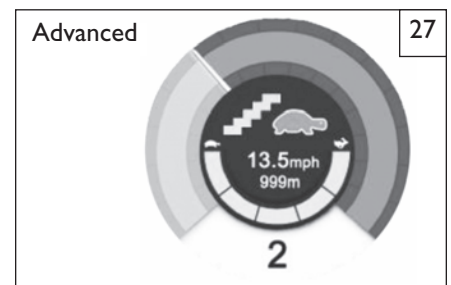
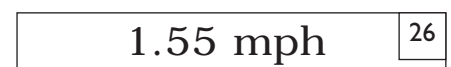
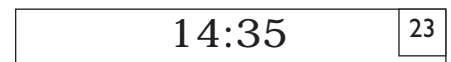

4. IMPORTANT ICONS AND MESSAGES (color and advanced)

Latched ³⁰

When the control system is operating in a Latched condition this symbol will be displayed.

Inhibit ³¹

If the speed of the wheelchair is being limited; for example, by a tilted seat, then this orange symbol will be displayed. If the wheelchair is being inhibited from driving, then this red symbol will be flashing.

5. MODE SCREENS:

Actuator (Seating) Mode ³²

Displays the sections of the system currently selected for movement, the name given to the selection and a direction arrow showing what sort of movement is available.

Speed Adjust ³³

When Speed Adjust Mode is entered, this screen will be displayed momentarily.

Color Joystick Message Window ³⁴

The RNET displays warning icons and informational messages, in a dedicated message window.

Advanced Joystick Message Window ³⁵

The RNET displays warning icons and informational messages, in a dedicated message window.

Restart ³⁶

When the control system requires a reboot; for example, after a module re-configuration, this green symbol will be flashed.

E-Stop ³⁷

If the External Profile Switch is activated during drive, or actuator operation, this red symbol will be displayed.

Joystick Displaced ³⁸

If you operate the Joystick before or just after you switch the control system on, the screen will flash the joystick displaced screen.

You must release and center the joystick to resume normal operation. If you do not release the joystick within five seconds the wheelchair will not be able to move, even if you release the joystick and operate it again. The screen will display a diagnostic screen at this time. You can reset this condition by switching the control system off and on again.

Control System Locked ³⁹

The control system can be locked in one of two ways. Either using a sequence of deflections and presses with the Joystick, or with a physical key. How the control system is locked depends on how the wheelchair manufacturer has programmed it. Refer to the R-Net technical manual SK77981- Programming chapter for more details.

6. MOMENTARY SCREENS ⁴⁰

If the momentary screens are programmed to be displayed, then pressing the Speed or Profile Buttons will display screens such as this.

7. DIAGNOSTIC SCREEN ⁴¹

When the control system safety circuits have operated and the control system has been prevented from moving the wheelchair, a diagnostics screen will be displayed. This indicates a system trip, i.e. the RNET has detected a problem somewhere in the wheelchair's electrical system.

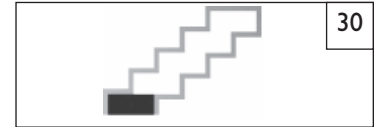

30

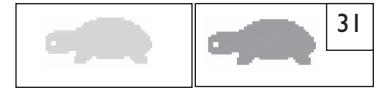

31



32

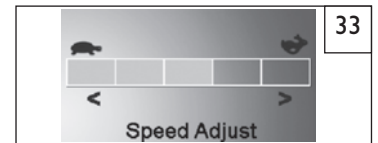

33



34



35



36

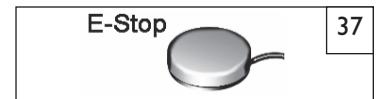

37



38



39



40

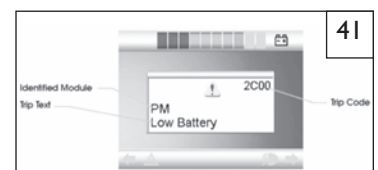

41

G. JOYSTICK STATIONARY

Your system has an available programming feature called “Joystick Stationary” which can be set by your dealer. This feature senses when the joystick is displaced from neutral, yet left in a steady position for a predetermined period of time. The controller will automatically turn off if the set time has been reached. This feature is designed to protect the user, batteries and electronics if the joystick is inadvertently displaced. There are two parameters that can be adjusted:

1. Joystick Stationary Time:

This is the time the joystick has to remain within the stationary range before the unit will come to a stop. It can be programmed from 0 to 60 minutes in steps of one minute. Select 0 to disable the function. Default setting may depend on motor package.

2. Joystick Stationary Range:

This determines the size of a region around the present joystick position. If the joystick remains within this region for the stationary time the controller will stop. The range can be programmed from 1 to 50, in steps of 1. Default setting is 10.

WARNING

Before adjusting these parameters, carefully read and understand the implications for use of these features, Joystick Stationary Time and Joystick Stationary Range. When the “Joystick Stationary Time” is reached within the “Joystick Stationary Range”, the drive motors on the system will shut off. As an example, this will happen while driving in a straight line for extended periods of time with no joystick movement. Once the drive motors turn off, the user will need to turn the system off and back on to drive.

H. THERMAL ROLL-BACK

Your system has a thermal roll back circuit. This protects the controller from damage due to overheating. In extreme conditions (such as repetitive hill climbing) the circuit will decrease the power to your motors. This allows the system to operate at a reduced speed. When the controller cools, the system will return to normal speed.

I. POWER RECLINE, TILT & LIFT OPERATION

The power recline, tilt and lift features on your system can all be operated using the joystick on your system. Follow the instructions below to operate:

If the thru drive option was selected,

1. Make sure your controller is on.
2. From the Drive Mode, press the Mode button to enter Power Seating Mode.
3. Move the joystick left or right selecting the power option (recline, tilt, lift, legrests) you wish to control.
4. Move the joystick forward or backward to adjust the selected power option to the desired position.
5. Press the Mode button to return to normal operation or continue moving the joystick left or right to adjust the next power option. Multiple Mode button presses will be necessary if other modules, such as Bluetooth or Output, are active.

J. SETTING SEAT MEMORY POSITION

The Sedeo Ergo has 5 pre-defined seat memory positions. Each memory location has a set of factory seat positioning presets: Seating, Stand-up, Lie-down, transfer, and relax. Although there is one free programmable seat memory position, all predefined memory positions, if not suitable for the user, can be changed and customized to the needs required. Seating memory positions should only be changed by an Authorized supplier.

1. Saving a new position in memory

- a. Remove the rear cover of the backrest and connect a switch with a 3.5mm jack to the socket connected to I6 on the CSxM.
- b. Press the “Mode” button one or more times until a seat icon appears in the LCD control panel display.
- c. Move the Joystick left or right to select a memory seat position. A seat icon and the memory description for the relevant position are shown in the LCD control panel display.
- d. Adjust the seating system to the position you would want to save into the memory.
- e. Press and hold the switch connected to the CSxM and pull the joystick backwards for 3 seconds until a beep is heard.
- f. release the Joystick and the button. Your new position is now stored in memory.
- g. It is possible using a dongle or PC to name and save the seating position in the memory.

2. Return to drive mode.

- a. Press the “Mode” button one or more times until a standard display image with speed indicator appears in the LCD control panel display.

3. Retrieving memory position.

- a. Press the “Mode” button one or more times until a seat icon appears in the LCD control panel display.
- b. Move the joystick to the left or right to select a memory seat position.
- c. Move and hold the joystick forwards. The seat adjusts to the factory preset position.
- d. The movement can be stopped at any time by letting go of the joystick. It can be started again by pushing the joystick forwards.
- e. During a stop period, another memory position may be selected with a right or left movement of the Joystick.

4. Delete custom memory positions.

- a. Remove the rear cover of the backrest and connect a switch with a 3.5mm jack to the socket connected to I6 on the CSxM.
- b. Press the “Mode” button one or more times until a seat icon appears in the LCD control panel display.
- c. Move the joystick to the left or right to select a memory seat position. A seat icon and the memory description for the relevant position are shown in the LCD control panel display.
- d. Press and hold the switch connected to the CSxM and pull the joystick backwards for 6 seconds. After 3 seconds, you will hear the programming beep, and after 6 seconds you will hear a change in the beep sound.
- e. As soon as you hear this new sound, release the joystick and the button. All memory positions are now set to the factory default settings.

K. PRESSURE RELIEF ALERT AND RECORDING

The Sedeo Ergo Pressure Relief Alert and Recording feature (PRAR) provides programmable alerts that will prompt the user when it is time to perform pressure relief repositioning.

1. **Alert interval can be set at 15 min, 30 min, 60 min, 120min, 240min, or off using the PC programmer.**
2. **Duration (time spent in pressure relief position can be set from 1-15 minutes in increments of 1 minute.**
3. **Pressure Relief reminder counters can be viewed using the PC programmer CxSM application windows.**
4. **Resetting Pressure Relief Alert counters:**
 - a. Remove the rear cover of the backrest and connect a switch with a 3.5mm jack to the socket connected to I8 on the CSxM.
 - b. Press the "Mode" button one or more times until a seat icon appears in the LCD control panel display.
 - c. Move the joystick to the left or right to select a memory seat position. The seat icon and the memory description for the relevant position are shown in the LCD control panel display.
 - d. Press and hold the switch connected to the CSxM and press the joystick forwards for 3 seconds. Until a beep is heard.
 - e. As soon as you hear this beep, release the joystick and the button. All pressure relief reminder counters are now reset to zero.

L. SELECTED SOUND MUTE

The Sedeo Ergo uses sound tones to alert the user to respond to pressure relief reminder alerts and to alert the user to errors in the seating system. These sound tones can be muted if desired.

1. **Mute selected sounds:**
 - a. Remove the rear cover of the backrest and connect a switch with a 3.5mm jack to the socket connected to I8 on the CSxM.
 - b. Press and hold the switch connected to the CxSM for 3 seconds until a beep is heard.
 - c. Release the button. Selected sounds are muted.
2. **Un-Mute selected sounds:**
 - a. Remove the rear cover of the backrest and connect a switch with a 3.5mm jack to the socket connected to I8 on the CSxM.
 - b. Press and hold the switch connected to the CxSM for 6 seconds. After 3 seconds there will be a mute beep, and after 6 seconds there will be a change in the beep sound.
 - c. As soon as the new beep sound is heard, release the button. Selected sounds will now be the preferred notification sounds.

WARNING

The owner of this system is responsible for making sure that it has been setup and adjusted by a trained service professional under the advice of a Healthcare Professional. Service or adjustments should only be done with the advice of a Healthcare Professional. Always use parts and accessories that have been recommended and approved by Sunrise Medical when servicing this system.

A. DEALER SERVICE INTRODUCTION

1. At least once per year, this system should have a complete inspection, safety check, and regular service made by an authorized dealer.
2. If you have discovered a worn, bent, or damaged part, repair or replace them with recommended parts **before returning this system to service.**
3. All major maintenance and repair work should be done by the Authorized Dealer.
4. The tool list at right is essential for any significant repair or maintenance work.

B. CRITICAL MAINTENANCE TIPS

1. Torque settings:

A torque setting is the optimum tightening which should be made on a particular fastener. It is important to use proper torque settings where specified. When not specified, torque settings should be set at a minimum of 60 in-lbs.

2. Dealer Service and Adjustment Reference materials:

Go to www.sunrisemedical.com for parts manuals, instruction sheets, and instructional videos that will aid in the repair of the Quickie Family of wheelchairs.

C. CLEANING

1. Paint Finish

- a. Clean the painted surfaces with mild soap or detergent.
- b. Protect the paint with a coat of non-abrasive auto wax.

2. Axles and Moving Parts

- a. Clean around axles and moving parts with a slightly damp (not wet) cloth.
- b. Wipe off or blow away any fluff, dust or dirt on axles or moving parts.
- c. **DO NOT USE 3 in 1 oil, or WD-40 ® for lubrication.** Only use Teflon based Lubricant when working on this wheelchair.

D. ADJUSTMENT NOTES

1. Work Surface For Set-Up:

Use a flat surface, such as a table, to assemble, adjust and check your system. This makes the steps easier and helps ensure a correct set-up.

2. Fasteners:

- Many of the screws and bolts on this system are special high-strength fasteners and may have special coatings.
- Many nuts are of the Nylock type. They have a plastic insert to help prevent loosening.
- Only use screws, bolts and nuts provided by Sunrise.

WARNING

1. Use of improper fasteners may cause the system to fail.
 2. Over- or under-tightened fasteners may fail or cause damage to system parts.
 3. If bolts or screws become loose, tighten them as soon as you can. Loose bolts or screws can cause damage to other system parts causing them to fail.
3. Washers & Spacers:
- Note the position of washers and spacers before disassembly.
 - To avoid damage to the frame, replace all washers and spacers when you reassemble parts.

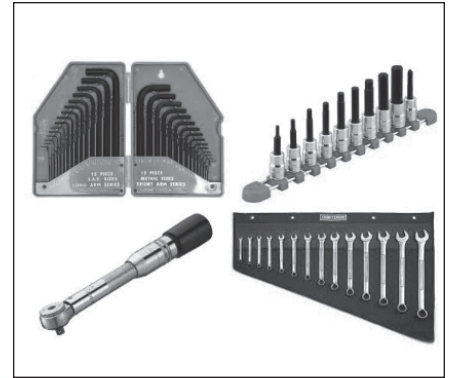

TOOLS YOU WILL NEED

1. Imperial Hex key set
2. Metric Hex key set
3. Imperial Open-end Wrench set
4. Metric Open-end Wrench set
5. Torque wrench
6. Imperial Hex bit Socket set
7. Metric Hex bit Socket set
8. Phillips and Flat screwdrivers

E. FLIP-BACK ARMRESTS 1**1. Adjusting the Armrest width**

- a. Using a 5mm hex key remove the 2 locking screws (A) on the traversing tube at the rear of the chair.
- b. Move both the right and left armrest receiver brackets to the desired position.
- c. Check the total width of the chair from side to side to make sure that the new adjustment does not interfere with daily obstacles (like doorways) and seating position.
- d. Insert and hand thread the screws.
- e. Tighten the hardware when adjustment is complete.

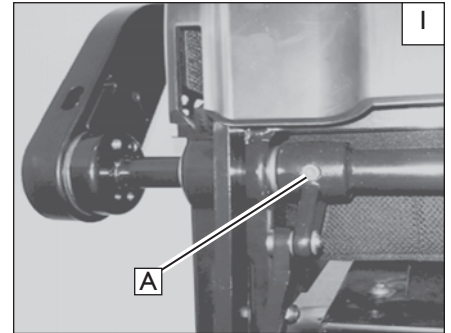
**2. Adjusting Armrest Height** 2

NOTE– Do not exceed a torque of 10nm when adjusting the screw(B).

- a. Using the 5mm hex key stored on the inside of the lefthand armrest, turn the height adjustment screw(B) to move the armrest either up or down depending on the rotation direction of the height adjustment screw.
- b. Adjust the angle of the armrest and joystick after finishing with the height adjustment.
- c. Repeat this process on the opposite Armrest

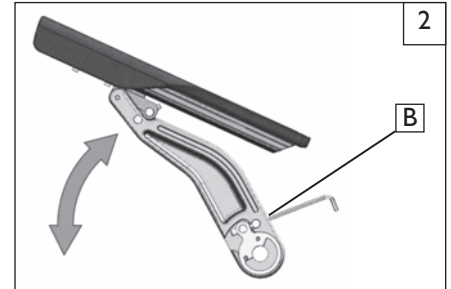
**3. Angle adjustment and/or leveling the armrest after height adjustment.** 3

NOTE– Do not exceed a torque of 10nm when adjusting the screw (C).

- a. Locate the angle adjustment screw (C) at the bottom of the armrest and adjust the angle by using a 5mm hex key and rotating the screw until either the armrest is either level or at the appropriate angle for the user.
- b. Do not loosen the screw to the point where it will fall out of the armrest. If this happens simply re-thread the screw into the armrest until it starts to angle adjust the armrest again.
- c. Repeat this process on the opposite Armrest

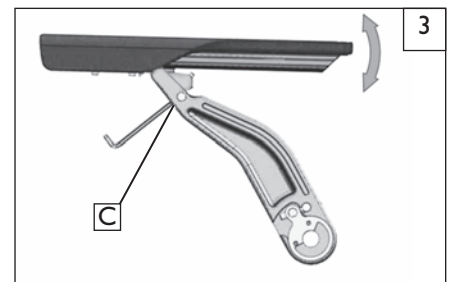
**4. Adjusting the Armpad forward or backward** 4

- a. Locate the armrest adjustment screws (D)(E) at the bottom of the cantilever arm and using the 5mm hex key loosen the screws.
- b. Move the armpad forward or backward to desired adjustment.
- c. Repeat this process on the opposite Armrest and tighten the screws.

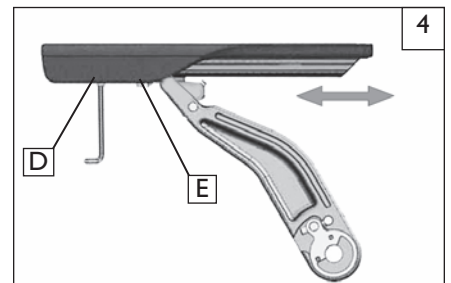
**5. Adjusting the Armpad angle inward or outward.** 5

- a. Locate the armpad adjustment screw (D) and remove it.
- b. Loosen screw (E).
- b. Move the screw (D) and T-nut (not shown) from the front hole to the slot hole(F).
- c. Set the angle and then tighten the hardware.

NOTE - All screws should be checked periodically for tightness. A loose arm pad could slip down when pressed.

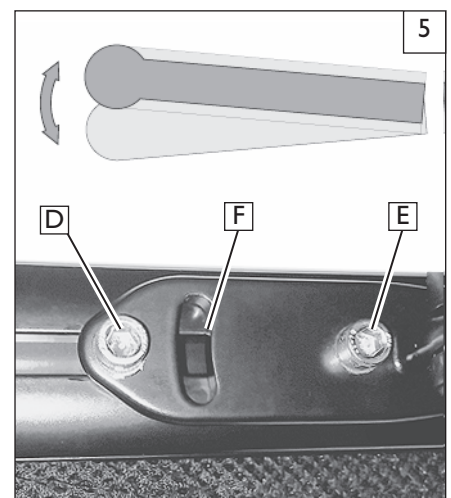

F. ADJUSTING THE SEAT PLATE WIDTH 6

When cushion widths vary, you can compensate with a seat plate adjustment. Before adjusting to a larger width for the seat plate, be sure to adjust the armrest width first. (Section E Flip-back armrests)

I. Adjusting the Seat plate width

- Remove the seat cushion.
- Using a 5mm hex key, loosen the four screws(A)(B) on the seat pan.
- Slide the plates outwards or inwards, and align the seat width with the desired value shown on the scales visible thru the windows in the seat pan(C).
- The seat width is indicated by the scale that runs alongside each slot
- Tighten the hardware when adjustment is complete.

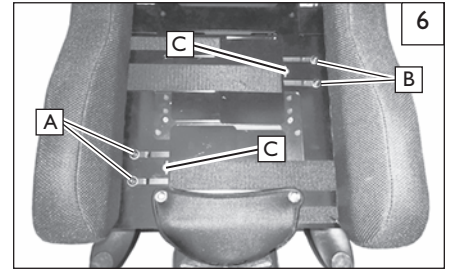

G. ADJUSTING THE BACK PLATE WIDTH 7

When Back pad widths vary, you can compensate with a back plate adjustment.

I. Adjusting the Back plate width

- Remove the back pad.
- Using a 5mm hex key, loosen all 12 screws on the back plate.
- Slide the plates outwards or inwards to achieve the required back width.
- The back width is indicated by the scales(D) on the backplate.
- Scale(E) needs to align the correct back width with the pin to center the back after the adjustment is made.
- Tighten the hardware when adjustment is complete.

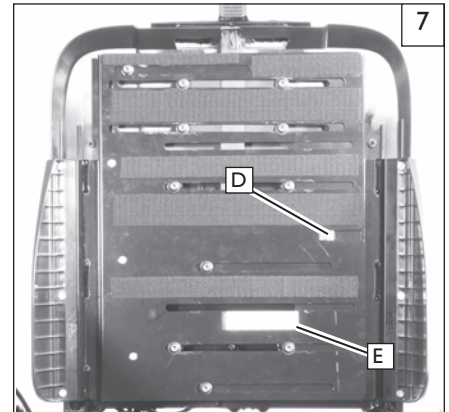

H. ADJUSTING SEAT DEPTH 8 9

⚠ WARNING

Adjusting the seat depth on the Sedeo Ergo can alter the center of gravity of the unit. This adjustment could cause interference with the basic functions like tilt and recline ranges. It is strongly recommended that an authorized supplier makes this adjustment. In most cases it will also be a requirement to ensure that the length of any cables is appropriate for the new seat depth, and that the seat pan be shifted to maintain the proper center of gravity.

I. Adjusting the Seat depth

- Using a 5mm hex key, loosen the 2 screws(F) on the bottom of the outer seat plate, but do not take them completely out, they are meant to hold the shift pieces.
- The back assembly can now be shifted backwards or forwards using the seat adjustment scale(G) to adjust the seat depth.
- Tighten the hardware when adjustment is complete.

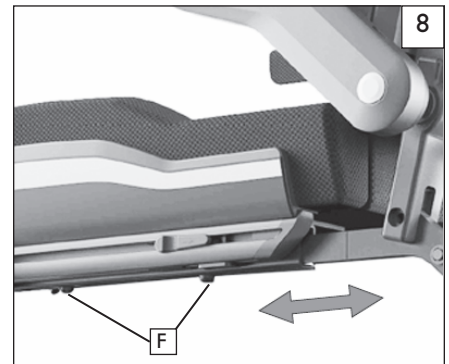

IMPORTANT NOTE - Please contact Sunrise Medical Technical Support when adjusting the seat depth across the values listed below.

***Seat depths that require a shift in programming**

Ultra-Low STFH STFH Seat Frame "A"	Std Tilt Equipped	16.5" STFH	16"-17", 18"-19", 19"-20" *20"-21"
		All other STFH	16"-17", 19"-20" *20"-21"
	HD Tilt Equipped	All STFH	16"-17", 19"-20" *20"-21"
	Tilt-Lift Equipped	All STFH	*16"-17" 18"-19", 20"-21"
Standard STFH Seat Frame "B"	Std Tilt Equipped	17" STFH	16"-17", Do not go beyond 18" max seat depth
		17.5" STFH	16"-17", Do not go beyond 19" max seat depth
		All other STFH	16"-17", 19"-20" *20"-21"
	HD Tilt Equipped	17.3" STFH	16"-17", Do not go beyond 18" max seat depth
		17.8" STFH	16"-17", Do not go beyond 19" max seat depth
		All other STFH	16"-17", 19"-20" *20"-21"
	Tilt-Lift Equipped	All STFH	*16"-17" 18"-19", 20"-21"

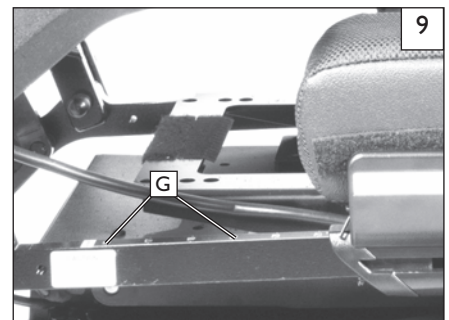

I. SEAT-TO-FLOOR HEIGHT 10

WARNING

Seat to floor height adjustments are uncommon and require expert knowledge of the original seat depth and details of the seating system. If it has been determined that a change needs to be made, Contact: Sunrise Medical, Customer Service Department at (800) 333-4000. Do not adjust the seat-to-floor height on this unit without referencing the seat-to-floor height matrix. It provides the possible seat-to-floor heights that are attainable based on seat frame and power module type available with the Sedeo Ergo seating system. Seat-to-floor height must be measured with batteries and no user. Ultra low Seat-to-floor height may cause ground clearance issues if it causes the centermount footrest to drop below 2" at its highest setting.

SEAT TO FLOOR HEIGHT ADJUSTMENT MATRIX	SEATING TYPE & POWER OPTION COMBINATIONS	SEAT TO FLOOR HEIGHT AT 0° TILT				
		0	+5"	+1"	+2"	+3"
Ultra-Low Seat to Floor Height Seat Frame "A" Reduces Seat to Floor Height by 1" from standard	MPC Power Recline and Tilt.		16.5"	17"	18"	19"
	MPC Power Recline and HD Tilt.		16.8"	17.3"	18.3"	19.3"
	MPC Power Recline with Tilt and 12" Lift combo	16.4"	16.9"	17.4"	18.4"	19.4"
Standard Seat to Floor Height Seat Frame "B" Seat pan is in line with recline pivot for Standard Seat to Floor Height	MPC Power Recline and Tilt.		*17.5"	18"	19"	
	MPC Power Recline and HD Tilt.		*17.8"	18.3"	19.3"	
	MPC Power Recline with Tilt and 12" Lift combo	17.4"	17.9"	18.4"	19.4"	

*Seat depth limited to 19" with the Seat to Floor Height (STFH) configuration
STFH measured with batteries but no user. Actual STFH may vary by .5"

J. LEG RESTS AND FOOTPLATES (POWER CENTER MOUNT) 10

1. Calfpad height, depth, and angle adjustment

- Using a 5mm hex key, loosen both screws(B) and move the calfpad(A) to the desired support distance.
- Adjust both sides equally in most cases.
- Re-tighten the hardware.

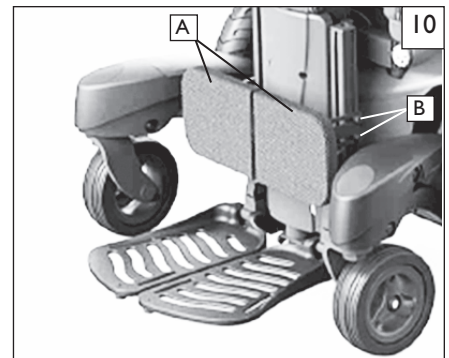

2. Footplate Height Adjustment 11

- Using a 5mm hex key, loosen the screws (C) holding the upper footplate mounting bracket,
- Move the footplates (D) up or down to set the correct height.
- Re-tighten the hardware to hold the adjustment in place.

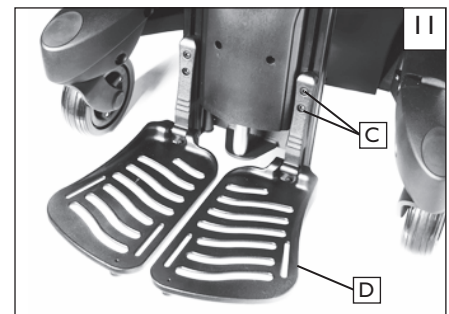

3. Footplate Angle Adjustment 12

- Using a 4mm hex key, rotate the screws (E) in or out to adjust the footplate(D) angle.
- Adjust up or down to refine the angle.

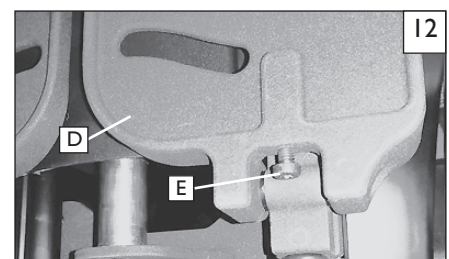

NOTE - After adjustment, the lowest point of the footplate should be at least 2" above the riding surface in order to avoid obstacles that would put the chair at risk of damage or tipping forward.

K. HEADREST HEIGHT, ANGLE AND DEPTH ADJUSTMENT 13

1 Headrest height, depth, and angle adjustment

- Using a 5mm hex key, and 13mm wrench, loosen the hardware(A) and move the headrest forward or backward and up or down to the desired support area
- Some angle adjustment is also possible by loosening the adjustment screw(B) and moving the headrest(C) to the preferred adjustment.
- Re-tighten the hardware.

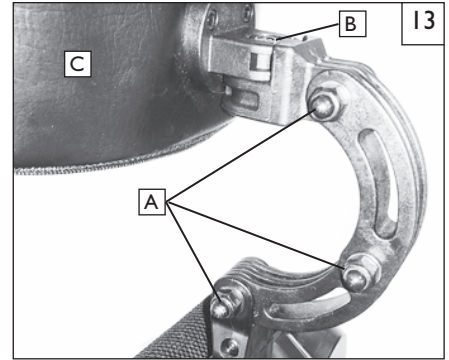

L. HEADREST OFFSET ADJUSTMENT 14

The headrest mount can be offset 2 inches to the left or right of center.

- Loosen the 4 screws (D) and move the headrest to the desired position.

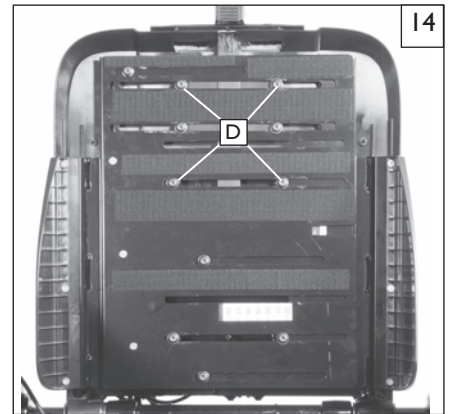

M. RETRACTABLE JOYSTICK MOUNT 15

The Retractable Joystick Mount attaches to the track on the inside of the armrest, and can swing in/out in increments of 45°, 90°, and 135°

1. Height adjustment

- Loosen the shaft locking screws(A) on the Joystick mount(B), and/or the Armrest mount(C).
- Adjust either mount up or down to the desired height.
- Retighten the Shaft locking screws(A)

2. Depth adjustment

- Using an 8mm open end wrench, loosen the hardware(D) on the Armrest mount(C) so that the channel nuts can slide freely within the track.
- Adjust mount either forward or back to the desired depth.
- Retighten the hardware(D)

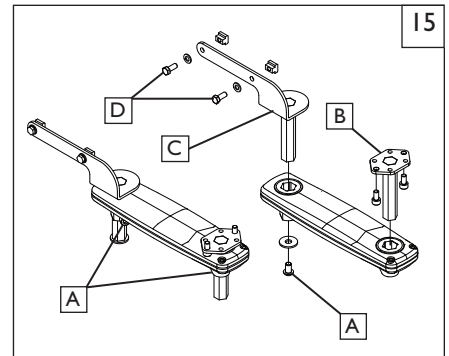

N. MIDLINE JOYSTICK MOUNT 16

The Midline Joystick Mount has 3 axis adjustment, and can be rotated out of the way.

1. Left, Right, Center adjustment

- Loosen the clamp screws (E) and move the joystick laterally in front of the rider.
- After finding the most comfortable adjustment, make sure the Joystick is level.
- Retighten the clamp screws.

2. Height adjustment

- Loosen the clamp screw (F) and move the joystick vertically,
- After finding the most comfortable adjustment, retighten the clamp screw.

3. Rotate Joystick out of the way.

- Loosen the clamp handle (G).
- Rotate the Joystick out of the way.
- Tighten the clamp handle until the Joystick can be returned to the driving position.

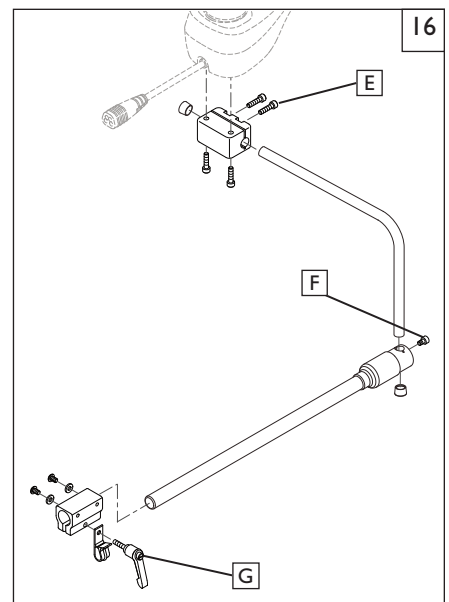

O. FRONT LIGHTING ADJUSTMENT 17

WARNING

Incorrect lighting adjustments that go beyond the ability of the user's vision range can result in serious injury. The front lighting assembly can be adjusted laterally or vertically to the user's needs. Any adjustment will have a better result if it is carried out in a dark room or garage. The user should also be in the chair to verify that the angles and placement for lighting are correct for their height and abilities.

1. Left, Right adjustment

- Using a 3mm hex key, loosen the screw (A) and move the lighting unit laterally, centering the beam in front of the rider at the preferred distance.
- Use the same procedure for the other side of the chair.
- Retighten the screws.

2. Vertical adjustment

- Loosen the set screws (B) on both sides of the chair and move the lighting units vertically, so that the surface in front of the chair is well lit at the correct distance for the user.

NOTE - The measured distance in front of the chair where the beams light up the riding surface will depend on average speed, and the height of the user.

- Tighten the set screws so that the lighting unit won't move when bumped, or vibrate loose.
- Make sure the adjustment is correct by allowing the user to drive with the new setting. Make any additional adjustments that are necessary.

P. PERFORMANCE CONTROL SETTINGS

NOTE— **BEFORE attempting to check and/or adjust settings on your joystick, be sure to see your Dealer or Clinician and have them make the adjustments if needed.**

- It is vital to match control settings to your level of function and ability.
- Consult your health care professional and your Authorized Dealer to select the best control settings for you.
- Check and adjust the settings every six to twelve months.

WARNING

Adjust the control settings immediately if you notice any change in your ability to:

- Control the joystick.
- Avoid running into objects.

Q. CTRL+5 ASSIGNABLE BUTTONS

The Ctrl+5 (Canbus switch) is a device that plugs into the PG Drives R-net system and allows for the set up of up to ten different functions into the ten discrete buttons, (each toggle switch is two buttons). This device uses the Sunrise Medical patented Assignable Buttons feature. The Ctrl+5 switches are pre-programmed from the factory to default values for the actuators on the chairs. Using the Dealer PC Programmer and dongle, the button assignments can be changed to any of the Assignable Buttons functions to suit the user just like the joystick buttons.

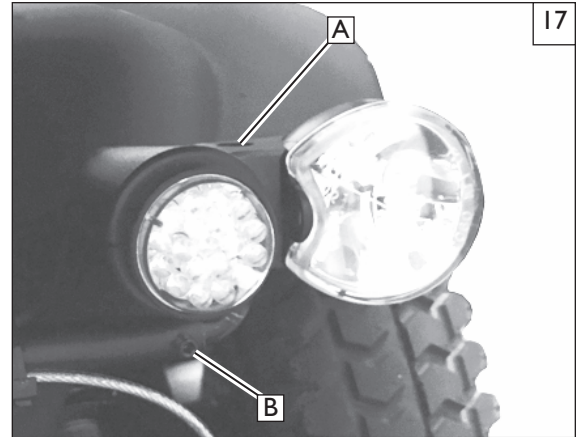

R. ON BOARD PROGRAMMER OR DTT (DIAGNOSTIC TEST TOOL) OR RNET PC PROGRAMMER (Optional)

WARNING

Program settings beyond the ability of the user can result in serious injury. Consult your health care advisor before you alter settings.

The On-board Programmer or RNET PC Programmer lets you adjust the control settings of the QM-710. Listed below are a few of the many settings that can be adjust via the On-board Programmer or RNET PC Programmer. (See RNET OBP Owners Manual for full programmable parameters.)

- acceleration rate
- deceleration rate
- turn acceleration
- turn deceleration
- forward speed (max & min)
- reverse speed (max & min)
- turn speed (max & min)
- steer correct

Programming the System:

- Access via DTT (Diagnostic Test Tool), or the PC Programmer require an inline connection to the communication cable.
- Program as needed.
- Remove Dongle or recycle power.

NOTE - Review the RNET OBP Owner's Manual for more details on how to program your system.

A. FOR FIVE (5) YEARS

Sunrise warrants the frame of this wheelchair against defects in materials and workmanship for five years from date of first consumer purchase.

B. FOR ONE (1) YEAR

We warrant all Sunrise-made parts and components of this wheelchair including: motors, gearboxes, and electronic components, against defects in materials and workmanship for one year from the date of first consumer purchase.

C. FOR SIX MONTHS

We warrant batteries for 6 months from the date of first consumer purchase.

D. LIMITATIONS

1. We do not warrant:
 - a. Tires and tubes, upholstery, pads and push-handle grips.
 - b. Damage from neglect, accident, misuse, or from improper installation or repair.
 - c. Products modified without Sunrise Medicals express written consent.
 - d. Damage from exceeding the weight limit.
2. This warranty is VOID if the original system serial number tag is removed or altered.
3. This warranty applies in the USA and Canada only. Check with your authorized dealer to find out if international warranties apply.
4. This warranty is not transferable and only applies to the first consumer purchase of this wheelchair through an authorized Sunrise Medical dealer.

E. WHAT WE WILL DO

Our sole liability is to repair or replace covered parts. This is the exclusive remedy for consequential damages.

F. WHAT YOU MUST DO

1. Obtain from an authorized supplier, while this warranty is in effect, prior approval for return or repair of covered parts.
2. Return the wheelchair or part(s), freight pre-paid, to Sunrise Mobility Products Division at: 2842 Business Park Avenue, Fresno, CA 93727-1328.
3. Pay the cost of labor to repair, remove or install parts.

G. NOTICE TO CONSUMER

1. If allowed by law, this warranty is in place of any other warranty (written or oral, express or implied, including a warranty of merchantability, or fitness for a particular purpose).
2. This warranty gives you certain legal rights. You may also have other rights that vary from state to state.

H. ADDITIONAL WARRANTY INFORMATION

For goods provided by Sunrise Medical Pty Ltd in Australia, our goods come with a guarantee by Sunrise that cannot be excluded under the Australian Consumer Law. You are entitled to a replacement or refund for a major failure and for compensation for any other reasonably foreseeable loss or damage. You are also entitled to have the goods repaired or replaced if the goods fail to be of acceptable quality and the failure does not amount to a major failure. The benefits to you given by this warranty are in addition to your other rights and remedies under a law in relation to the goods to which the warranty relates.

Record your serial number here for future reference:

Sunrise Medical • 2842 Business Park Ave. • Fresno, CA 93727 • USA
In Canada (800) 263-3390



Customer Service: 800.333.4000
www.SunriseMedical.com

©2016 Sunrise Medical (US) LLC
7.16 MK-100311 Rev.C