



QUICKIE XTENDER

## Quickie® XTENDER

**Supplier:** This manual must be given to the rider of this wheelchair.

Owner's Manual

**Rider:** Before using this wheelchair read this entire manual and save for future reference.

## Quickie® XTENDER

**Distribuidor:** Este manual debe ser entregado al pasajero de esta silla de ruedas.

**Pasajero:** Antes de usar esta silla de ruedas, lea este manual en su totalidad y guárdelo para futura referencia.

Manual de Instrucciones

Cada una de las sillas se envía con un manual de instrucciones en inglés. El manual en español o francés está disponible en formato PDF en nuestra página en Internet: [www.SunriseMedical.com](http://www.SunriseMedical.com). Ingrese a la página del producto específico para descargar el manual, o comuníquese con el proveedor autorizado de Sunrise Medical.

## Quickie® XTENDER

**Au Fournisseur:** Ce manuel doit être remis à l'utilisateur de ce fauteuil roulant.

**À l'Usager :** Veuillez lire tout le manuel et le conserver pour référence ultérieure.

Manuel d'instructions

Chaque fauteuil est livré avec un manuel d'instructions en anglais. Les versions en espagnol et en français sont à votre disposition en format PDF sur le site : [www.SunriseMedical.com](http://www.SunriseMedical.com). Veuillez vous rendre à la page de votre produit pour télécharger le manuel dans la langue souhaitée, ou contactez un fournisseur agréé Sunrise Medical.





<b>I. INTRODUCTION .....</b>	<b>2</b>	<b>VIII. USE AND MAINTENANCE .....</b>	<b>11</b>
<b>II. TABLE OF CONTENTS .....</b>	<b>3</b>	A. Introduction .....	11
<b>III. YOUR UNIT AND ITS PARTS .....</b>	<b>4</b>	B. Important Safety Checks.....	11
<b>IV. NOTICE-READ BEFORE USE.....</b>	<b>5</b>	C. Cleaning .....	11
A. Choose the Right Device .....	5	D. Safety Checklist .....	11
B. Review This Manual Often .....	5	E. Troubleshooting Chart.....	11
C. Warnings.....	5	F. To Mount & Remove the Xtender Wheels.....	12
<b>V. EMI (ELECTROMAGNETIC INTERFERENCE).....</b>	<b>5</b>	G. Storage tips .....	12
A. What is EMI? .....	5	H. Inspect .....	12
B. What effect can EMI have? .....	5	<b>IX. DEALER SERVICE &amp; ADJUSTMENT .....</b>	<b>13</b>
C. Sources of EMI .....	5	A. Dealer Service Introduction.....	13
D. Distance from the Source .....	6	B. Important Maintenance Tips.....	13
E. Immunity level .....	6	C. Cleaning.....	13
F. Report all Suspected EMI Incidents .....	6	D. Inspect.....	13
G. EMI from Chair .....	6	<b>X. SUNRISE LIMITED WARRANTY .....</b>	<b>15</b>
<b>VI. GENERAL WARNINGS.....</b>	<b>6</b>		
A. Weight Limits .....	6		
B. Intended use .....	6		
C. Attendants and Caregivers.....	6		
D. Accessories .....	6		
E. Know your device .....	6		
F. Reduce the risk of an Accident.....	7		
G. Safety Checklist.....	7		
H. Changes and adjustments .....	7		
I. Environmental Conditions.....	7		
J. Center of Balance.....	7		
K. Power On/off.....	7		
L. Moving Backward.....	7		
M. Transit .....	7		
N. Anti-tip tubes .....	8		
O. Fasteners .....	8		
P. Pneumatic Tires .....	8		
Q. Quick-release Axles .....	8		
R. Carrying or Moving the unit.....	8		
<b>VII. BATTERY AND CHARGER .....</b>	<b>9</b>		
A. Introduction .....	9		
B. Battery Types .....	9		
C. Charging .....	9		
D. Battery Storage .....	9		
E. Low Battery Levels .....	9		
F. Battery Safety.....	9		
G. Lithium Ion Battery .....	10		
H. Checking the Battery.....	10		
I. Charger safety .....	10		



1. Power Switch
2. Xtender power drive
3. Quick-release handle
4. Battery pack
5. Connector (Battery to Power drive)
6. High capacity battery
7. Battery removal button
8. Protective battery cover
9. 110V Power cord for charger
10. Charging unit
11. Xtender wheel
12. Hardware (not shown)

**NOTE:** All features may not be available with some chair setups or in conjunction with another chair feature. Please consult your authorized dealer for information.

**NOTE -** The Quickie Xtender is designed to fit on a variety of Quickie wheelchairs. Each chair has a different axle plate system that is designed to accept the Quickie Xtender quick-release wheels. For information concerning a specific chair, or axle plate system, please contact Sunrise Medical customer service, or consult the owner's manual for that chair.

### QUICKIE XTENDER SPECIFICATIONS

**Unit Weigh**

Approximately 18.5Kg (Ni) or 19.2kg (Li)

**Adjustments**

Front seat height must be greater than the rear.

**Tiresize**

Std- 22" and 24"

**Color**

Competition Silver

**Power Assist Unit**

Model Type - Direct current Brush-type motor  
 Rated Voltage - 24V  
 Rated Output -90 Wx2 (Left Wheel x 1, and Right Wheel x 1)

**Travel distance after a single charge**

Approximately 15Km (9.3 miles)  
 (For continuous travel on a level surface at 5km/h)

**Handrims**

Std- Plastic coated or Stainless Steel

**Range of assisted speeds**

0-6 Km/h

**Control**

Microcomputer control

**Drive**

Belt + Gear type (rear wheel direct drive)

**Steering**

Right and left hand-rim steering

**Braking**

Brake assist + manual wheelchair brake

**Battery**

Model type - Nickel-Hydrogen battery (Fast charging type)  
 Nominal Voltage - Two 1.2 Volt x 20-cell batteries connected in series, 24V  
 Nominal Capacity - 6.7 Ah (5-hour ratio)  
 Weight - 2.9Kg (6.4lbs)

**Charger**

Model type - JWC-2  
 Input Voltage - AC 100 ~240V, multi-input  
 Input frequency - 50/60 Hz  
 Charging current - Fast 2.6 A trickle 100mA  
 Cooling Method - Forced air cool  
 Range of Temperature at start of Charging - 0 to 40°C (Battery Temp)

Charging time - 2.5 to 3.0H

**Over current Interception**

30A blade-type micro fuse

## A. CHOOSE THE RIGHT DEVICE

This product is intended for single person use only. Final selection of the type of wheelchair, options and adjustments that are used with the Power Assist Technology rests solely with you and your health care professional. Choosing the best chair for your unique mobility needs, will depend on such things as:

1. Your disability, grasping strength, balance and coordination.
2. The types of hazards you must overcome in daily use (where you live and work, and other places you are likely to use your chair).

**INTENDED USE:** The Quickie Xtender is a battery operated device with wheels. It is intended to provide mobility and power assist to persons restricted to a sitting position.

## B. REVIEW THIS MANUAL OFTEN

Before using this device you, and each person who may assist you, should read this entire manual and make sure to follow all instructions. Review the warnings often, until they are second nature to you.

## C. WARNINGS

The word “WARNING” refers to a hazard or unsafe practice that may cause severe injury or death to you or to other persons. The “Warnings” are in three main sections, as follows:

### 1. V - EMI

Here you will learn about electromagnetic interference and how it can affect your chair.

### 2. VI. - GENERAL WARNINGS

Here you will find a safety checklist and a summary of risks you need to be aware of before you ride this chair.

### 3. VII. - SAFETY WARNINGS: BATTERIES

Here you will learn about practices for the safe use of your equipment, and how to avoid a fall or tip-over while you perform daily activities in your chair.

### 4. VIII. - BATTERIES

Here you will learn about battery and charger safety, and how to avoid injury.

Throughout this owner’s manual and on the wheelchair you will see the icons listed below to identify warnings and potential hazards.



**ESD:** Electrostatic Discharge can damage printed circuit boards.

**NOTE** – Where they apply, you will also find “Warnings” in other sections of this manual. Heed all warnings in these sections. If you fail to do so a fall, tip-over or loss of control may occur and cause severe injury to the rider or others.

## V. EMI (ELECTROMAGNETIC INTERFERENCE)

### WARNING

Heed all warnings to reduce the risk of unintended brake release or chair movement:

1. Beware of the danger from hand-held transceivers. Never turn on or use a hand-held transceiver while power to your device is on. Use extra care if you believe that such a device may be in use near your chair.
2. Be aware of nearby radio or TV stations, and avoid coming close to them.
3. If unintended movement occurs, turn your device off as soon as it is safe to do so.

## A. WHAT IS EMI?

### WARNING

1. EMI means: electromagnetic (EM) interference (I). EMI comes from radio wave sources such as radio transmitters and transceivers. (A “transceiver” is a device that both sends and receives radio wave signals).
2. There are a number of sources of intense EMI in your daily environment. Some of these are obvious and easy to avoid. Others are not, and you may not be able to avoid them.
3. Powered wheelchairs may be susceptible to electromagnetic interference (EMI) emitted from sources such as radio stations, TV stations, amateur radio (HAM) transmitters, two way radios, and cellular phones.
4. EMI can also be produced by conducted sources or electrostatic discharge (ESD).

## B. WHAT EFFECT CAN EMI HAVE?

### WARNING

1. EMI can cause your chair, without warning, to:
  - Release its brakes
  - Move by itself
  - Move in unintended directions
 If any of these occur, it could result in severe injury to you or others.
2. EMI can damage the control system of your chair. This could create a safety hazard, and lead to costly repairs.

## C. SOURCES OF EMI

### WARNING

The sources of EMI fall into three broad types:

### 1. Hand-Held Transceivers:

The antenna is usually mounted directly on the unit. These include:

- Citizens band (CB) radios
- “Walkie-talkies”
- Security, fire and police radios
- Mobile phones
- Lap-top computers with phone or fax
- Other personal communication devices
- Electronic article surveillance systems

**NOTE** – These devices can transmit signals while they are on, even if not in use.

### 2. Medium-Range Mobile Transceivers:

These include two-way radios used in police cars, fire trucks, ambulances and taxi cabs. The antenna is usually mounted on the outside of the vehicle.

**3. Long-Range Transceivers:**

These include commercial radio and TV broadcast antenna towers and amateur (HAM) radios.

**NOTE** - The following are not likely to cause EMI problems: Lap-top computers (without phone or fax), Cordless phones, TV sets or AM/FM radios, CD or tape players.

**D. DISTANCE FROM THE SOURCE****⚠ WARNING**

Electro-magnetic energy rapidly becomes more intense as you get closer to the source. For this reason, EMI from hand-held devices is of special concern. A person using one of these devices can bring high levels of EM energy very close to your chair without you knowing it.

**E. IMMUNITY LEVEL****⚠ WARNING**

1. The level of EM is measured in volts per meter (V/m). Every power assist device can resist EMI up to a certain level. This is called its "immunity level".
2. The higher the immunity level, the less the risk of EMI. It is believed that a 20 V/m immunity level will protect the power assist user from the more common sources of radio waves.
3. The common configuration tested and found to be immune to at least 20 V/m is: Quickie Xtender mounted to a Quickie 2 wheelchair using nickel hydride batteries.

**⚠ WARNING**

If there is any doubt that the specialty control input device is not immune to 20V/m, extra care should be taken around known sources of EMI.

**⚠ WARNING**

There is no way to know the effect on EMI if you add accessories or modify this chair. Any change to your chair may increase the risk of EMI. Parts not specifically tested or parts from other suppliers have unknown EMI properties.

**F. REPORT ALL SUSPECTED EMI INCIDENTS****⚠ WARNING**

You should promptly report any unintended movement or brake release. Be sure to indicate whether there was a radio wave source near your chair at the time. Contact:

Sunrise Medical, Customer Service Department at (800) 333-4000.

**G. EMI FROM CHAIR****⚠ WARNING**

The chair itself can disturb the performance of electromagnetic fields such as emitted by alarm systems of shops.

## VI. GENERAL WARNINGS

**A. WEIGHT LIMITS****⚠ WARNING**

NEVER exceed the weight limit specified by Sunrise Medical. The weight capacity provided by your manufacturer is for the combined weight of a rider and items carried using on-board storage. If you do exceed the weight limit, damage to your chair, a fall, tip-over or loss of control may occur and cause severe injury to the rider or others.

The maximum weight capacity for the Xtender is 265 lbs (120 kg).

**⚠ WARNING**

If the maximum weight limit for your chair is lower than 265 lbs (120 kg), do not exceed the stated weight limit for your chair.

**B. INTENDED USE**

The wheelchairs on which the Xtender has been installed, empower physically challenged persons by providing a means of enhanced mobility. This owner's manual refers to the power-assist accessory only. For warnings and information about the correct use and care of your specific wheelchair, please refer to the owner's manual provided with that specific chair.

**⚠ WARNING**

DO NOT use this device for purposes other than what is intended by the manufacturer. Unauthorized modifications and use of parts or accessories not supplied or approved by Sunrise Medical may change the chair structure. This will void the warranty and may cause a safety hazard. If the warning is ignored, damage to your chair, and the potential for severe injury of the person using the chair for unintended purposes can occur.

**C. ATTENDANTS AND CAREGIVERS****⚠ WARNING**

Before you assist a rider, be sure to read all warnings contained in this manual, and follow all instructions that apply. Be aware that after consulting a healthcare professional, you will need to learn safe and proven body mechanics to use and create assistive methods best suited to your abilities.

**D. ACCESSORIES****⚠ WARNING**

Unauthorized modifications or use of parts, or accessories not supplied or approved by Sunrise Medical may change the chair structure. This will void the warranty and may cause a safety hazard.

Some problems that may occur, but are not limited to:

1. Incorrect wheels and/or tires that put the rider at risk of a fall or tip-over.
2. Any modification or disassembly can potentially create an unsafe situation where rider and/or attendant are put at risk.

**E. KNOW YOUR DEVICE****⚠ WARNING**

Take the time to learn the feel of this device before you begin riding. Start slowly, with easy, smooth strokes. If you are used to a different chair, you may use too much force and tip over. If you use too much force, damage to your chair, a fall, tip-over or loss of control may occur and cause severe injury to the rider or others.

## F. REDUCE THE RISK OF AN ACCIDENT

### ⚠️ WARNING

1. BEFORE you begin riding, you should be trained in the safe use of this device by your health care advisor.
2. Be aware that you must develop your own methods for safe use best suited to your level of function and ability.
3. NEVER try a new maneuver on your own. Ask the advice of your health care professional to lower the risk of a fall or tip over.
4. Get to know the areas where you plan to use your device. Look for hazards and learn how to avoid them.

## G. SAFETY CHECKLIST

### ⚠️ WARNING

#### Before Each Use Of Your Device:

1. Make sure the chair rolls easily and that all parts work smoothly. Check for noise, vibration, or a change in ease of use. (This may indicate low tire pressure, loose fasteners, or damage to your chair).
2. Inspect for any problems. Your authorized dealer can help you find and correct the problem(s).
3. Check to see that both quick-release rear axles are locked. When locked, the axle button will "pop out" fully. If not locked, the wheel may come off and cause you to fall.
4. If your chair has anti-tip tubes, lock them in place.

## H. CHANGES & ADJUSTMENTS

### ⚠️ WARNING

1. See your healthcare professional and have them re-assess the basic fit and performance measurements, and adjust seating components when the Quickie Xtender is added to an existing chair.
2. Unauthorized modifications or use of parts not supplied or approved by Sunrise may change the chair structure. This will void the warranty and may cause a safety hazard.

If you fail to heed these warnings, damage to your chair, a fall, tip-over or loss of control may occur and cause severe injury to the rider or others.

## I. ENVIRONMENTAL CONDITIONS



### ⚠️ WARNING

1. Use extra care if you must expose the Quickie Xtender to wet or cold conditions.
2. Contact with water or excess moisture may cause your chair to rust or corrode. Electronic components may also be effected. Avoid all extreme weather situations if possible.
  - a. Do not use your device in a shower, pool or other body of water, or use a sprayer to wash it. The parts are not watertight and may rust or corrode from the inside.
  - b. Avoid excess moisture (for example, do not leave the unit in a damp bathroom while taking a shower).
  - c. Dry your device as soon as you can if it gets wet, or if you use water to clean it.

If you fail to heed these warnings, damage to your chair, a fall, tip-over or loss of control may occur and cause severe injury to the rider or others.

## J. CENTER OF BALANCE

### ⚠️ WARNING

Adding the Quickie Xtender to an existing chair will effect the center of balance. The point where this chair will tip forward, back or to the side depends on its center of balance and stability. How your chair is set up, the options you select and the changes you make may affect the risk of a fall or tip-over.

1. The Center Of Balance Is Also Affected By:
  - a. A change in your body position, posture or weight distribution.
  - b. Riding your chair on a ramp or slope.
  - c. A back pack or other options and the amount of added weight.
2. To Reduce The Risk Of An Accident:
  - a. Consult your authorized dealer BEFORE you modify or adjust this device. Be aware that you may need to make other changes to correct the center of balance.
  - b. Have someone help you until you know the balance points of your chair and how to avoid a tip-over.
  - c. Use anti-tip tubes.

If you fail to heed these warnings, you are at a high risk of a fall, tip-over or loss of control that could cause severe injury to the rider or others.

## K. POWER ON/OFF

### ⚠️ WARNING

Do not remove the battery while the power assist is in operation, this will cause the brakes to be applied to the chair and cause an unsafe situation.

Turn off the power switch and apply the brake in crowded or unpredictable situations where someone might bump or push one of the wheelchair rims, causing the wheelchair to move unexpectedly.

Do not apply the ON/OFF button while on a slope.

1. Before applying the ON/OFF button:
  - a. Park in a level area.
  - b. Apply the parking brake.

## L. MOVING BACKWARD

### ⚠️ WARNING

Use extra care when you move your chair backward. Your chair is most stable when you propel yourself forward. You may lose control or tip over if one of the rear wheels hits an object and stops rolling.

1. Propel your chair slowly and smoothly.
2. If your chair has anti-tip tubes, make sure to lock them in place.
3. Stop often and check to be sure your path is clear.

If you fail to heed this warning, you are at a high risk of damage to your chair, a fall, tip-over or loss of control that may occur and cause severe injury to the rider or others.

## M. TRANSIT

### ⚠️ WARNING

The transit option is not available with Xtender Power assist.

1. The Transit option should not be added to any wheelchair with the Xtender.
2. ALWAYS remove the rider from the chair and use original equipment manufacturer (OEM) vehicle restraints when transport is necessary.

If you fail to heed this warning, you are at a high risk of damage to your chair, a fall, tip-over or loss of control that may occur and cause severe injury to the rider or others.

## N. ANTI-TIPTUBES

 **WARNING**

Anti-tip tubes can help keep your chair from tipping over backward in normal conditions. If your chair includes anti-tip tubes be sure to re-adjust them after adding the Xtender to the chair.

1. Sunrise recommends the use of anti-tip tubes.
2. When locked in place (in the “down” position) anti-tip tubes should be BETWEEN 1-1/2 to 2 inches (38 to 51mm) off the ground.
  - a. If set **higher** than 2 inches (51mm), they may not prevent a tip-over.
  - b. If set **lower** than 1-1/2 inches, (38 mm) they may “hang up” on obstacles and cause a fall or tip over.

If you fail to heed these warnings damage to your chair, a fall, tip-over or loss of control may occur and cause severe injury to the rider or others.

## O. FASTENERS

 **WARNING**

Many of the screws, bolts and nuts on this chair are special high-strength fasteners. Use of improper fasteners may cause your chair to fail.

1. **ONLY** use fasteners provided by an authorized dealer (or ones of the same type and strength, as indicated by the markings on the heads).
2. Over- or under-tightened fasteners may fail or cause damage to chair parts.
3. If bolts or screws become loose, tighten them as soon as you can.

NOTE- For safety and optimum performance it is best to not reuse fasteners.

## P. PNEUMATIC TIRES

 **WARNING**

Proper inflation extends the life of your tires and makes your chair easier to use.

1. Do not use this chair if any of the tires are under- or over-inflated. Check weekly for proper inflation level, as listed on the tire side-wall.
2. Low pressure in a rear tire may cause the wheel lock on that side to slip and allow the wheel to turn when you do not expect it.
3. Low pressure in any of the tires may cause the chair to veer to one side and result in a loss of control.
4. Over-inflated tires may burst.

If you fail to heed these warnings damage to your chair, a fall, tip-over or loss of control may occur and cause severe injury to the rider or others.

## Q. QUICK-RELEASE AXLES

 **WARNING**

1. Do not use this chair **UNLESS** you are sure that both quick-release rear axles are locked.
2. An axle is not locked until the quick-release button pops out fully.
3. An unlocked axle may come off during use, resulting in a fall, tip-over or loss of control and cause severe injury to the rider or others.
  - Quick-Release Axles should be periodically cleaned and inspected for function and signs of wear or bending. Replace as necessary.

If you fail to heed these warnings damage to your chair, a fall, tip-over or loss of control may occur and cause severe injury to the rider or others.

## R. CARRYING OR MOVING THE DEVICE

 **WARNING**

Do not lift the wheelchair by its handrims, the battery or the cable. This could cause damage, especially if the wheelchair and its passenger are lifted together, there is a risk of tipping over or falling out. Please observe the following:

- Engage the wheel locks on both wheels so that they cannot turn.
- Switch off the power supply.
- Lift the wheelchair only by the frame.



## A. INTRODUCTION

### 1. Battery Notes—

- Batteries supply the power for your chair. They contain a finite amount of energy and have limits on how long they can store and supply energy.
- You can charge batteries only a certain number of times before they will fail and no longer hold a charge.
- When storing or transporting your chair and device, ALWAYS remove the battery and replace the protective cover for storage.
- For answers to questions about batteries, consult your authorized dealer.

### 2. Use Proper Batteries:

Your chair operates on one battery.

- Use the battery supplied with the unit.
- When you buy a replacement, purchase the same kind of battery that was supplied with the unit.

### 3. Before removing the battery:

- Turn off the Power switch.
- Disconnect the battery by pulling it out of the cradle.

### IMPORTANT:

- DO NOT press the “REFRESH” button during the first 3 charging cycles. Ignoring this will prevent the Battery from reaching its full capacity.
- A battery requires “breaking-in” for the first 6 to 12 charges. It will not accept a full charge for this period.
- It is best to limit the length of your trips until you break the batteries in and you know the range of your chair.

## B. BATTERY TYPES

There are two types of batteries you can use for the Quickie Xtender system. Check the label on the battery to determine your specific type.

1. **Ni-MH or (Nickel Metal Hydride)** comes with its own charging system. Do not use a charger other than the one provided with your specific battery. Damage to the battery, and/or the charger unit can occur if using a charging unit other than what was provided by the manufacturer.
2. **Li-ion 00 (Lithium ion)** comes with its own charging system. Do not use a charger other than the one provided with your specific battery. Damage to the battery, and/or the charger unit can occur if using a charging unit other than what was provided by the manufacturer.

## C. CHARGING

### 1. Ni-MH charging notes

The battery can be charged in two ways:

1. **Refresh Charge** - Indicated by a yellow flashing light for 10 seconds.  
**Important** - (Only push the refresh button when indicated)
  - a. The refresh charge revitalizes the battery by fully discharging and then recharging the cells preventing a loss in capacity.
  - b. The refresh charge can take 9-12 hours to complete.
2. **Quick Charge** - Indicated by a solid green light.  
**Important** - If the light is flashing green, this means that the battery is either too hot (105°F) or too cold (+45°F). The light will continue to flash until the battery returns to the correct temperature range.
  - a. Place the battery in the charger station. When the battery is the correct temperature, the charger display illuminates green and charging begins. A quick charge can take 1-3 hours to complete.
  - b. The progress of charging is shown on the battery capacity display. This display serves as an indicator for the progress.
  - c. When charging is complete, the green charging light and the battery capacity display will shut off.

### 2. Li-ion 00 charging notes

This type of battery does not have a refresh charge.

1. Standard charge process - On-board or table top.

Important - Make sure the protective cap is on the battery when charging. Charge with the battery resting on its side. If charging from the backpack, make sure that the charge cord is not tangled.

- a. Insert the power cord in the charger and plug the other end into the power outlet. The charge light (green) should come on. Charging can take 3.5 hours to complete.
- b. The progress of charging is shown on the battery capacity display. This display serves as an indicator for the progress.
- c. When charging is complete, the green charging light and the battery capacity display will shut off.
- d. After charging has completed, unplug the charge plug and the power plug, then secure the battery's connector cover.

## D. BATTERY STORAGE

### WARNING

When storing a fully charged and disconnected battery, make sure to store it with the protective plastic cap. Exposed contacts on the bottom of the battery can cause short circuits and lead to a fire or battery rupture. Never store the battery in direct sunlight or outdoors.

## E. LOW BATTERY LEVELS

### WARNING

ALWAYS be aware of the battery life. Check it frequently. It is best to carry a spare battery when taking prolonged rides. When the battery warning light flashes and you hear the “pip-pip-pip-pip”, sound, change the battery promptly. If you continue to use the power assist function and the battery is completely discharged, the battery warning light will be constantly illuminated and you will hear a “beep” tone. The power assist function will switch off. You must change to a replacement battery.

1. First get your wheelchair to a safe place. Turn the power supply off and switch to the replacement battery. If you have no replacement battery with you, leave the power supply turned off while driving.
2. If you cannot change the battery on your own, an attendant must be present.

## F. BATTERY SAFETY

### WARNING

The battery on the Quickie Xtender is not very large but stores a large amount of charge. Improper use can cause damage or in certain circumstances lead to burns or fire.

- Only use battery for the intended purpose of power assist for a wheelchair.
- Keep the battery out of reach of children and anyone who is not familiar with it.
- When transporting the wheelchair, remove the battery from the wheelchair and apply the protective cap.
- When the battery is not in use, always use the protective cap.
- If the battery housing is damaged, a corrosive liquid (KOH) can be emitted. Avoid any contact with the skin and discontinue use, if you notice any damage to your unit.
- Do not allow battery connection clamps to come into contact with wires or metal.
- Do not expose the battery to impact; do not add or remove parts to the battery.
- Do not expose the battery to heat or place near fire or water.
- Do not use a broken or damaged battery.
- Do not disassembly or modify the battery.
- Do not charge or store the battery near pets or children.

## G. LITHIUM ION BATTERY

### I. Temperature

#### WARNING

- a) While travelling, if the internal temperature of the lithium ion battery becomes too high or too low, a buzzer will notify you.
- b) When the buzzer beeps, promptly return to the environment within the recommended range of operational temperatures, and use the battery in that environment.
- c) When descending down a slope on the wheelchair, the drive motor, contrary to normal operation, generates electricity and charges the battery. Charging a lithium ion battery in this way when its temperature is below 0°C or above 45°C will cause its deterioration. To protect the battery in these conditions, the wheelchair may stop itself.
- d) When this happens, you will hear 5 long beeps to warn of an eminent stop, and then another long beep 10 seconds later as the wheelchair comes to a stop.

### 2. Charging:

- a) The Lithium Ion battery comes with its own charging system.
- b) Do not use a charger other than the one provided with your specific battery. If you fail to heed this warning, damage to the battery, and/or the charger unit can occur.

## H. CHECKING THE BATTERY

The battery capacity and charging progress is shown when the display key is pressed. The total capacity is shown by LED indicator lights. Each light represents about 20% of the total capacity of the battery. The display is active for approximately 5 seconds.

### 1. Charge timing and battery life for Ni-MH battery:

- a) While traveling, check the display often.
- b) If the Power assist drive is only on for a short distance, get the chair to a safe location and change out the battery for a new one, or charge your battery immediately.
- c) If the Battery when fully charged is only at 60% capacity then it is time to replace the battery.

### 2. Battery malfunction display:

- a) The battery display will show if there is an internal malfunction.
- b) If the fourth LED flashes constantly please contact your authorized dealer.

### 3. Lithium Ion battery life:

- a) Battery life is approximately 8 years from the date of purchase. The alert will start about 3 months before the battery reaches the end of its life. The end of the battery is signaled by the capacity lights cycling on for 5 seconds each one at a time.
- b) When the battery can no longer be charged, the battery indicator lamp no longer lights.

## I. CHARGER SAFETY

#### WARNING

The charger for the Quickie Xtender is a very sensitive piece of equipment. Improper use can cause damage or in certain circumstances lead to burns or fire.

- When charging always use the charger supplied.
- The charging system has intake and exhaust vents that need to be open in order for the unit to function correctly. These areas should be free of obstructions.
- Always charge on a level surface. After use do not keep it plugged into the power outlet
- Keep the charging unit out of reach of children and anyone who is not familiar with it.
- Do not use a charger if it has a damaged cord, or if it has been dropped.

**⚠ WARNING**

The owner of this unit is responsible for making sure that it has been set up and adjusted by a trained service professional under the advice of a healthcare professional. The unit may require periodic safety and function checks or certain in-use adjustments that can be performed by the owner, caregiver or authorized dealer if desired. Always use parts and/or accessories that have been recommended or approved by Sunrise Medical when servicing this unit.

**A. INTRODUCTION**

1. Proper maintenance will improve performance and extend the useful life of this unit.
2. Clean your unit regularly. This will help you find loose or worn parts and make your chair easier to use. You will need a mild detergent solution and plenty of cleaning rags.
3. If discovered, have loose, worn, bent or damaged parts replaced before using unit.
4. To protect your investment, have all major maintenance and repair work done by your authorized dealer.
5. Inspect and maintain this unit strictly per the safety checklist.
6. If you detect a problem, make sure to order parts, or have service, and repair work done at your authorized dealer before use.
7. At least once per year, have a complete inspection, safety check, and service of your unit made by an authorized dealer.

**B. IMPORTANT SAFETY CHECKS**

1. **Tire Air Pressure:**  
Check air pressure in pneumatic tires at least ONCE PER WEEK. The wheel locks will not grip properly if you fail to maintain the air pressure shown on tire sidewall.
2. **Axles & Axle Sleeves:**  
When checking axles and axle sleeves every six months, make sure they are clean and tight. Loose sleeves will damage the axle plate and will affect performance.
3. **Camber Tubes and Camber Plugs**  
Inspect the camber tubes and plugs every 6 months ensuring that all fasteners are tight and that no parts have moved from their preset positions. See page 13 for torque specs.

**C. CLEANING**

1. **Paint Finish**
  - a. Clean the painted surfaces with mild soap or detergent at least once a month.
  - b. Protect the paint with a coat of non-abrasive auto wax every three months.
2. **Axles and Moving Parts**
  - a. Clean around axles and moving parts WEEKLY with a slightly damp (not wet) cloth.
  - b. Wipe off or blow away any fluff, dust or dirt on axles or moving parts.
3. **Battery Backpack**
  - a. Hand-wash (machine washing may damage fabric).
  - b. Drip-dry only. DO NOT machine dry as heat will damage fabric.
4. **Basic Maintenance Materials available at local store**
  - a. Tire pump
  - b. Tire pressure gauge
  - c. Clean rags or cotton cloth.
  - d. Mild detergent.

**NOTE** - You do not need to grease or oil the unit.

**D. SAFETY CHECKLIST**

Weekly	3 Months	6 Months	Annually	Safety & Function Check
<input checked="" type="checkbox"/>				Tire inflation level
<input checked="" type="checkbox"/>				Wheel locks
	<input checked="" type="checkbox"/>			Visually check for loose hardware
		<input checked="" type="checkbox"/>		Axle and axle sleeves
	<input checked="" type="checkbox"/>			Quick-release axles
	<input checked="" type="checkbox"/>			Wheels, tires, and spokes
	<input checked="" type="checkbox"/>			Anti-tip tubes
			<input checked="" type="checkbox"/>	<b>Service by authorized dealer</b>

**NOTE** - The user or caregiver should perform these weekly and monthly checks to maintain the safety of their chair. If an item is not working properly, please contact your authorized dealer.

**E. TROUBLESHOOTING CHART**

Symptom	Chair slowing down	Chair won't move	Shortage of power	Sluggish turning	Squeaks and rattles	Chair veers to side	Solution
							<input type="checkbox"/>
<input type="checkbox"/>	<input type="checkbox"/>	<input type="checkbox"/>	<input type="checkbox"/>	<input checked="" type="checkbox"/>	<input checked="" type="checkbox"/>	<input checked="" type="checkbox"/>	Make sure all spokes and nipples are tight on radial spoke wheels. Check battery, charge battery, reset the power on the unit.

**F. MOUNT AND REMOVE THE XTENDER WHEELS**

1 2 3 4

The rear wheel axle (B) attaches the rear wheel into the axle sleeve (C). When the detent balls (D) engage into the axle sleeve, the rear wheel effectively becomes locked onto the chair. Pulling up on the quick-release handle (A) disengages the detent balls and allows mounting, or removal of the axle and wheel assembly.

**⚠ WARNING**

Do not use this chair UNLESS you are sure both quick-release axles are locked and the guide pins are in the correct location. An unlocked axle/wheel may come off during use and cause a fall. The detent ball (D) must feed all the way through the axle sleeve for the axle and wheel to lock. Be sure to check for a positive lock by trying to pull the axle and wheel out of the camber plug/axle sleeve. If the axle does not positively engage make sure to have your dealer adjust it.

**NOTE**- Setup for this step should include putting the wheelchair on a workbench or table to make the process easier.

**1. Install the Xtender wheel**

- a. Lift the quick-release handle (A) fully.
- b. Insert axle (B) through axle sleeve (C).
- c. Line up the appropriate guide pin with the corresponding receiver hole on the axle plate assembly.
- d. Keep handle (A) lifted as you slide axle (B) into axle sleeve (C).
- e. Push the handle back to home position to lock axle onto the chair.
- f. Repeat these steps for the other side of your wheelchair.

**2. Power cord installation**

- a. Locate the Power/Battery cord (G) (Battery backpack).
- b. Insert and twist the plug end of the cord into the power receiver (F).
- c. Check to make sure the Plug and receiver are locked in place before travel.
- d. The Xtender should be ready for use.

**3. To Remove the Xtender Wheel**

- a. Remove and store the battery anytime the unit is being moved or stored.
- b. Lift the quick-release handle (A) fully.
- c. Remove wheel by sliding axle (B) out of axle sleeve (C).
- d. Repeat steps on the other side of your wheelchair.

**G. STORAGE TIPS**

1. ALWAYS remove the battery and replace the protective battery cover when storing or moving the unit. Optimal storage temperature is between 50°F and 77°F.
2. Store your unit in a clean, dry area. If you fail to do so, parts may rust or corrode.
3. Before using your unit, make sure it is in proper working order.
4. Inspect and service all items on the "Maintenance Chart".
5. If stored for more than three months, have your unit inspected by an authorized dealer before use.
6. When not in use the battery should be recharged every three months to ensure optimum performance after being stored.

**H. INSPECT**

After the installation of the Quickie Xtender, and the wheelchair is assembled and adjusted, it should roll smoothly and easily. All accessories should also perform smoothly. If you have any problems, follow these procedures:

1. Review the set-up and check-out sections and operating guide to make sure chair was properly prepared.
2. Review the troubleshooting chart at the beginning of this section.
3. If your problem persists, contact your authorized dealer. If you still have a problem after contacting your authorized dealer, contact Sunrise Medical customer service. See the Introduction page for details on how to contact your authorized dealer or Sunrise Medical customer service.

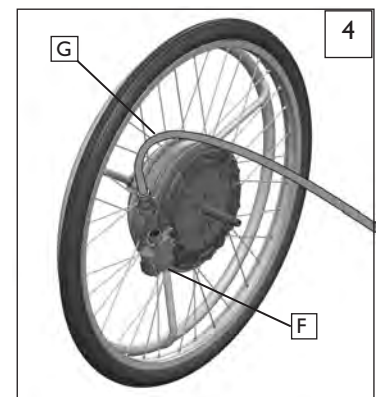
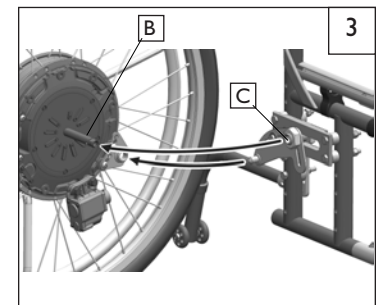
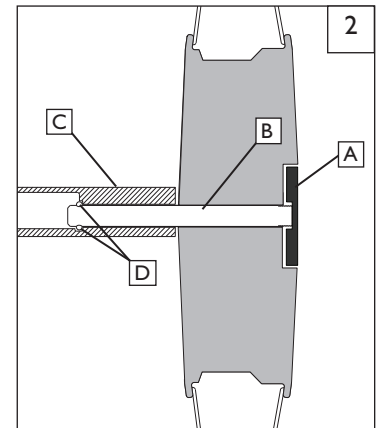
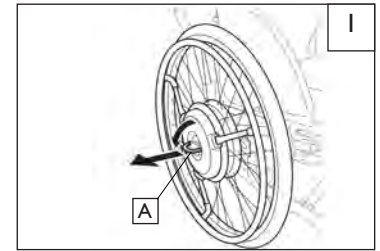

**⚠ WARNING**

The owner of this unit is responsible for making sure that it has been setup and adjusted by a trained service professional. Service and/or adjustments should only be done by a professional. Always use parts and/or accessories that have been recommended and approved by Sunrise Medical when servicing this unit.

**A. DEALER SERVICE INTRODUCTION**

1. At least once per year, this unit should have a complete inspection, safety check, and regular service made by an authorized dealer.
2. Torque settings— A torque setting is the optimum tightening which should be made on a particular fastener. It is important to use proper torque settings where specified. When not specified, torque settings should be 62 in-lbs.
3. If you have discovered a worn, bent, or damaged part, repair or replace them with recommended parts before returning this unit to service.
4. All major maintenance and repair work should be done by an authorized dealer.

**B. IMPORTANT MAINTENANCE TIPS****1. Torque settings:**

A torque setting is the optimum tightening which should be made on a particular fastener. It is important to use proper torque settings where specified. When not specified, torque settings should be 62 in-lbs.

**2. Dealer service and adjustment reference materials:**

For help with maintenance go to [www.sunrisemedical.com](http://www.sunrisemedical.com) for parts manuals, owner's manuals, and instruction sheets that will aid in the repair and maintenance of the Quickie Xtender.

You may also refer to the following documents:

- 1) Yamaha JWX-2 service manual
- 2) Your wheelchair owner's manual

**C. CLEANING****1. Paint Finish**

- a. Clean the painted surfaces with mild soap or detergent.
- b. Protect the paint with a coat of non-abrasive auto wax.

**2. Axles and Moving Parts**

- a. Clean around axles and moving parts with a slightly damp (not wet) cloth.
- b. Wipe off or blow away any fluff, dust or dirt on axles or moving parts.

**D. INSPECT****1. Final inspection instructions:**

After the unit is assembled and adjusted, it should roll smoothly and easily. All accessories should also perform smoothly. If you have any problems, follow these procedures:

1. Review the set-up and check-out sections and operating guide to make sure the unit was properly prepared, and installed correctly on your chair.
2. Review any troubleshooting information in this manual.
3. If you determine that a problem exists, contact your authorized dealer. If you still have a problem after contacting your authorized dealer, contact Sunrise customer service. See the Introduction Page for details on how to contact your authorized dealer or Sunrise customer service.



**A. FOR ONE (1) YEAR**

Power unit, charger, and components:

1. During this warranty period, if there is a material or manufacturing defect in the Xtender, the defective parts will be replaced or repaired. An invoice, as proof of purchase, may be required.
2. This warranty does not apply if:
  - a. The product is subject to abuse.
  - b. The product is not maintained as recommended in the owner's manual.
  - c. The product is transferred to a different person from the original owner.

**B. LIMITATIONS**

1. We do not warrant:
  - a. Consumable parts such as tires, tubes, and battery.
  - b. Damage from neglect, accident, misuse, or from improper installation or repair.
  - c. Products modified without Sunrise Medical's express written consent.
  - d. Damage from exceeding the weight limit.
2. This warranty is VOID if the original serial number tag is removed or altered.
3. This warranty applies in the USA and Canada only. Check with your authorized dealer to find out if international warranties apply.
4. This warranty is not transferable and only applies to the first consumer purchase of this product through an authorized Sunrise Medical dealer.

Record your serial number here for future reference:

---

**C. WHAT WE WILL DO**

Our sole liability is to repair or replace covered parts. This is the exclusive remedy for consequential damages.

**D. WHAT AUTHORIZED DEALER MUST DO**

1. Obtain from Sunrise Medical, while this warranty is in effect, prior approval for return or repair of covered parts. Contact Customer Service for a Returned Material Authorization (RMA) number and information as to where to return the product.

**E. NOTICE TO CONSUMER**

1. You must pay the cost of labor to repair, remove or install parts even if they are covered under warranty.
2. If allowed by law, this warranty is in place of any other warranty (written or oral, express or implied, including a warranty of merchantability, or fitness for a particular purpose).
3. This warranty gives you certain legal rights. You may also have other rights that vary from state to state or province to province.

**F. ADDITIONAL WARRANTY INFORMATION** For goods provided by Sunrise Medical Pty Ltd in Australia, our goods come with a guarantee by Sunrise that cannot be excluded under the Australian Consumer Law. You are entitled to a replacement or refund for a major failure and for compensation for any other reasonably foreseeable loss or damage. You are also entitled to have the goods repaired or replaced if the goods fail to be of acceptable quality and the failure does not amount to a major failure. The benefits to you given by this warranty are in addition to your other rights and remedies under a law in relation to the goods to which the warranty relates.

**Sunrise Medical • 2842 N. Business Park Ave. • Fresno, CA 93727 • USA**  
**In Canada (800) 263-3390**



Customer Service: 800.333.4000  
[www.SunriseMedical.com](http://www.SunriseMedical.com)

©2018 Sunrise Medical (US) LLC  
06.18 MK-100156 Rev.C